

SECTION 7: PARTS

Parts Breakdown and List

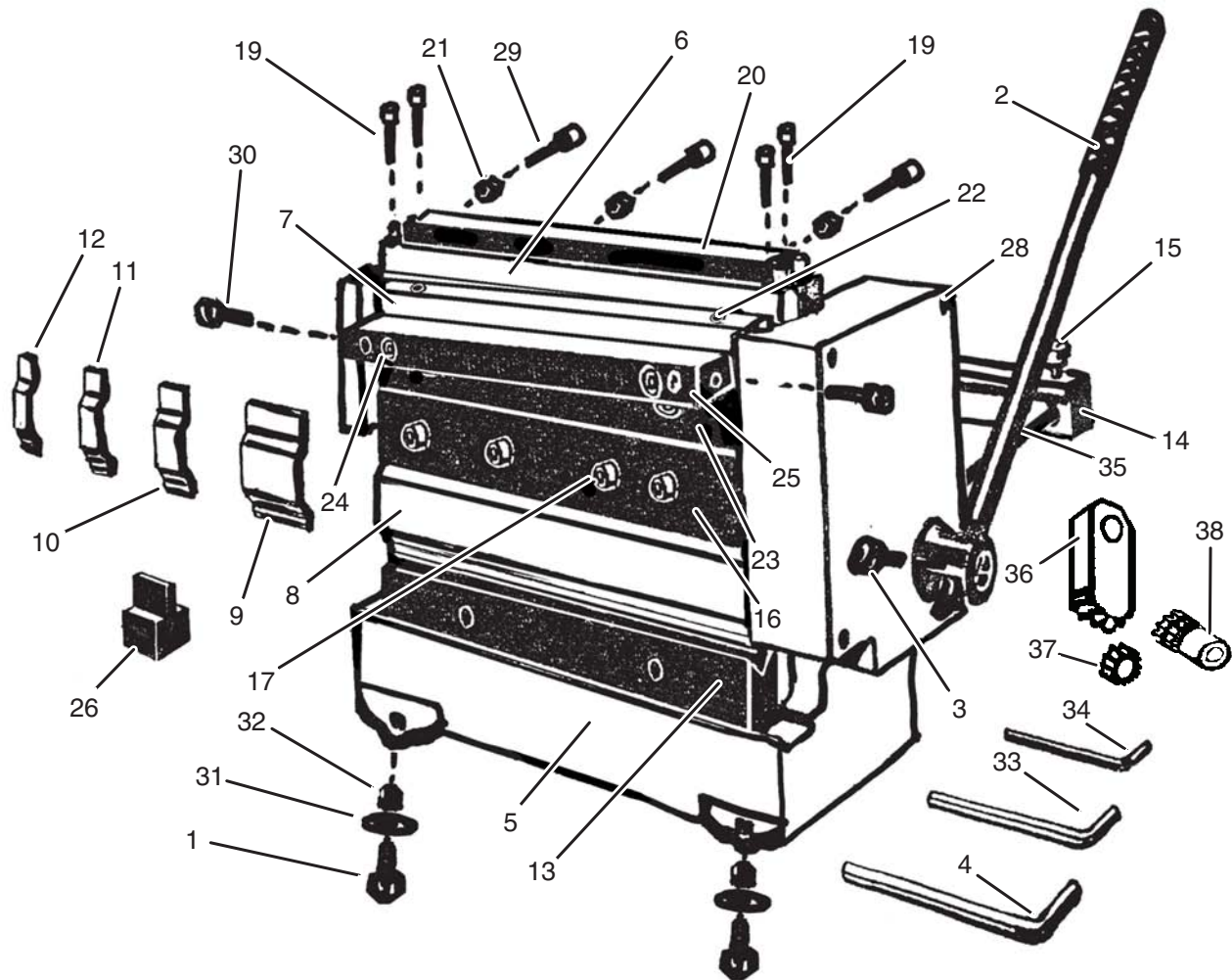

REF	PART #	DESCRIPTION
1	PB44M	HEX BOLT M10-1.5 X 75
2	P9950002	WORK LEVER
3	P9950003	KNURLED THUMB KNOB
4	PAW05M	HEX WRENCH 5MM
5	P9950005	MAIN CASTING
6	P9950006	FIXED KNIFE
7	P9950007	SHEARING KNIFE
8	P9950008	FINGER 8"
9	P9950009	FINGER 1-1/8"
10	P9950010	FINGER 13/16"
11	P9950011	FINGER 5/8"
12	P9950012	FINGER 7/16"
13	P9950013	FINGER RECEIVER
14	P9950014	STOP
15	P9950015	KNURLED THUMB KNOB
16	PSB33M	CAP SCREW M5-.8 X 12
17	PSB38M	CAP SCREW M5-.8 X 25
19	PSB15M	CAP SCREW M5-.8 X 20

REF	PART #	DESCRIPTION
20	P9950020	GIB BLOCK
21	PN04M	HEX NUT M4-.7
22	PSB17M	CAP SCREW M4-.7 X 10
23	P9950023	SLIDE
24	PSB10M	CAP SCREW M5-.8 X 15
25	P9950025	GIB
26	P9950026	SEATING BLOCK
28	PFH19M	FLAT HD SCR M4-.7 X 10
29	PSB162M	CAP SCREW M4-.7 X 25
30	PSB06M	CAP SCREW M6-1 X 25
31	PW04M	FLAT WASHER 10MM
32	PN03M	HEX NUT M8-1.25
33	PAW04M	HEX WRENCH 4MM
34	PAW03M	HEX WRENCH 3MM
35	P9950035	SUPPORT ROD
36	P9950036	RACK GEAR
37	P9950037	PINION GEAR
38	P9950038	HANDLE SHAFT GEAR



Label Placement and Parts

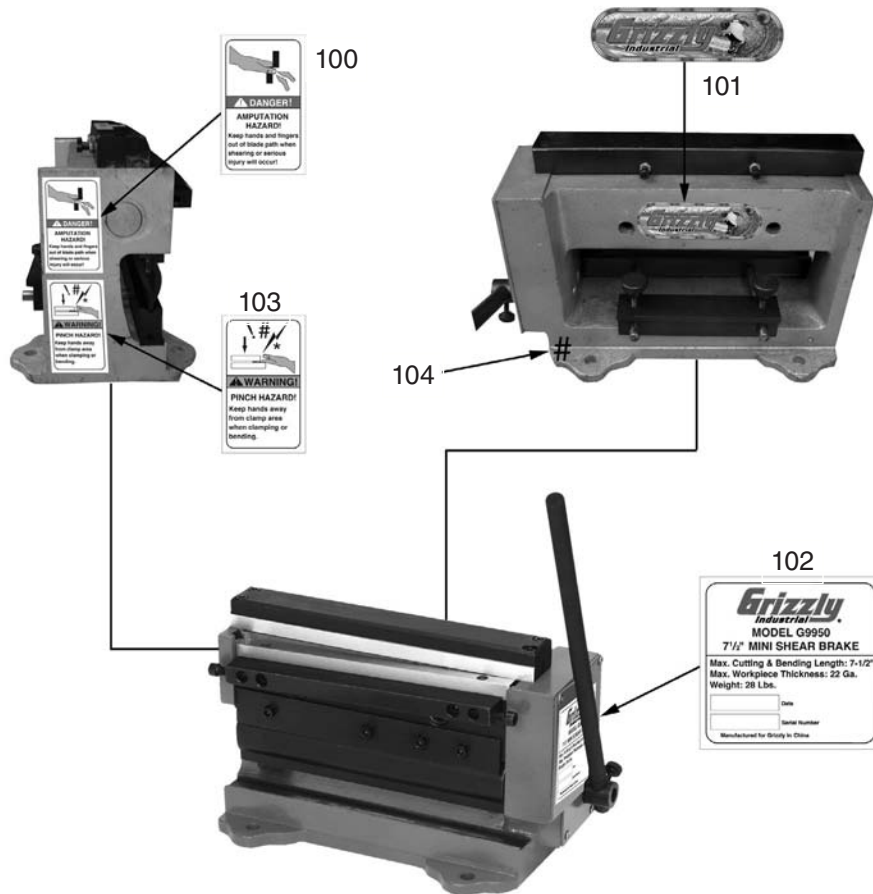

REF	PART #	DESCRIPTION
100	P9950100	AMPUTATION WARNING LABEL
101	P9950101	GRIZZLY LOGO LABEL
102	P9950102	MACHINE DATA LABEL

REF	PART #	DESCRIPTION
103	P9950103	PINCH WARNING LABEL
104	PPAINT-1	GRIZZLY GREEN PAINT

WARNING

Safety labels warn about machine hazards and ways to prevent injury. The owner of this machine **MUST** maintain the original location and readability of the labels on the machine. If any label is removed or becomes unreadable, **REPLACE** that label before using the machine again. Contact Grizzly at (800) 523-4777 or www.grizzly.com to order new labels.

