

Parts Breakdown

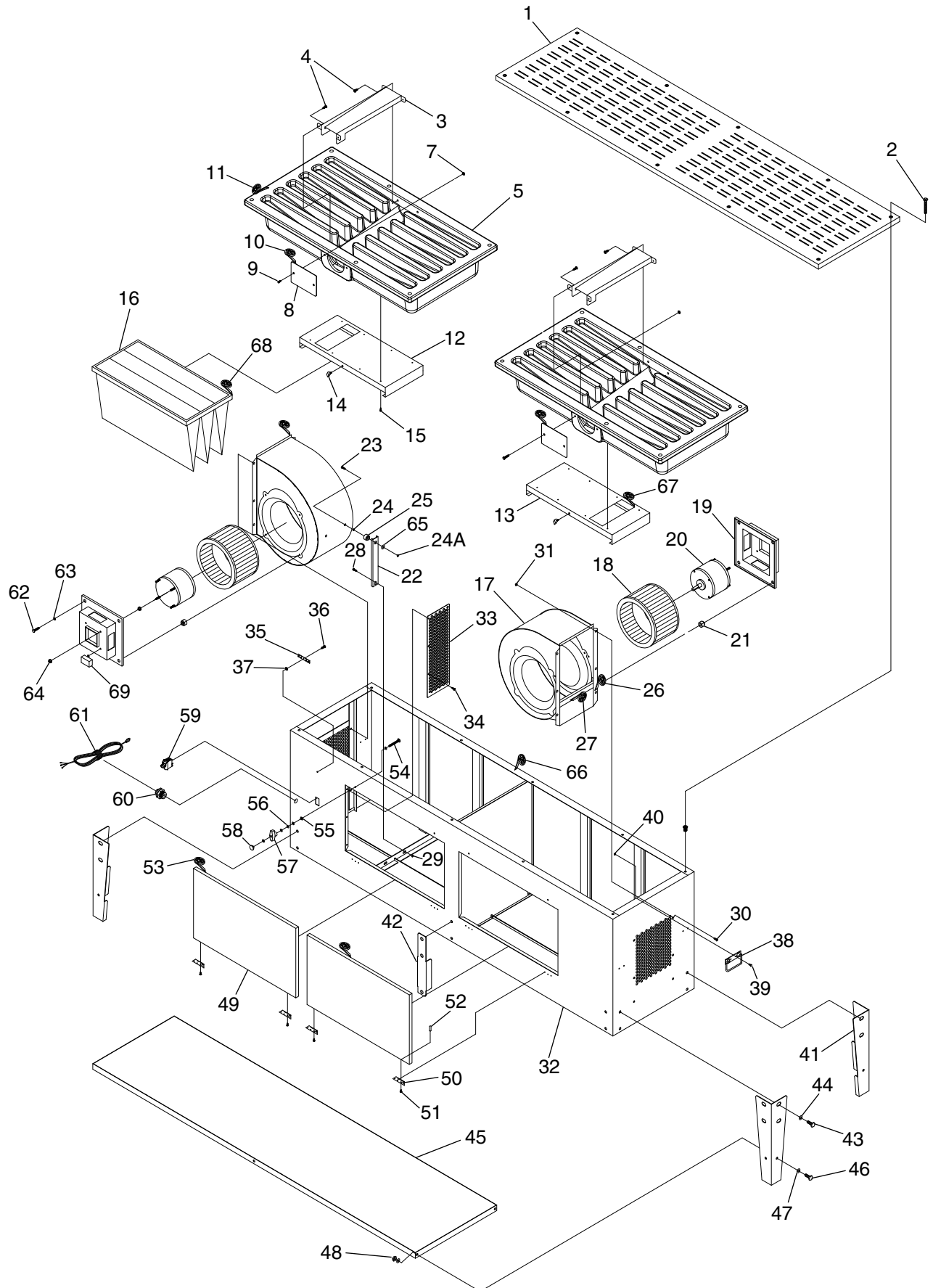

Parts List

REF	PART #	DESCRIPTION
1	P0630001	TABLE TOP
2	PFH15	FLAT HD SCR 1/4-20 X 1 1/2
3	P0630003	DUST DEFLECTOR
4	PHTEK5M	TAP SCREW M4 X 12
5	P0630005	TABLE BASE
7	PN05	HEX NUT 1/4-20
8	P0630008	OUTLET COVER
9	PB31	HEX BOLT 1/4-20 X 1
10	P0630010	GASKET 3 X 6 X 550MM
11	P0630011	GASKET 3 X 6 X 270MM
12	P0630012	DUST FILTER CASE LEFT
13	P0630013	DUST FILTER CASE RIGHT
14	P0630014	KNOB M6-1 X 14
15	PHTEK37M	TAP SCREW M5 X 12
16	P0630016	FILTER BAG
17	P0630017	BLOWER HOUSING
18	P0630018	IMPELLER
19	P0630019	MOTOR SUPPORT
20	P0630020	MOTOR ODP 1/2HP 110V/60HZ
21	P0630021	RUBBER WASHER
22	P0630022	BLOWER BRACKET
23	PB12	HEX BOLT 5/16-18 X 1-1/4
24	PN02	HEX NUT 5/16-18
24A	PFN02	FLANGE NUT 5/16-18
25	P0630025	RUBBER WASHER
26	P0630026	GASKET 3 X 25 X 420MM
27	P0630027	GASKET 3 X 25 X 220MM
28	PB07	HEX BOLT 5/16-18 X 3/4
29	PFN02	FLANGE NUT 5/16-18
30	PFH05	FLAT HD SCR 1/4-20 X 3/4
31	PFN01	FLANGE NUT 1/4-20
32	P0630032	TABLE CABINET
33	P0630033	DIVIDER
34	PHTEK5M	TAP SCREW M4 X 12
35	P0630035	GROUNDING PLATE

REF	PART #	DESCRIPTION
36	PHTEK37M	TAP SCREW M5 X 12
37	PTLW02M	EXT TOOTH WASHER M5
38	P0630038	HANDLE
39	PS38M	PHLP HD SCR M4-.7 X 10
40	PN04M	HEX NUT M4-.7
41	P0630041	CORNER LEG
42	P0630042	MIDDLE LEG
43	PB07	HEX BOLT 5/16-18 X 3/4
44	PW07	FLAT WASHER 5/16
45	P0630045	BASE SHELF
46	PB07	HEX BOLT 5/16-18 X 3/4
47	PW07	FLAT WASHER 5/16
48	PN02	HEX NUT 5/16-18
49	P0630049	CABINET DOOR
50	P0630050	DOOR HINGE
51	PS38M	PHLP HD SCR M4-.7 X 10
52	PN04M	HEX NUT M4-.7
53	P0630053	GASKET 3 X 6 X 2.1MM
54	PS54M	PHLP HD SCR M5-.8 X 45
55	PN06M	HEX NUT M5-.8
56	PW03	FLAT WASHER #10
57	P0630057	KNOB 5/16-18
58	P0630058	KNOB M5-.8
59	P0630059	SWITCH
60	P0630060	STRAIN RELIEF
61	P0630061	POWER CORD
62	PB31	HEX BOLT 1/4-20 X 1
63	PW06	FLAT WASHER 1/4
64	PFN04M	FLANGE NUT M5-.8
65	PW07	FLAT WASHER 5/16
66	P0630066	GASKET 3 X 6 X 5.1MM
67	P0630067	GASKET 3 X 6 X 700MM
68	P0630068	GASKET 3 X 6 X 590MM
69	P0630069	CAPACITOR 16MF 250V



Safety Label Placement

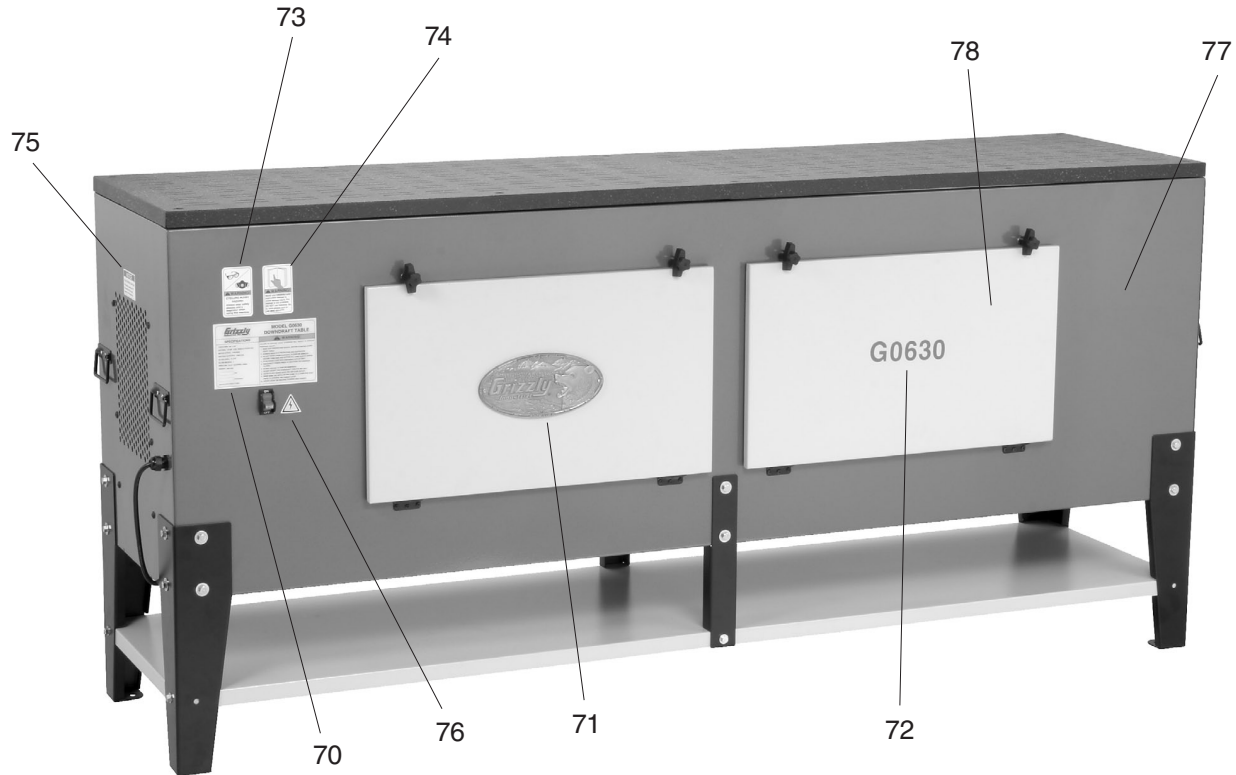

REF	PART #	DESCRIPTION
70	P0630070	MACHINE ID LABEL
71	G8588	GRIZZLY NAME PLATE
72	P0630072	MODEL NUMBER LABEL
73	PLABEL-37	EYE-LUNG WARNING LABEL
74	PLABEL-12	READ MANUAL LABEL

REF	PART #	DESCRIPTION
75	P0630075	AIRFLOW NOTICE LABEL
76	PLABEL-14	ELECTRICITY LABEL
77	PPAINT-1	GRIZZLY GREEN TOUCHUP PAINT
78	PPAINT-11	GRIZZLY PUTTY TOUCHUP PAINT

WARNING

Safety labels warn about machine hazards and ways to prevent injury. The owner of this machine **MUST** maintain the original location and readability of the labels on the machine. If any label is removed or becomes unreadable, **REPLACE** that label before using the machine again. Contact Grizzly at (800) 523-4777 or www.grizzly.com to order new labels.

