



MODEL SB1248 MILLING MACHINE VISE INSPECTION CARD

MODEL: _____ SERIAL NO: _____

INSPECTOR: _____ DATE: _____

#	Item	Acceptable Tolerance	Actual Tolerance
1	Body Height	2.25" ± 0.0005"	
2	Parallelism of Vise Base to Bed	0.0006"	
3	Squareness of Jaws to Vise Bed	0.0005"	

MODEL SB1248

PARTS BREAKDOWN

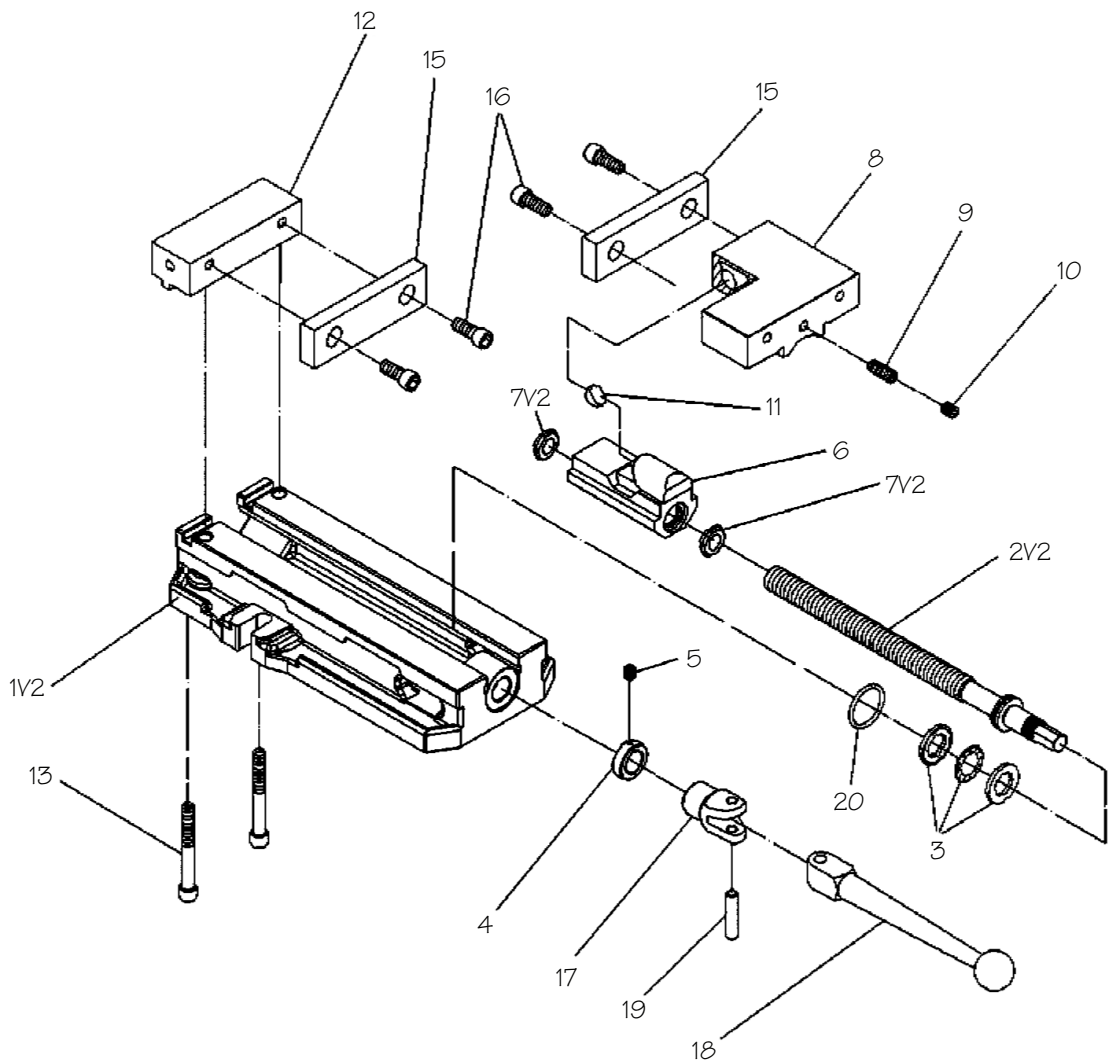

REF	PART #	DESCRIPTION
1V2	PSB1248001V2	WISE BASE V2.06.14
2V2	PSB1248002V2	WISE LEADSCREW 364MM V2.06.14
3	PSB1248003	THRUST BEARING 17 X 36MM
4	PSB1248004	LOCK COLLAR
5	PSB1248005	SET SCREW 5/16-18 X 5/16
6	PSB1248006	WISE LEADSCREW NUT
7V2	PSB1248007V2	LEADSCREW BRUSH V2.06.14
8	PSB1248008	MOVABLE JAW
9	PSB1248009	SET SCREW 3/8-16 X 1
10	PSB1248010	SET SCREW 3/8-16 X 3/8

REF	PART #	DESCRIPTION
11	PSB1248011	WOODRUFF KEY 16MM
12	PSB1248012	FIXED JAW
13	PSB1248013	CAP SCREW 3/8-16 X 2-1/4
15	PSB1248015	JAW PLATE
16	PSB1248016	CAP SCREW 3/8-16 X 1
17	PSB1248017	HANDLE YOKE
18	PSB1248018	HANDLE BAR
19	PSB1248019	SOLID PIN 10 X 41MM
20	PSB1248020	O-RING 23.7 X 3.5 P24

#TR11854 V2.08.14