

# *Grizzly* **Industrial, Inc.**®

## **MODEL H8375 PORTABLE FUME EXTRACTOR OWNER'S MANUAL**

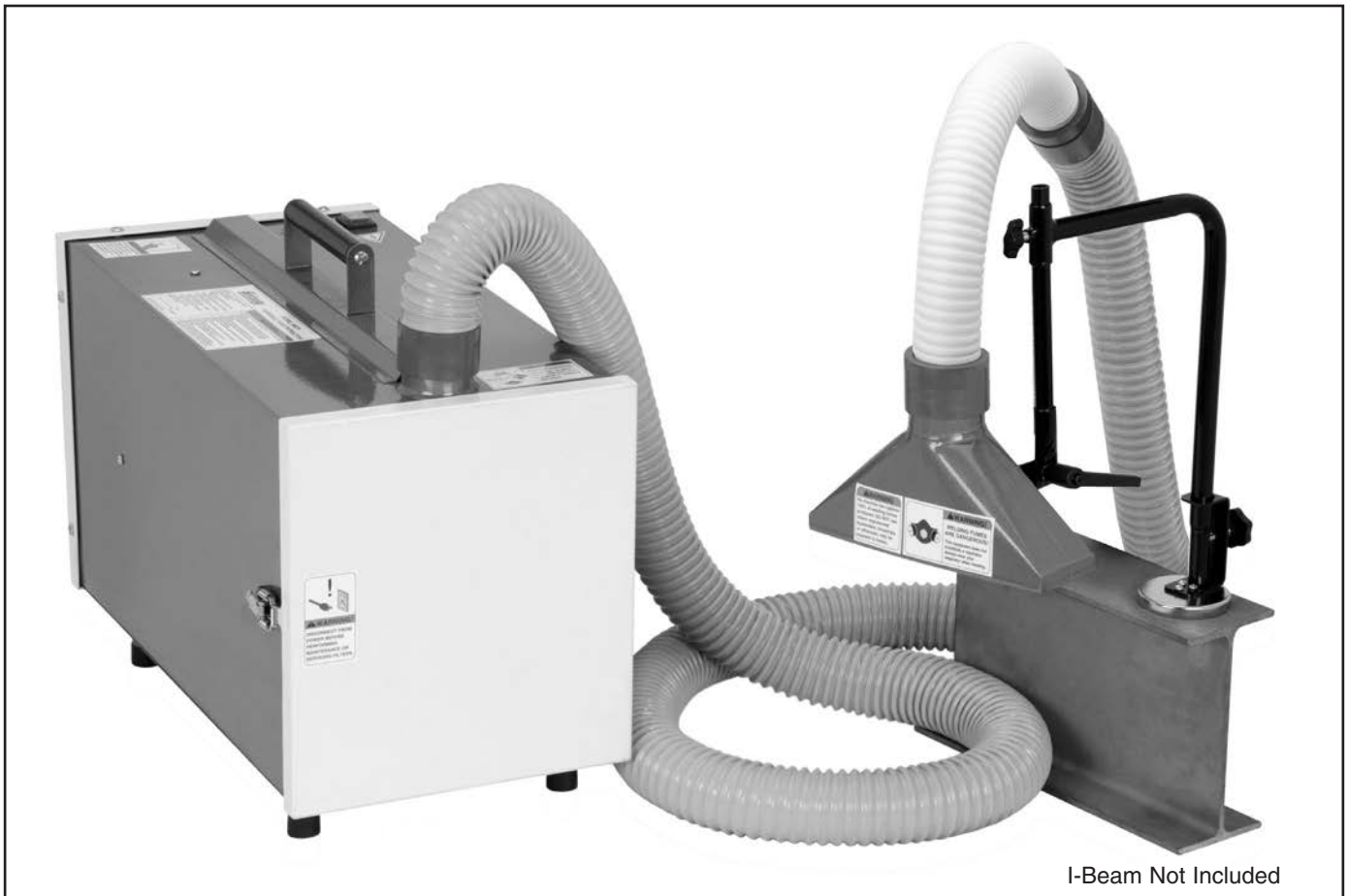

COPYRIGHT © APRIL, 2008 BY GRIZZLY INDUSTRIAL, INC.  
**WARNING: NO PORTION OF THIS MANUAL MAY BE REPRODUCED IN ANY SHAPE  
OR FORM WITHOUT THE WRITTEN APPROVAL OF GRIZZLY INDUSTRIAL, INC.**  
#CR10480 PRINTED IN TAIWAN



## **WARNING!**

**This manual provides critical safety instructions on the proper setup, operation, maintenance, and service of this machine/tool. Save this document, refer to it often, and use it to instruct other operators.**

**Failure to read, understand and follow the instructions in this manual may result in fire or serious personal injury—including amputation, electrocution, or death.**

**The owner of this machine/tool is solely responsible for its safe use. This responsibility includes but is not limited to proper installation in a safe environment, personnel training and usage authorization, proper inspection and maintenance, manual availability and comprehension, application of safety devices, cutting/sanding/grinding tool integrity, and the usage of personal protective equipment.**

**The manufacturer will not be held liable for injury or property damage from negligence, improper training, machine modifications or misuse.**



## **WARNING!**

**Some dust created by power sanding, sawing, grinding, drilling, and other construction activities contains chemicals known to the State of California to cause cancer, birth defects or other reproductive harm. Some examples of these chemicals are:**

- **Lead from lead-based paints.**
- **Crystalline silica from bricks, cement and other masonry products.**
- **Arsenic and chromium from chemically-treated lumber.**

**Your risk from these exposures varies, depending on how often you do this type of work. To reduce your exposure to these chemicals: Work in a well ventilated area, and work with approved safety equipment, such as those dust masks that are specially designed to filter out microscopic particles.**

# Table of Contents

<p><b>INTRODUCTION ..... 2</b></p> <ul style="list-style-type: none"> <li>Foreword ..... 2</li> <li>Contact Info..... 2</li> <li>Functional Overview ..... 2</li> <li>Machine Data Sheet ..... 3</li> <li>Identification ..... 5</li> </ul> <p><b>SECTION 1: SAFETY ..... 6</b></p> <ul style="list-style-type: none"> <li>Safety Instructions for Machinery ..... 6</li> <li>Safety Instructions for Fume Extractors ..... 8</li> <li>Meeting Welding Fume Extraction Codes and Standards..... 9</li> </ul> <p><b>SECTION 2: CIRCUIT REQUIREMENTS ..... 10</b></p> <ul style="list-style-type: none"> <li>110V Operation..... 10</li> </ul> <p><b>SECTION 3: SETUP ..... 11</b></p> <ul style="list-style-type: none"> <li>Setup Safety ..... 11</li> <li>Items Needed for Setup..... 11</li> <li>Unpacking ..... 11</li> <li>Inventory ..... 12</li> <li>Hardware Recognition Chart ..... 13</li> <li>Site Considerations..... 14</li> <li>Assembly ..... 15</li> <li>Suction Hood/Ducting Installation..... 16</li> <li>Control Panel ..... 16</li> <li>Test Run ..... 16</li> </ul>	<p><b>SECTION 4: OPERATIONS ..... 17</b></p> <ul style="list-style-type: none"> <li>Operation Safety ..... 17</li> <li>General Operation ..... 17</li> </ul> <p><b>SECTION 5: ACCESSORIES ..... 18</b></p> <p><b>SECTION 6: MAINTENANCE..... 21</b></p> <ul style="list-style-type: none"> <li>Schedule ..... 21</li> <li>Cleaning..... 21</li> <li>Long-Term Storage..... 21</li> <li>Slag Catch and Screen Cleaning ..... 22</li> <li>Consumable Filter Replacement ..... 22</li> <li>Serviceable Filter Cleaning ..... 23</li> </ul> <p><b>SECTION 7: SERVICE ..... 24</b></p> <ul style="list-style-type: none"> <li>Troubleshooting ..... 24</li> <li>Motor Brush Replacement ..... 25</li> <li>Wiring Diagram ..... 26</li> <li>Electrical Components ..... 27</li> <li>Parts Breakdown..... 28</li> <li>Parts List..... 29</li> <li>Label Placement ..... 30</li> </ul> <p><b>WARRANTY AND RETURNS ..... 33</b></p>
---	--



# INTRODUCTION

---

---

## Foreword

---

---

We are proud to offer the Model H8375 Portable Fume Extractor. This machine is part of a growing Grizzly family of fine metalworking machinery. When used according to the guidelines set forth in this manual, you can expect years of trouble-free, enjoyable operation and proof of Grizzly's commitment to customer satisfaction.

The specifications, drawings, and photographs illustrated in this manual represent the Model H8375 when the manual was prepared. However, owing to Grizzly's policy of continuous improvement, changes may be made at any time with no obligation on the part of Grizzly.

For your convenience, we always keep current Grizzly manuals available on our website at **www.grizzly.com**. Any updates to your machine will be reflected in these manuals as soon as they are complete. Visit our site often to check for the latest updates to this manual!

## Contact Info

---

---

We stand behind our machines. If you have any service questions, parts requests or general questions about the machine, please call or write us at the location listed below.

Grizzly Industrial, Inc.  
1203 Lycoming Mall Circle  
Muncy, PA 17756  
Phone: (570) 546-9663  
Fax: (800) 438-5901  
E-Mail: techsupport@grizzly.com

If you have any comments regarding this manual, please write to us at the address below:

Grizzly Industrial, Inc.  
% Technical Documentation Manager  
P.O. Box 2069  
Bellingham, WA 98227-2069  
Email: manuals@grizzly.com

## Functional Overview

---

---

This portable fume extractor helps collect and recycle shop air that is contaminated with welding dust, oily smoke, and fumes. However, it is not designed to be the "single-solution" air cleaner, should not substitute respirator or fresh-air type respirator use, and it is not suitable for CNC lasers. Often metals have coatings that produce very poisonous fumes when heated, so make sure that you are familiar with the types of fumes produced by the material that you are welding. Keep your shop in compliance with OSHA welding safety requirements at all times.

The Model H8375 can be permanently connected to a small welding downdraft table or moved to various welding locations. Two squirrel-cage fans are located inside of the cabinet and draw welding dust, smoke, and fumes through the suction hood and then through a series of filters before the air re-enters the shop. This filtration occurs in the following five stages:

### Stage 1

Contaminated air enters the machine through a slag catch tray, and then through a 1-2mm stainless steel screen that arrests sparks, and collects minor welding slag.

### Stage 2

Considered the first consumable pleated filter, this filter collects 35% of the 2-10 micron welding dust and most of the oily smoke.

### Stage 3

The second consumable pleated filter catches 85% of the 1-2 micron dust and the remaining oily smoke.

### Stage 4

This serviceable-type pleated filter, catches 45% of the 1-micron size particles.

### Stage 5

This HEPA filter catches 99.97% of the 0.3-micron dust particles before the recycled air finally exits the machine and reenters the shop.





# MACHINE DATA SHEET

Customer Service #: (570) 546-9663 • To Order Call: (800) 523-4777 • Fax #: (800) 438-5901

## MODEL H8375 PORTABLE FUME EXTRACTOR

### Product Dimensions:

Weight ..... 46 lbs  
 Length/Width/Height ..... 24½" x 14" x 19"  
 Foot Print (Length/Width) ..... 24½" x 14"

### Shipping Dimensions:

Type ..... Cardboard  
 Content ..... Machine  
 Weight ..... 49 lbs.  
 Length/Width/Height ..... 27<sup>9</sup>/<sub>16</sub>" x 18<sup>3</sup>/<sub>4</sub>" x 20½"

### Electrical:

Switch ..... Rubber Enclosed Rocker Switch  
 Switch Voltage ..... 110V  
 Cord Length ..... 9 ft.  
 Cord Gauge ..... 14 gauge  
 Minimum Circuit Size ..... 20 AMP  
 Included Plug ..... Yes

### Motors:

#### Main

Quantity ..... 2  
 Type ..... Universal  
 Horsepower ..... 1HP  
 Voltage ..... 110V  
 Phase ..... Single  
 Amps ..... 15A  
 Speed ..... 19,000 RPM  
 Cycle ..... 60 Hz  
 Number of Speeds ..... 1  
 Power Transfer ..... Direct Drive

### Main Specifications:

Cubic Feet Per Minute ..... 230  
 Intake Diameter ..... 2½"  
 Filter Stage 1 Type/Micron ..... Stainless Mesh/1-2mm  
 Filter Stage 1 Dimensions ..... 13½" x 12"  
 Filter Stage 2 Type/Micron ..... Prefilter/2-10 Micron  
 Filter Stage 2 Dimensions ..... 12" x 12" x 2"  
 Filter Stage 3 Type/Micron ..... Prefilter/1-2 Micron  
 Filter Stage 3 Dimensions ..... 12" x 12" x 2"  
 Filter Stage 4 Type/Micron ..... Pleated Filter/1 Micron  
 Filter Stage 4 Dimensions ..... 12" x 12" x 4"  
 Filter Stage 5 Type/Micron ..... HEPA Filter/0.3 Micron  
 Filter Stage 5 Dimensions ..... 12" x 12" x 3"  
 Impeller Type ..... Aluminum  
 Impeller Size ..... 5"  
 Outlet Size ..... 8<sup>3</sup>/<sub>16</sub>" x 2¼"



**Construction**

Body Construction.....Steel  
Hood and Support Construction .....Steel  
Flex Hose Construction.....PVC  
Work Area Flex Hose Construction ..... Fire Resistant PVC  
Paint .....Epoxy/Powder Coat

**Other Specifications:**

Country Of Origin..... Taiwan  
Warranty..... 1 Year  
Serial Number Location ..... ID Label on Top of the Machine

**Features:**

Five Stage Filter System  
Service Filter Warning Light  
8' Flex Hose  
21" Work Area Flex Hose  
2½" x 10" Hood  
Adjustable Hood Support With Magnetic and Clamp-on Bases



# Identification

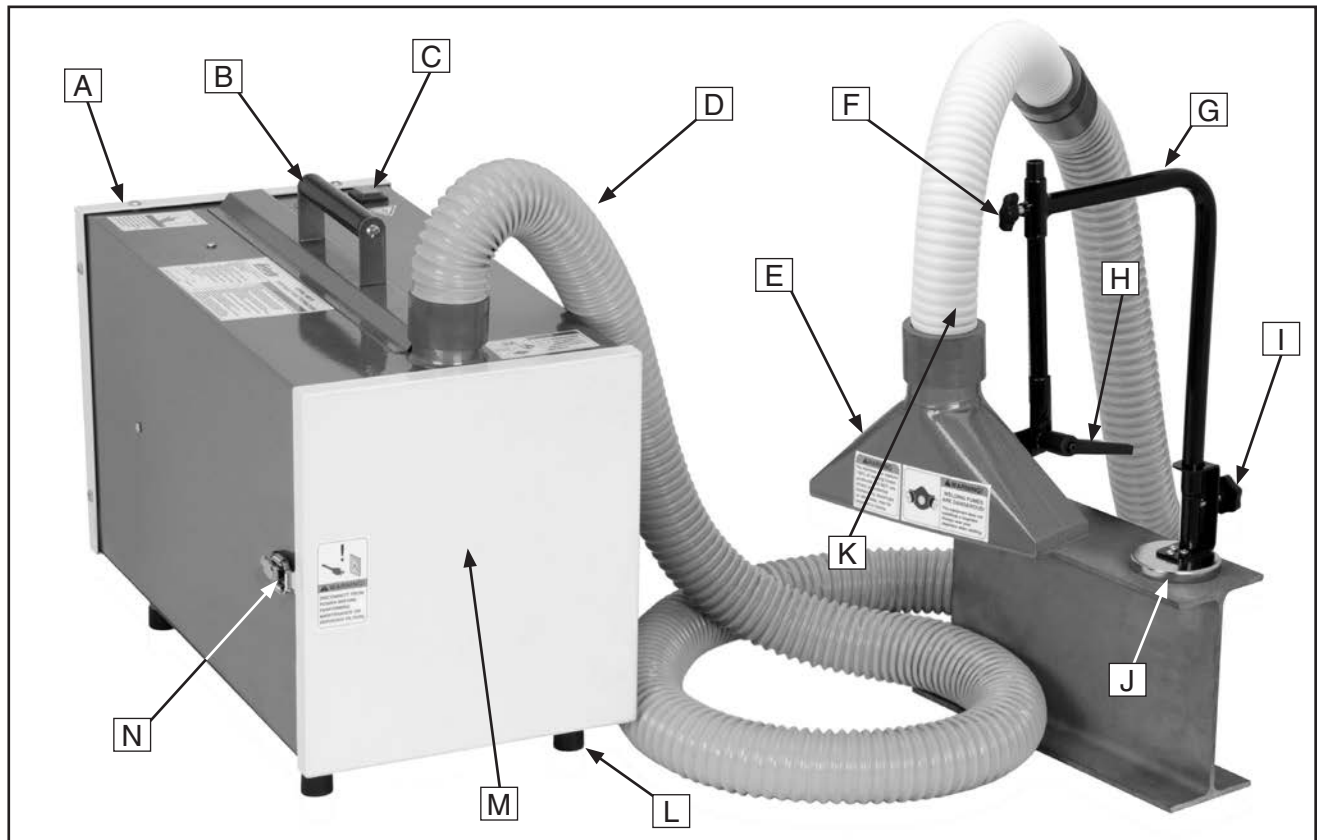

Figure 1. Features.

- A. Motor and Fan Access Cover:** Allows for motor, fan, and electrical system access.
- B. Lifting Handle:** Serves as a steady support for lifting and transporting unit.
- C. Power Switch:** Controls machine operation.
- D. PVC Suction Hose:** A very flexible hose for easy suction hood positioning.
- E. Suction Hood:** Directs suction to specific welding location.
- F. Suction Hood Height Lock Knob:** Locks suction hood in place at a particular height above the workpiece.
- G. Suction Hood Support System:** Allows for universal positioning of the suction hood.
- H. Suction Hood Lock Lever:** Locks suction hood into a specific position.
- I. Suction hood Rotation Lock Knob:** Allows for locking the suction hood support system in place after rotating it.
- J. Magnetic Suction Hood Support Base:** Allows for magnetic mounting of suction hood system.
- K. Fire Resistant Hose:** Gives fire protection while located in welding work area.
- L. Rubber Feet:** Provides for non-scratching positioning of the unit, and dampens any machine vibration.
- M. Service Cover:** Allows access to screen and filters for maintenance.
- N. Quick Service Latch:** Allows for quick and easy screen and filter access.



# SECTION 1: SAFETY

## **WARNING**

### **For Your Own Safety, Read Instruction Manual Before Operating this Machine**

The purpose of safety symbols is to attract your attention to possible hazardous conditions. This manual uses a series of symbols and signal words intended to convey the level of importance of the safety messages. The progression of symbols is described below. Remember that safety messages by themselves do not eliminate danger and are not a substitute for proper accident prevention measures.



Indicates an imminently hazardous situation which, if not avoided, **WILL** result in death or serious injury.



Indicates a potentially hazardous situation which, if not avoided, **COULD** result in death or serious injury.



Indicates a potentially hazardous situation which, if not avoided, **MAY** result in minor or moderate injury. It may also be used to alert against unsafe practices.

**NOTICE**

This symbol is used to alert the user to useful information about proper operation of the machine.

## **WARNING**

### **Safety Instructions for Machinery**

- 1. READ ENTIRE MANUAL BEFORE STARTING.** Operating machine before reading the manual greatly increases the risk of injury.
- 2. ALWAYS USE ANSI APPROVED SAFETY GLASSES WHEN OPERATING MACHINERY.** Everyday eyeglasses only have impact resistant lenses—they are NOT safety glasses.
- 3. ALWAYS WEAR A NIOSH APPROVED RESPIRATOR WHEN OPERATING MACHINERY THAT PRODUCES DUST.** Most types of dust (wood, metal, etc.) can cause severe respiratory illnesses.
- 4. ALWAYS USE HEARING PROTECTION WHEN OPERATING MACHINERY.** Machinery noise can cause permanent hearing loss.
- 5. WEAR PROPER APPAREL. DO NOT** wear loose clothing, gloves, neckties, rings, or jewelry that can catch in moving parts. Wear protective hair covering to contain long hair and wear non-slip footwear.
- 6. NEVER OPERATE MACHINERY WHEN TIRED OR UNDER THE INFLUENCE OF DRUGS OR ALCOHOL.** Be mentally alert at all times when running machinery.



# WARNING

## Safety Instructions for Machinery

7. **ONLY ALLOW TRAINED AND PROPERLY SUPERVISED PERSONNEL TO OPERATE MACHINERY.** Make sure operation instructions are safe and clearly understood.
8. **KEEP CHILDREN/VISITORS AWAY.** Keep all children and visitors away from machinery. When machine is not in use, disconnect it from power, lock it out, or disable the switch to make it difficult for unauthorized people to start the machine.
9. **UNATTENDED OPERATION.** Leaving machine unattended while its running greatly increases the risk of an accident or property damage. Turn machine **OFF** and allow all moving parts to come to a complete stop before walking away.
10. **DO NOT USE IN DANGEROUS ENVIRONMENTS.** DO NOT use machinery in damp, wet locations, or where any flammable or noxious fumes may exist.
11. **KEEP WORK AREA CLEAN AND WELL LIGHTED.** Clutter and dark shadows may cause accidents.
12. **USE A GROUNDED POWER SUPPLY RATED FOR THE MACHINE AMPERAGE.** Grounded cords minimize shock hazards. Operating machine on an incorrect size of circuit increases risk of fire.
13. **ALWAYS DISCONNECT FROM POWER SOURCE BEFORE SERVICING MACHINERY.** Make sure switch is in OFF position before reconnecting.
14. **MAINTAIN MACHINERY WITH CARE.** Keep blades sharp and clean for best and safest performance. Follow instructions for lubricating and changing accessories.
15. **MAKE SURE GUARDS ARE IN PLACE AND WORK CORRECTLY BEFORE USING MACHINERY.**
16. **REMOVE CHUCK KEYS OR ADJUSTING TOOLS.** Make a habit of never leaving chuck keys or other adjustment tools in/on the machine—especially near spindles!
17. **DAMAGED MACHINERY.** Check for binding or misaligned parts, broken parts, loose bolts, other conditions that may impair machine operation. Always repair or replace damaged parts before operation.
18. **DO NOT FORCE MACHINERY.** Work at the speed for which the machine or accessory was designed.
19. **SECURE WORKPIECE.** Use clamps or a vise to hold the workpiece when practical. A secured workpiece protects your hands and frees both hands to operate the machine.
20. **DO NOT OVERREACH.** Maintain stability and balance at all times when operating machine.
21. **MANY MACHINES CAN EJECT WORKPIECES TOWARD OPERATOR.** Know and avoid conditions that cause the workpiece to "kickback."
22. **STABLE MACHINE.** Machines that move during operations greatly increase the risk of injury and loss of control. Verify machines are stable/secure and mobile bases (if used) are locked before starting.
23. **CERTAIN DUST MAY BE HAZARDOUS** to the respiratory systems of people and animals, especially fine dust. Be aware of the type of dust you are exposed to and always wear a respirator designed to filter that type of dust.
24. **EXPERIENCING DIFFICULTIES.** If at any time you are experiencing difficulties performing the intended operation, stop using the machine! Contact our Technical Support Department at (570) 546-9663.



# WARNING

## Safety Instructions for Fume Extractors

- 1. WELDING FUMES.** Welding fumes are hazardous and can cause lung damage without warning. Keep your face away from welding fumes, and position the suction hood near the arc to draw in all fumes from your workstation breathing area. Use an ANSI approved respirator for the applicable type of welding operation, and protect others from these fumes.
- 2. WELDING IN A CONFINED SPACE CAN BE HAZARDOUS.** Do not use this fume extractor in confined spaces without adequate ventilation. Fume extractors do not replace oxygen that is consumed by welding and cutting operations. Suffocation can occur if this warning is ignored. Always open all covers, doors, and windows to sustain fresh air ventilation. Wear an air line respirator, and always work with a partner who can immediately give you help from outside of the welding area.
- 3. CORRECT FILTRATION.** Never modify this fume extractor for any other purpose than it was designed for. Only operate the fume extractor with all filters in place. If any filter is missing or has been replaced with a non-specification filter, the fume extractor will not properly recycle contaminated air and will be unsafe to use.
- 4. EQUIPMENT MAINTENANCE.** Make sure equipment inspections and maintenance are performed by a qualified person and keep all seals and gaskets leak free. Stop the welding operation if the fume extractor is leaking or malfunctions. Repair the fume extractor before using again.
- 5. FILTER CLEANING/DISPOSAL.** When servicing filters, make sure that you and any bystanders are wearing appropriate respirators and body protection. When vacuuming filters and cabinet, only use a shop vacuum that is equipped with a HEPA filter, or dangerous particles may be spread throughout your shop contaminating the air for everyone. Wrap all waste filters in air-tight plastic bags, mark and dispose of according to current laws and regulations.
- 6. CORRECT USAGE.** Never use this fume collector to collect burning slag or molten metal from cutting and welding operations. Always position the suction hood to only collect smoke and fumes.
- 7. EXPERIENCING DIFFICULTIES.** Keep in mind that all normal welding hazards are intensified in a confined space. If you are experiencing difficulties performing the intended operation, stop using the equipment. Contact our Technical Support Department at (570) 546-9663.

### WARNING

Like all machinery there is potential danger when operating this machine. Accidents are frequently caused by lack of familiarity or failure to pay attention. Use this machine with respect and caution to lessen the possibility of operator injury. If normal safety precautions are overlooked or ignored, serious personal injury may occur.

### CAUTION

No list of safety guidelines can be complete. Every shop environment is different. Always consider safety first, as it applies to your individual working conditions. Use this and other machinery with caution and respect. Failure to do so could result in serious personal injury, damage to equipment, or poor work results.



# Meeting Welding Fume Extraction Codes and Standards

---

---

Welding, cutting, brazing, or soldering of metals can give off poisonous fumes containing zinc, lead, beryllium, cadmium, mercury, fluorine, and hexavalent chromium and others. These fumes typically originate from fluxes, solders, anti-corrosion coatings, pigments, metal fillers, and residual chemicals on the workpiece. This machine is designed to help meet the new welding shop clean air requirements mandated by OSHA beginning in 2006. The Model H8375 Portable Fume Extractor is designed to be a part of an overall fume control system. It is NOT designed to serve as a "single-solution" for keeping workers safe from all welding fumes. You must contact OSHA to find out how to design and maintain the best overall welding fume control system for your work station or shop. Often, depending on the workspace size, volume of work, type of material to be welded, or other special circumstances, you must use additional safety equipment such as personal air line respirators, hoods, masks, and complete body protection.

Contact the organizations below to help you meet welding fume extraction requirements:

**Occupational Safety and Health Administration (OSHA).**

—Code of Federal Regulations, Title 29 Labor, Parts 1910.1 to 1910.1450, available from the U.S. Government Printing Office, Superintendent of Documents, P.O. Box 371954, Pittsburgh, PA 15250-7954 (telephone: 800-321-6742; web site: [www.osha.gov](http://www.osha.gov)).

**American Welding Society (AWS).**

—Fumes and Gases in the Welding Environment, available from Global Engineering Documents, 15 Inverness Way East, Englewood, CO 80112-5776 (800-854-7179; web site: [www.global.ihs.com](http://www.global.ihs.com)).

**American National Standards Institute (ANSI).**

—Safety in Welding, Cutting, and Allied Processes (ANSI Z49.1), available from Global Engineering Documents, 15 Inverness Way East, Englewood, CO 80112-5776 (telephone: 800-854-7179; web site: [www.global.ihs.com](http://www.global.ihs.com)).

**National Institute for Occupational Safety and Health (NIOSH).**

—Safety and Health in Arc Welding and Gas Welding and Cutting, NIOSH Publication No. 78-138. Cincinnati, OH (telephone: 800-356-4674; web site: <http://www.cdc.gov/niosh>).

**International Agency For Research On Cancer (IARC).**

—Monographs on the Evaluation of Carcinogenic Risks to Humans, Chromium, Nickel, and Welding, Vol. 49 (1990), Oxford University Press, New York, NY 10016 (telephone: 212-726-6000; web site: [www.oup-usa.org](http://www.oup-usa.org)).

**National Fire Protection Association (NFPA),** P. O. Box 9101, 1 Battery March Park, Quincy, MA 02269-9101, (617) 770-3000, Website: [www.nfpa.org](http://www.nfpa.org) and [www.sparky.org](http://www.sparky.org).

—National Electrical Code, NFPA Standard 70

—Standard for Fire Prevention During Welding, Cutting, and Other Hot Work, NFPA Standard 51B

**American Conference of Governmental Industrial Hygienists (ACGIH).**

—Documentation of the Threshold Limit Values and Biological Exposure Indices, available from ACGIH, 1330 Kemper Meadow Drive, Cincinnati, OH 45240-1634 (telephone: 513-742-2020; web site: [www.acgih.org](http://www.acgih.org)).



# SECTION 2: CIRCUIT REQUIREMENTS

## 110V Operation

### **!WARNING**

Serious personal injury could occur if you connect the machine to power before completing the setup process. **DO NOT** connect the machine to the power until instructed later in this manual.

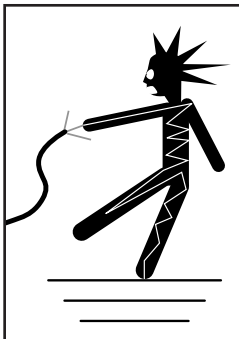

### **!WARNING**

Electrocution or fire could result if machine is not grounded and installed in compliance with electrical codes. Compliance **MUST** be verified by a qualified electrician!

### Full Load Amperage Draw

The dual motors of this machine draw the following amps under maximum load:

Amp Draw..... 15 Amps

### Power Supply Circuit Requirements

You **MUST** connect your machine to a grounded circuit that is rated for the amperage given below. Never replace a circuit breaker on an existing circuit with one of higher amperage without consulting a qualified electrician to ensure compliance with wiring codes. **If you are unsure about the wiring codes in your area or you plan to connect your machine to a shared circuit, consult a qualified electrician.**

Minimum Circuit Size.....20 Amps

### Power Connection Device

The Model H8375 comes with a 5-15 plug, similar to **Figure 2**, to connect the machine to power.

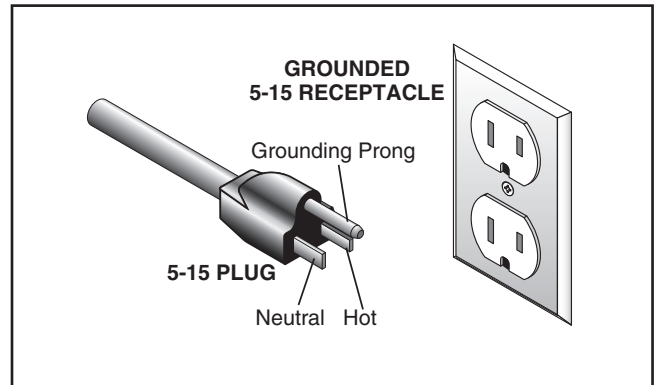
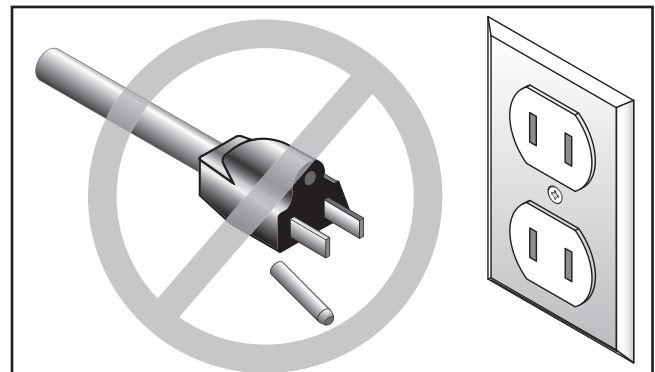

Figure 2. Typical 5-15 plug and receptacle.



### **!CAUTION**

This machine **MUST** have a ground prong in the plug to help ensure that it is grounded. **DO NOT** remove ground prong from plug to fit into a two-pronged outlet! If the plug will not fit the outlet, have the proper outlet installed by a qualified electrician.

### Extension Cords

We do not recommend using extension cords, but if you find it absolutely necessary:

- Use at least a 12 gauge cord that does not exceed 50 feet in length!
- The extension cord must have a ground wire and plug pin.
- A qualified electrician **MUST** size cords over 50 feet long to prevent motor damage.



# SECTION 3: SETUP

## Setup Safety

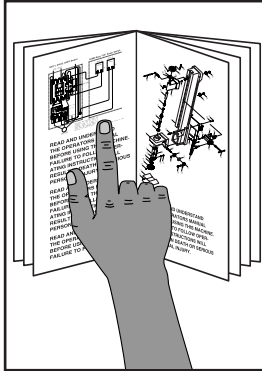

**! WARNING**  
This machine presents serious injury hazards to untrained users. Read through this entire manual to become familiar with the controls and operations before starting the machine!



**! WARNING**  
Wear safety glasses during the entire setup process!

## Items Needed for Setup

The following items are needed to complete the setup process, but are not included with your machine:

Description	Qty
• Wrench 3/8" .....	1
• Wrench 5/16" .....	1
• Phillips Screwdriver #2 .....	1

## Unpacking

Your machine was carefully packaged for safe transportation. Remove the packaging materials from around your machine and inspect it. If you discover the machine is damaged, *please immediately call Customer Service at (570) 546-9663 for advice.*

Save the containers and all packing materials for possible inspection by the carrier or its agent. *Otherwise, filing a freight claim can be difficult.*

When you are completely satisfied with the condition of your shipment, inventory the contents.



# Inventory

The following is a description of the components shipped with your machine. Lay the components out to inventory them.

**Note:** *If you can't find an item on this list, check the mounting location on the machine or examine the packaging materials carefully. Occasionally we pre-install certain components for shipping purposes.*

Inventory: (Figures 3 & 4)	Qty
A. Portable Fume Extractor Unit.....	1
B. Fire Resistant 2" Dia. Suction Hose.....	1
C. PVC 2.5" Dia. Suction Hose.....	1
D. Hood.....	1
E. Hood Lock Lever .....	1
F. Lock Washers $\frac{5}{16}$ " (Hood Lock Lever) .....	2
G. Workbench Mount w/Knobs .....	1
H. Support Arm Lock Knob.....	1
I. Magnetic Base.....	1
J. Philip Head Screws #10-24 x $\frac{3}{8}$ " (Magnetic Base) .....	3
K. Hex Nuts #10-24 (Magnetic Base) .....	3
L. Magnetic Base Support w/Knob.....	1
M. Support Rod Thumb Knob .....	1
N. Support Rod.....	1
O. Support Arm .....	1
P. Hood Bracket.....	1
Q. Flat Washers $\frac{5}{16}$ " (Hood) .....	4
R. Hex Nuts $\frac{5}{16}$ "-18 (Hood).....	2
S. Hex Bolts $\frac{5}{16}$ "-18 X $\frac{3}{4}$ " (Hood) .....	2

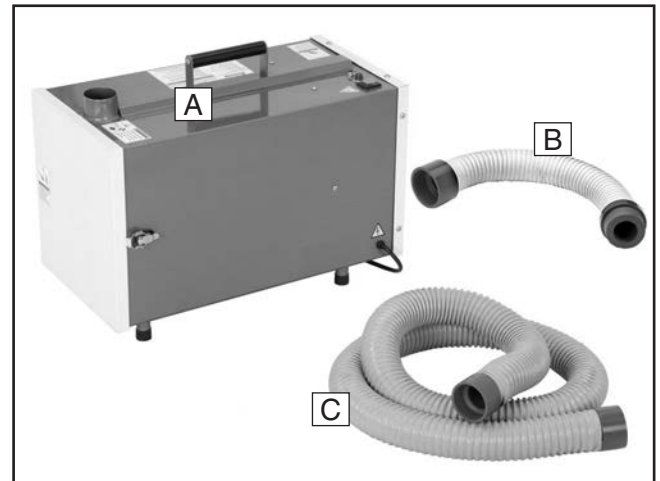

Figure 3. Toolbox and accessories.

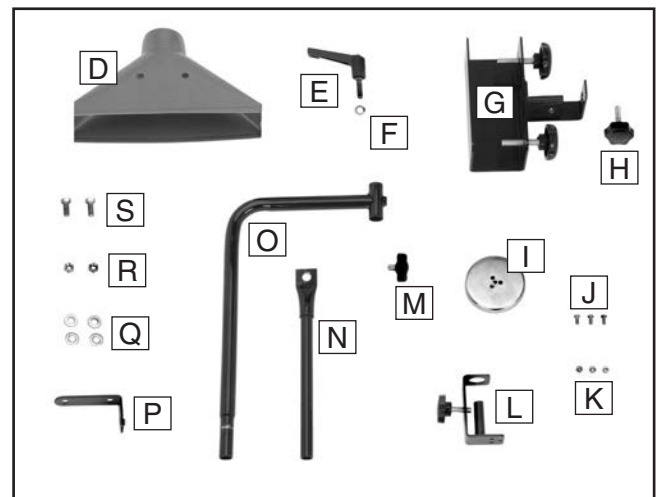



Figure 4. Suction arm assembly.

If any nonproprietary parts are missing (e.g. a nut or a washer), we will gladly replace them; or for the sake of expediency, replacements can be obtained at your local hardware store.

	<p><b>⚠ WARNING</b>  <b>SUFFOCATION HAZARD!</b>  <b>Immediately discard all plastic bags and packing materials to eliminate choking/suffocation hazards for children and animals.</b></p>
---	---



# Hardware Recognition Chart

USE THIS CHART TO MATCH UP HARDWARE DURING THE ASSEMBLY PROCESS.

MEASURE BOLT DIAMETER BY PLACING INSIDE CIRCLE

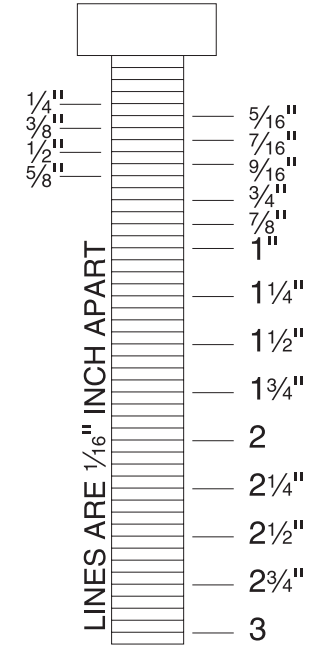
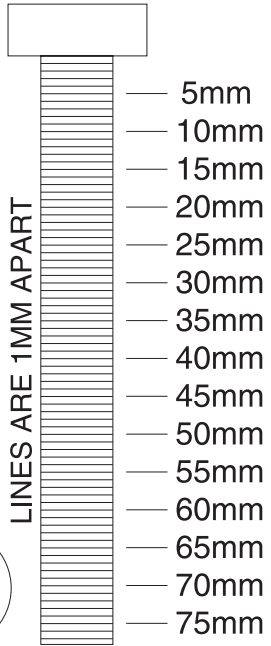
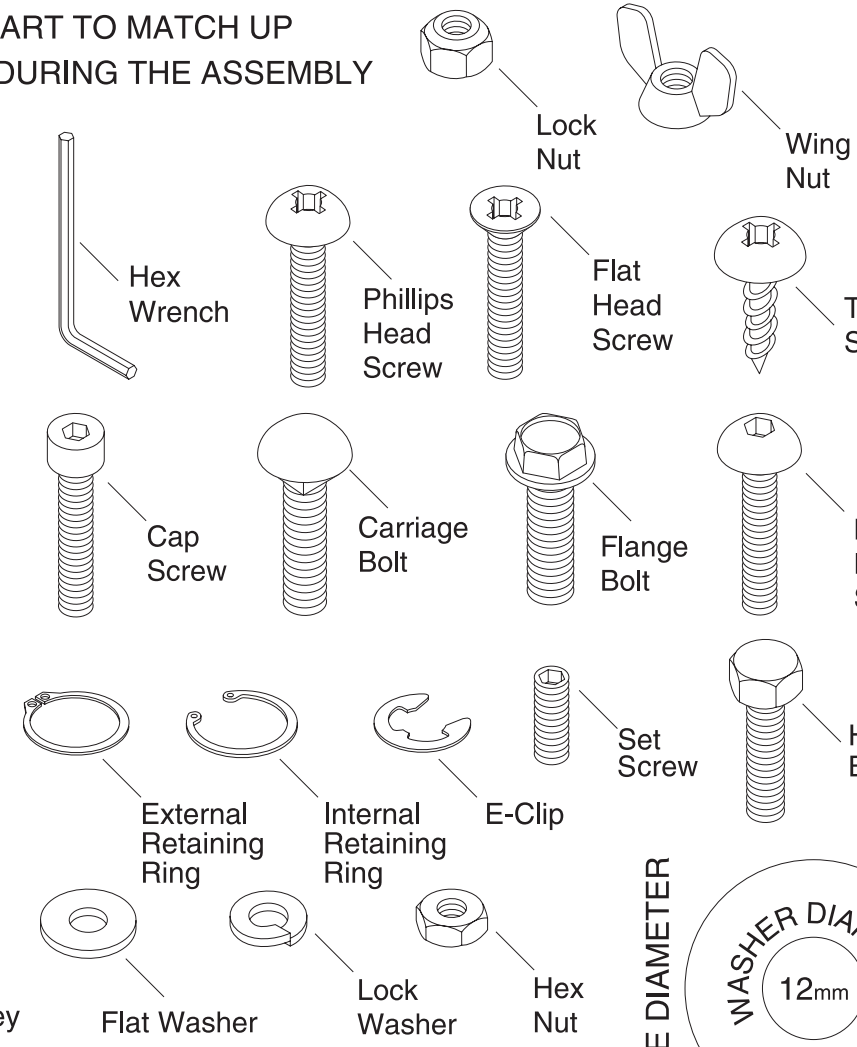
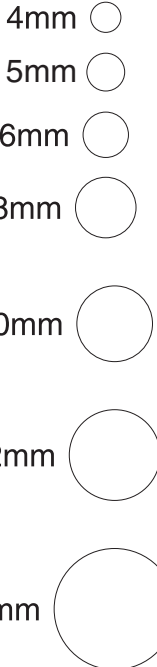
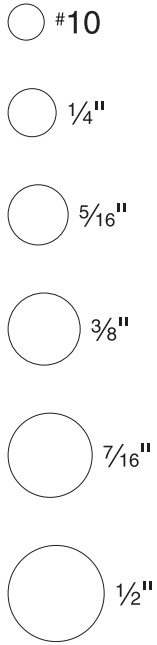

WASHERS ARE MEASURED BY THE INSIDE DIAMETER

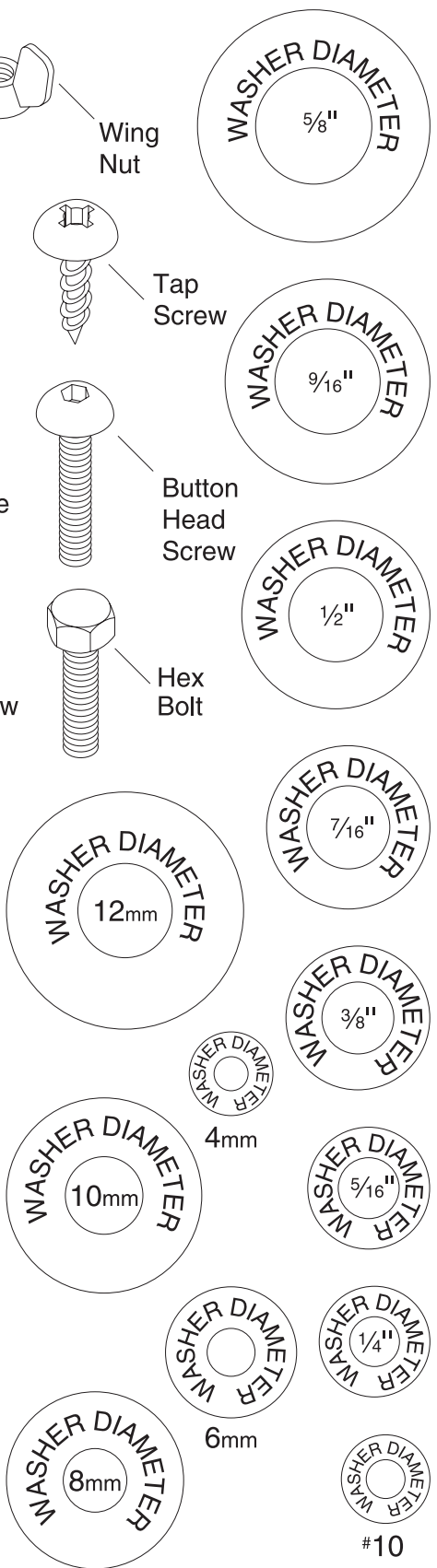

# Site Considerations

## Floor Load

Refer to the **Machine Data Sheet** for the weight and footprint specifications of your machine. Some tool tables or workbenches may require additional reinforcement to support both the machine and the workpiece.

## Placement Location

This machine is designed to operate when the ambient temperature is between 41°F to 122°F, and when the humidity is between 30% and 95%. However, if the machine is only to be used in cycles that are less than 24-hour runs and allowed to cool between the runs, the maximum ambient temperature range for operation can be raised to 133°F.

Consider existing and anticipated needs, size of material to be welded, and space for auxiliary stands, work tables or other machinery when establishing a location for your new machine. See **Figure 5** for the minimum working clearances.

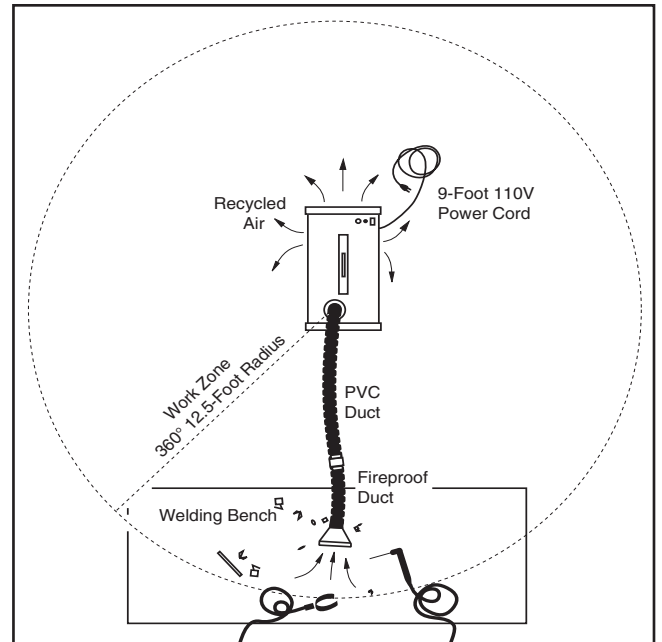
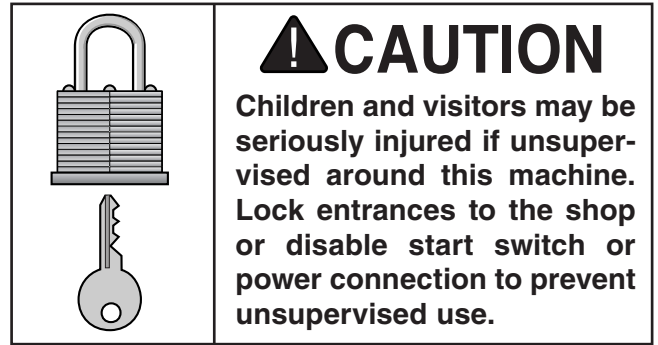

**Figure 5.** Typical working clearances.



# Assembly

Two types of suction hood mounting fixtures need to be assembled. The first type is the clamping base for the edge of a welding bench. The second type is the magnetic base for clamping on metal surfaces. The support arm system and the hood also require assembly.

## To assemble these items:

1. Assemble the hood bracket to the hood using two  $\frac{5}{16}$ "-18 X  $\frac{3}{4}$ " hex bolts, flat washers, and lock washers (**Figure 6**).
2. Secure the hood bracket to the support rod with the lock lever.

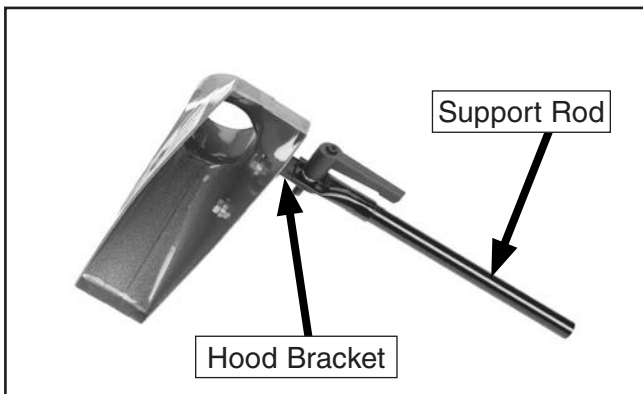

**Figure 6.** Hood and support rod.

3. Place the workbench clamp on the edge of your welding table and tighten in place with the two hand knobs (**Figure 7**).
4. Insert the hood support rod into the workbench clamp, and tighten the lock knob (**Figure 7**) for clamping option 1.

—For clamping option 2, install the support arm as shown in **Figure 8**.

—For the magnetic clamping option, insert the rod into the magnetic base and tighten the knob as shown in **Figure 9**.



**Figure 7.** Work bench clamping option 1.

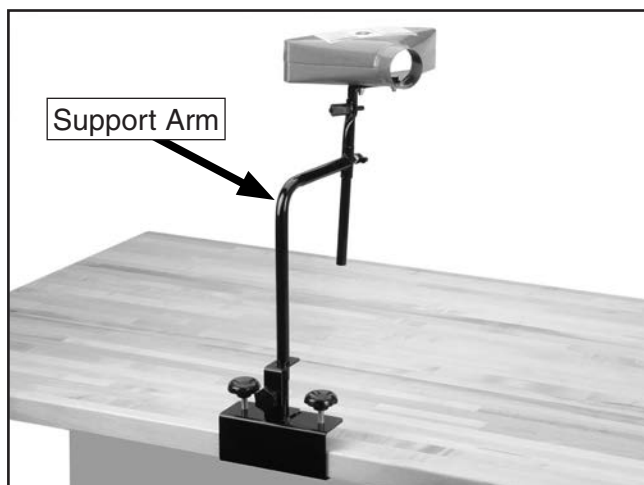

**Figure 8.** Work bench clamping option 2.

5. Use the the three #10-24 x  $\frac{3}{8}$ " Phillips head screws, and the three hex nuts to assemble the magnetic base to the magnetic base support as shown in **Figure 9**.



**Figure 9.** Magnetic base assembly.



# Suction Hood/ Ducting Installation

---

---

Avoid having a suction hose run that is longer than 20 feet or using alternating sizes of ducting connections. Also using too many elbows or tees will dramatically reduce the available CFM at the welding or cutting location.

Before connecting to a welding downdraft table, make sure that it is an approved welding downdraft table that catches and arrests all sparks, slag, and molten metal. This fume collector is only designed to filter out welding dust, smoke, and fumes from contaminated air. **DO NOT** use this machine to directly collect burning slag or molten metal underneath cutting or welding operations.

## Control Panel

---

---

- A. ON/OFF Button:** Toggles machine operation *ON* and *OFF*.
- B. Filter Warning Lamp:** The lamp illuminates when one or more filters are becoming clogged and need cleaning or replacement.
- C. 15-Amp Circuit Breaker:** Protects the machine from overload.

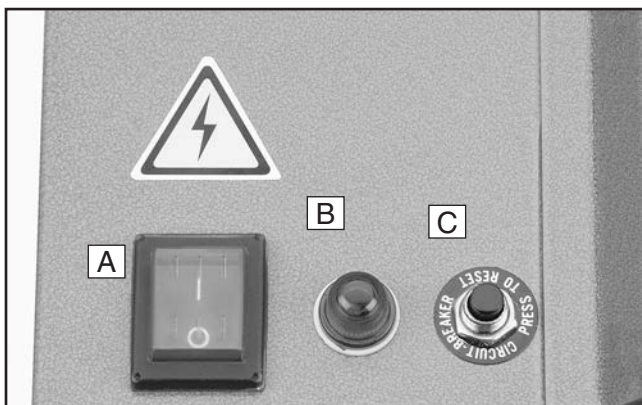

Figure 10. Control panel.

## Test Run

---

---

Once all ducting has been attached, test run your machine to make sure it runs properly.

If, during the test run you cannot easily locate the source of an unusual noise or vibration, stop using the machine immediately, then review the **Troubleshooting on Page 24**.

If you still cannot remedy a problem, contact our Tech Support at (570) 546-9663 for assistance.

### To test run the machine:

1. Refer to the **Maintenance** section on **Page 21**, and make sure that all filters are properly positioned.
2. Make sure all tools and objects used during setup are cleared away from the suction intake, so the suction hood will not draw in any objects when the machine is started.
3. Plug in the machine and press the ON button (**Figure 10**).
4. Let the machine run for at least 1 minute while you evaluate the machine for the following:
  - Listen for whistling sounds coming from end covers or panels, which indicate a poor seal or gasket. Tighten screws and replace foam seal as required.
  - If a fan is not working, or you hear any strange or unusual metallic noise or feel a harmonic vibration, shut the machine **OFF** and correct the problem before operating the machine again. Always disconnect the machine from power when investigating or correcting potential problems.



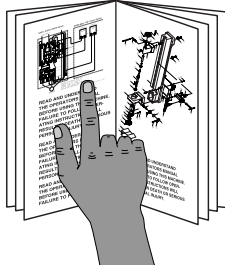

# SECTION 4: OPERATIONS

## Operation Safety

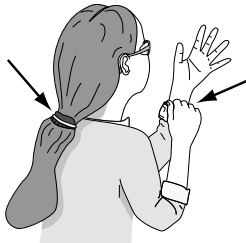

**!WARNING**  
To reduce the risk of serious injury when using this machine, read and understand this entire manual before beginning any operations.

**!WARNING**  
Damage to your eyes and lungs could result from using this machine without proper protective gear. Always wear safety glasses and a respirator when operating this machine.



**!WARNING**  
Loose hair, clothing, or jewelry could get caught in machinery and cause serious personal injury. Keep these items away from moving parts at all times to reduce this risk.

**NOTICE**  
If you have never used this type of machine or equipment before, WE STRONGLY RECOMMEND that you read books, trade magazines, or get formal training before beginning any projects. Regardless of the content in this section, Grizzly Industrial will not be held liable for accidents caused by lack of training.

## General Operation

This portable fume extractor is not designed to be a substitute for a respirator or fresh-air type respirator. Make sure that you are familiar with the materials to be welded and know what types of fumes will be created. Additionally, many metals have coatings that produce poisonous fumes when heated. Make sure to strip coatings off at least four inches away from the area of heat application before welding or cutting.

This machine is not designed to collect burning slag or molten metal from a cutting torch or a plasma cutter operations. In these circumstances, you must use an appropriate welding downdraft table that will arrest all molten metal and slag.

This fume extractor is not suitable for CNC lasers.

Between welding jobs, periodically clean out the slag catch and clean the stainless steel screen (Figure 11). If the type of welding changes drastically or if paint, rubberized undercoating, or other coatings cause excessive smoke, you may have to replace or clean filters more often in order to maintain a satisfactory CFM.

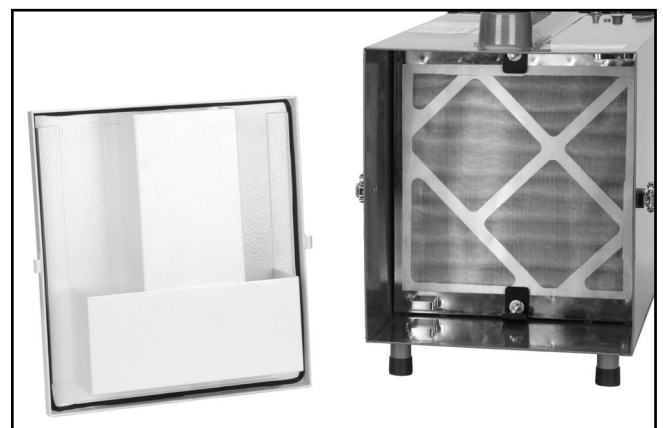

Figure 11. Slag catch and stainless steel screen.

It is always better to follow good welding practices and remove coatings that may smoke and possibly contaminate the weld. This machine does not save you from the task of proper workpiece preparation.



# SECTION 5: ACCESSORIES

## T20635—Stainless Screen (Stage 1)

Made of high-quality stainless steel, this 1-2mm removable mesh arrests sparks and stops hot slag from entering filter stage 1. Make sure that you clean this mesh often and inspect for holes or damage. Under correct use, this screen should last for years.



Figure 12. Stainless Screen (Stage 1).

## T20636—2-10 Micron Filter (Stage 2)

This pleated filter, is the consumable workhorse of your fume extractor. It removes most of the 2-10 micron and larger grit, dust, and oily smoke. Make sure that you have a few of these on hand to be ready for high-volume or dirty welding jobs.

**Note:** Proper workpiece cleaning to reduce the amount of smoke given off during welding is critical for extending stage 2 and 3 filter life.



Figure 13. 2-10 Micron Filter (Stage 2).

## T20637—1-2 Micron Filter (Stage 3)

This pleated filter is also a hard-working particle collector. It will have to be replaced periodically when the stage 2 filter is replaced. Make sure to have a few of these on hand for those high-volume or dirty welding jobs.

**Note:** Proper workpiece cleaning to reduce the amount of smoke given off during welding is critical for extending stage 2 and 3 filter life.



Figure 14. 1-2 Micron Filter (Stage 3).

## T20638—1 Micron Filter (Stage 4)

This serviceable filter, catches most of the remaining 1-micron particles that get through stage 3. This filter does not need to be replaced as often as the consumable filters as it can be removed and cleaned manually a number of times before replacement is required. However, always have an extra ready to be installed.



Figure 15. 1 Micron Filter (Stage 4).

Call 1-800-523-4777 To Order



**T20639— 0.3 Micron HEPA Filter (Stage 5)**

This filter removes 99.97% of the 0.3-micron particles. This filter rarely needs to be replaced as it is also a serviceable filter. If the machine is used properly, and the filter is periodically removed and cleaned manually this filter may last for years.



**Figure 15.** HEPA filter (Stage 5).

**H9748—Leather Jacket Medium (40–42)**

**H9887—Leather Jacket Large (44–46)**

**H9888—Leather Jacket X-Large (48–52)**

**H9746—Leather Knee Pads**

**H9745—Leather Shoe Covers**

These leather jackets, knee pads, and shoe covers provide full protection from welding sparks and spatter. Gloves not included.

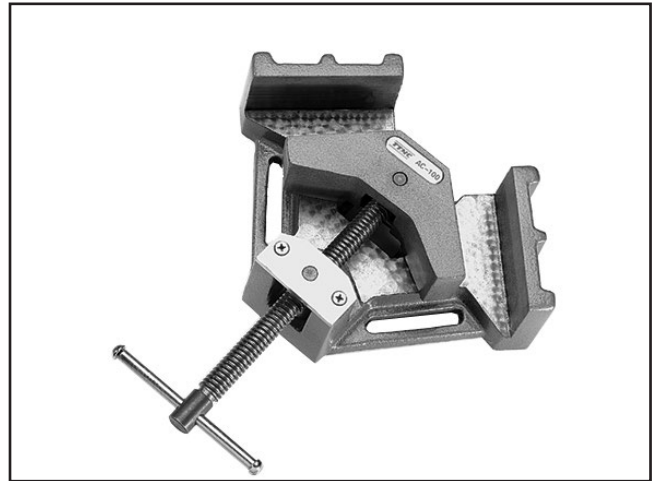

**Figure 16.** Leather welding protection.

**G8028— Small Angle Welding Clamp**

**G8029— Large Angle Welding Clamp**

Take the set up time and effort out of metalworking applications that involve holding material for right angle joining, assembling, welding or grinding. A self-centering jaw quickly adjusts to clamp workpieces, even accommodating pieces of different sizes. The 90° angle clamp is made of high quality cast iron. The spindle, which automatically pivots for an accurate 90° grip, is also copper plated to resist weld spatter. Work surface and base are milled for added precision. Small clamp weighs approximately 12 lbs. Large clamp weighs approximately 29 lbs.



**Figure 17.** Cast-iron welding clamp.

**T20505—Welding Respirator with Valve**

Added flame retardants help reduce the shell flammability, making these N99 Premium Particulate Respirators ideal for welding applications. NIOSH certified to a 99% efficiency for particulates free of oil.



**Figure 18.** Model T20505 welding respirator.

**Call 1-800-523-4777 To Order**



### **H7786—Auto Darkening Welding Helmet**

Automatic UV and IR filters protect eyes from harmful visible and invisible light during welding. Switching time is less than or equal to 2 milliseconds, so there's no need to flip the helmet up to see your work under normal light conditions. Full face protection features adjustable head suspension and adjustable delay time, sensitivity and dark shade protection. Viewing area is 3½" x 1½". Includes 2 AAA batteries.



**Figure 19.** Model H7786 welding helmet.

### **H3157—Deluxe Welding Gloves**

Top grain, leather gloves protect against welding hazards. Extra long to protect wrists and forearms. One size fits all.



**Figure 20.** Model H3157 deluxe welding gloves.

**Call 1-800-523-4777 To Order**



# SECTION 6: MAINTENANCE

---

---

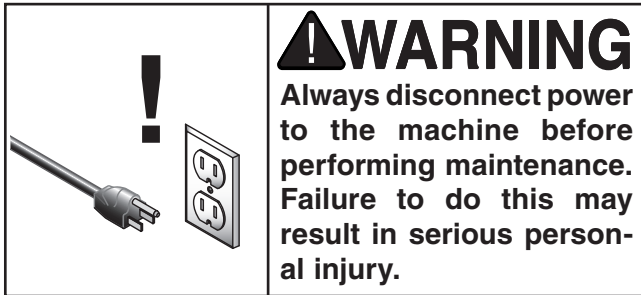

## Schedule

---

---

For optimum performance from your machine, follow this maintenance schedule and refer to any specific instructions given in this section. Always wear an OSHA approved respirator when cleaning this machine.

### Daily Check/Maintenance:

- Leaking seals or ducting.
- Worn or damaged power cord.
- Clean slag catch and screen as required.
- Inspect and correct for any other unsafe condition.
- Inspect welding area before and after welding or cutting operations for fire hazards and smoldering combustibles.

## Cleaning

---

---

Cleaning the Model H8375 is relatively easy. Put on an OSHA approved respirator and vacuum excess dust with a shop vacuum fitted with a HEPA filter. Wipe off the remaining dust with a damp cloth. Do not use harsh detergents or solvents on the cabinet.

### ! WARNING

When servicing filters, make sure that you and any bystanders are wearing appropriate respirators and body protection. When vacuuming filters and cabinet, only use a shop vacuum that is equipped with a HEPA filter, or dangerous particles may be spread throughout your shop and contaminate the air. Wrap all waste filters in air-tight plastic bags, mark and dispose of according to current laws and regulations.

## Long-Term Storage

---

---

If this machine needs to be stored for a long period of time, make sure that the following conditions are met:

- Remove and manually clean the stage 4 and 5 filters.
- Clean the stainless screen and the slag catch.
- Wipe out inside of cabinet and replace stage 2 and 3 filters if required.
- Place the machine in a dry area where the humidity range will not vary beyond 30% to 95% and the storage temperature will not vary beyond -13° to 158°F.
- Cover machine to protect from dust and moisture.



# Slag Catch and Screen Cleaning

Stage 1 (Model T20635) 1-2 mm screen is made of high-quality stainless steel mesh that arrests sparks and stops hot slag from entering the first pleated filter. Make sure that you clean this mesh often and inspect for holes or damage. Under correct use, this screen should last for years.

<b>Tools Needed</b>	<b>Qty</b>
Wire Brush.....	1
OSHA Approved Respirator .....	1
Shop Vacuum w/HEPA Filter .....	1

## To perform this procedure:

1. UNPLUG THE MACHINE!
2. Put on your respirator, unlatch and remove the access cover, wing nuts, and the screen (**Figure 21**).

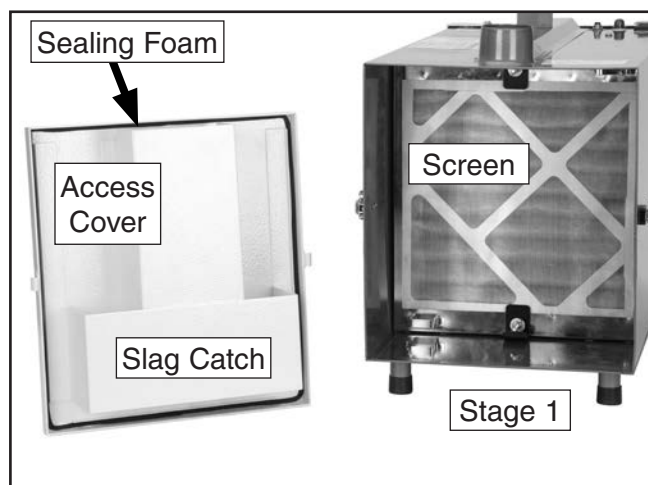

**Figure 21.** Cover and stainless screen.

3. Inspect the cover seal for evidence of leaks or tears. Reseal as required.
4. Tap the screen and carefully use a wire brush to brush away built up dust and slag. If a piece of solder or slag has welded its self to the screen, do not pry it off or you may put a hole in the screen.
5. Vacuum up the loose dust in the cabinet and slag drawer, reinstall the screen and cover.

# Consumable Filter Replacement

Stage 2 (Model T20636) and stage 3 (Model T20637) pleated filters remove most of the larger grit, dust, and oily smoke. Depending on work load and type, one or both may have to be replaced to regain lost CFM. However, do not remove and manually clean the serviceable filters (Stages 4 and 5) every time these consumable filters are replaced, doing so will unnecessarily decrease stage 4 and 5 filter life.

**Note:** *Proper workpiece cleaning to reduce the amount of smoke given off during welding is critical for extending filter life.*

<b>Tools Needed</b>	<b>Qty</b>
OSHA Approved Respirator .....	1

## To perform this procedure:

1. UNPLUG THE MACHINE!
2. Put on your respirator and goggles, unlatch the access cover and remove it (**Figure 21**).
3. Remove the two wing nuts, filter retainers, and then the stainless screen (**Figure 21**).
4. Replace stage 2 and 3 filters so that the flow arrow (**Figure 22**), printed on the edge of the filter, points in the direction of air flow.

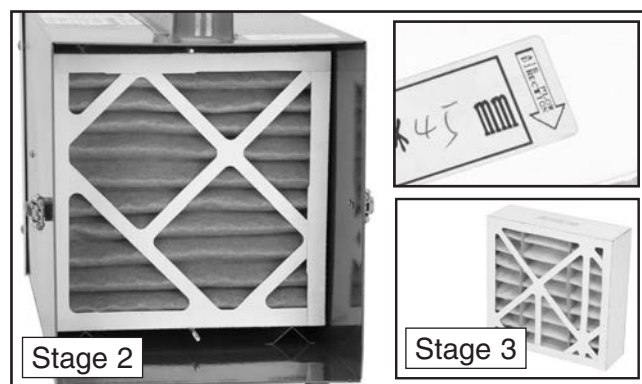

**Figure 22.** Consumable filters.

5. Reassemble the fume extractor and test it for improved suction. If the suction has only slightly improved, you must clean or replace one or both of the serviceable filters next.



# Serviceable Filter Cleaning

Stage 4 (Model T20638) and stage 5 (Model T20639) pleated filters can be removed and manually cleaned multiple times before replacement is required. However, doing so can slightly reduce lifespan and filtering ability. We recommend cleaning these filters only if the CFM is still poor after replacing the consumable filters.

Tools Needed	Qty
OSHA Approved Respirator .....	1
Safety Goggles.....	1
Air Compressor .....	1
Blowgun.....	1
Shop Vacuum w/HEPA Filter .....	1

## To perform this procedure:

1. UNPLUG THE MACHINE!
2. Put on your respirator and goggles, unlatch the access cover, and remove it.
3. Remove the two wing nuts, filter retainers, and the stainless steel screen (**Figure 21**).
4. Remove stage 2 and 3 filters (replace if required).
5. Remove stage 4 and 5 filters (**Figure 23**).

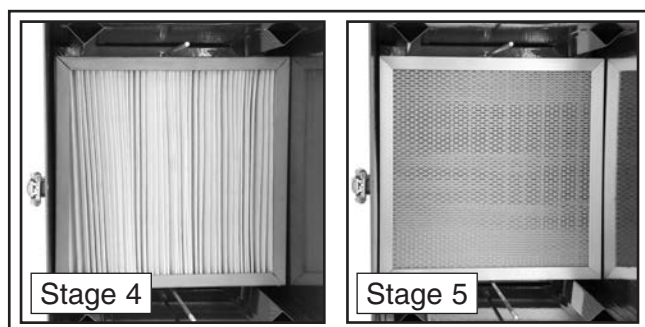

**Figure 23.** Stage 4 and 5 filters.

6. Inspect rubber seals for leaking and replace as required.
7. Support the filter element and vacuum the input side of the filter with a soft brush-type tip while ruffling the output side pleats with a soft rag or cardboard flap.
8. Hold a shop air gun or spray nozzle approximately two to three feet from the filter element. DO NOT position the blowgun tip too close to the filter, or the jet of air will tear the micro fibers or blow a hole in the filter.
9. While tapping the filter on a workbench, and in a slow and sweeping motion, blow the remaining contaminants back out the direction they came (against the direction of the printed arrow).
10. When no more dust can be blown out of the filters, set them aside, then wipe out the inside of the cabinet (**Figure 24**).

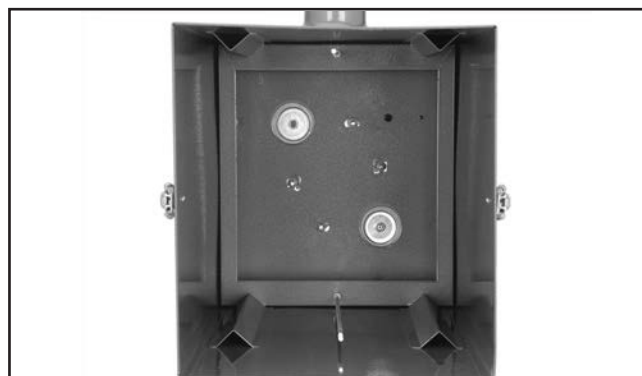

**Figure 24.** Empty cleaned cabinet.

11. Reinstall the filters to their appropriate locations in the cabinet, and reinstall the screen and access cover.



# SECTION 7: SERVICE

Review the troubleshooting and procedures in this section to fix or adjust your machine if a problem develops. If you need replacement parts or you are unsure of your repair skills, then feel free to call our Technical Support at (570) 546-9663.

## Troubleshooting

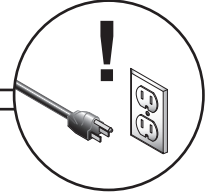

### Motors and Electrical

Symptom	Possible Cause	Possible Solution
Machine won't start circuit breaker trips.	<ol style="list-style-type: none"> <li>1. Damaged power cord.</li> <li>2. ON/OFF switch at fault.</li> <li>3. Circuit breaker/fuse has tripped.</li> <li>4. Wiring at fault.</li> <li>5. Motor at fault.</li> </ol>	<ol style="list-style-type: none"> <li>1. Test and replace power cord.</li> <li>2. Test and replace open switch.</li> <li>3. Have electrician correct for short, replace motor brushes, and reset circuit breaker.</li> <li>4. Repair for open or shorted wiring connections.</li> <li>5. Test and replace motor as required.</li> </ol>
Loss in CFM.	<ol style="list-style-type: none"> <li>1. Ducting system is at fault.</li> <li>2. Filters are at fault.</li> <li>3. Electrical system is at fault.</li> <li>4. Motor is at fault.</li> <li>5. Fan is at fault.</li> </ol>	<ol style="list-style-type: none"> <li>1. Inspect and eliminate kinks, or clogs in suction hood system. Do not exceed 20-foot long ducting.</li> <li>2. Service/replace filters and screen as required.</li> <li>3. Trace down wiring path and repair for damaged wiring or loose plugs, make sure both motors are operating.</li> <li>4. Replace brushes for slow running motor.</li> <li>5. Tighten or replace for slipping fan.</li> </ol>
Red warning lamp illuminates.	<ol style="list-style-type: none"> <li>1. Filters or screen need to be addressed.</li> </ol>	<ol style="list-style-type: none"> <li>1. Service/replace filters and screen as required.</li> </ol>
Machine vibrates.	<ol style="list-style-type: none"> <li>1. Mounting surface is uneven.</li> <li>2. Motor is at fault.</li> <li>3. Fan is at fault.</li> </ol>	<ol style="list-style-type: none"> <li>1. Adjust workbench feet or reposition workbench.</li> <li>2. Re-secure loose motor, or replace motor for bad bearings.</li> <li>3. Re-secure loose fan, or replace motor.</li> </ol>



# Motor Brush Replacement

During the life of your fume extractor, you may find it necessary to replace the motor brushes.

Tools Needed	Qty
Phillips Screwdriver #2 .....	1
Acetone and Cotton Rag.....	1
Crocus Cloth (From Local Auto Parts Store) ....	1
Brush Set.....	1

## To replace the brushes:

1. UNPLUG THE MACHINE!
2. Remove the eight motor cover screws and the cover (**Figure 25**).



Figure 25. Motor cover.

3. Remove the brush housing retaining screws and the brush assembly (**Figure 26**).

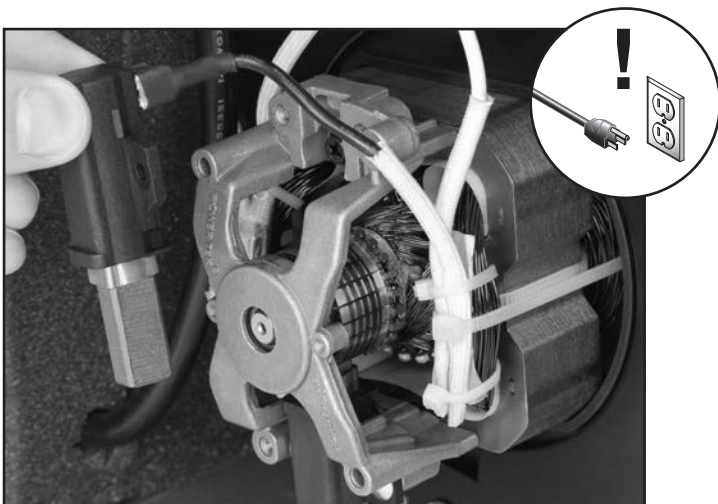

Figure 26. Brush removal.

4. Inspect the commutator surface (**Figure 27**).

—If the brushes have worn deep grooves in the commutator, we recommend replacing the motor. Typically the labor involved with re-turning the commutator on a lathe and then undercutting the insulator segments far exceeds the price of a new motor.

—If the commutator only has minor wear and black-colored carbon tracking (**Figure 27**), use a fine crocus cloth to polish the commutator where the brushes ride.

Finish the cleaning process by using acetone and a cotton rag to wipe off any oils or contaminants from the commutator. DO NOT use emery cloth or sandpaper to clean the commutator or you will make it out-of-round, which will cause the new brushes to arc, overheat, and wear out quickly.

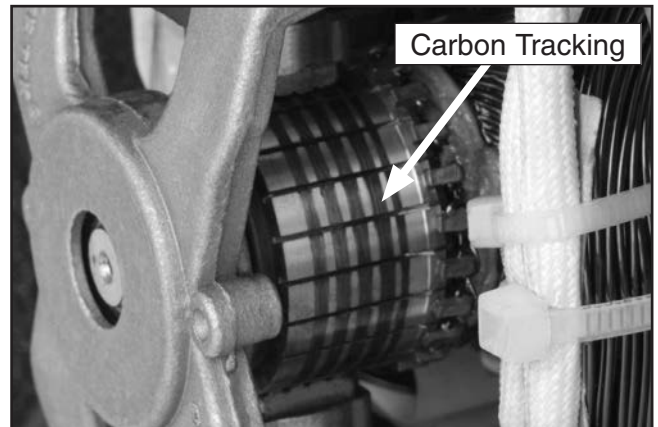

Figure 27. Commutator.

5. Replace the brush assembly and reinstall the screws and wire.
6. Reinstall the motor cover.



# Wiring Diagram

**Grizzly**  
Industrial, Inc.®

View this page in color at [www.grizzly.com](http://www.grizzly.com).



**WARNING!**  
**SHOCK HAZARD!**  
Disconnect power before working on wiring.



**COLOR KEY**

BLACK	—(Bk)—
WHITE	—(Wt)—
GREEN	—(Gn)—
RED	—(Rd)—

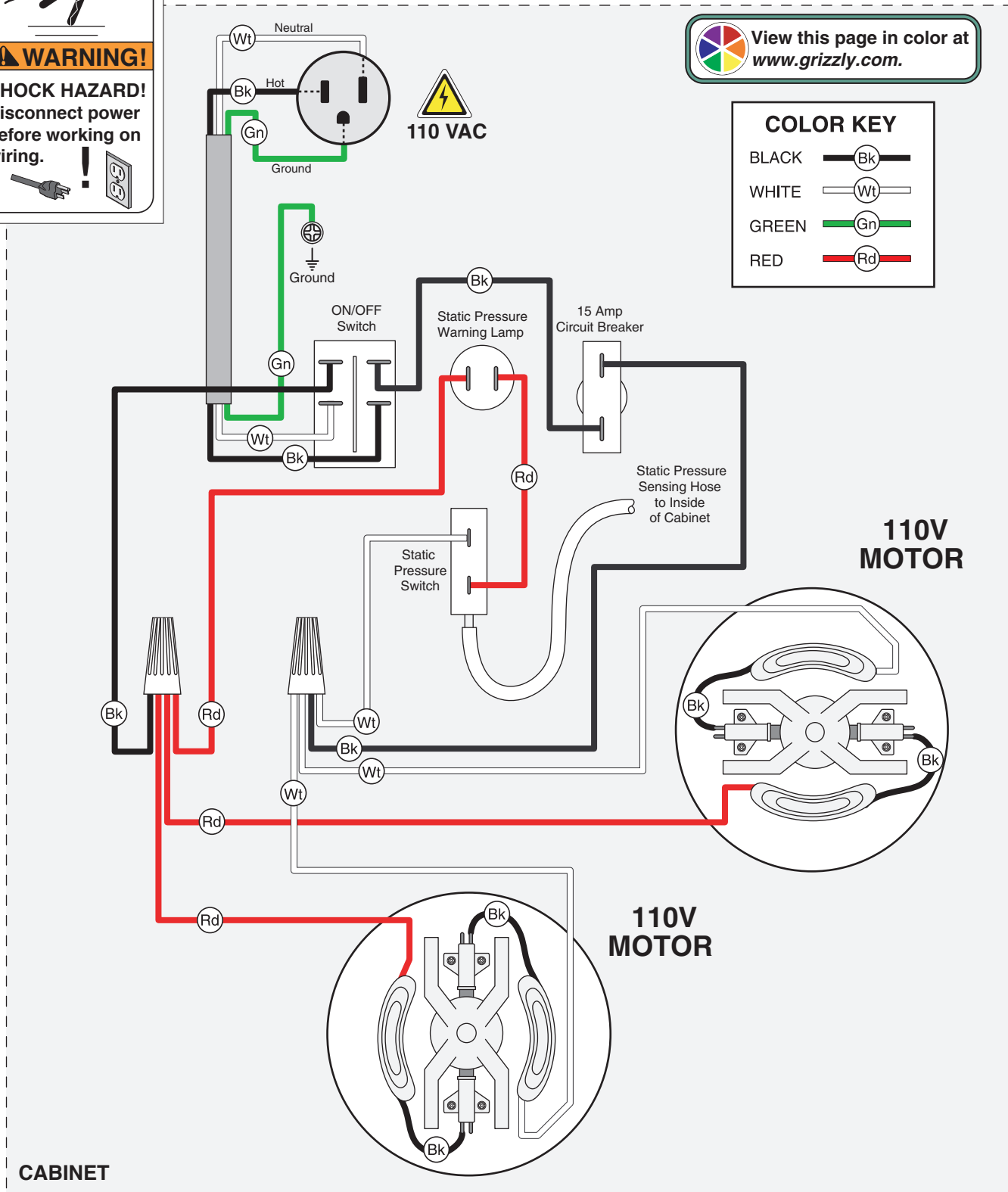

# Electrical Components

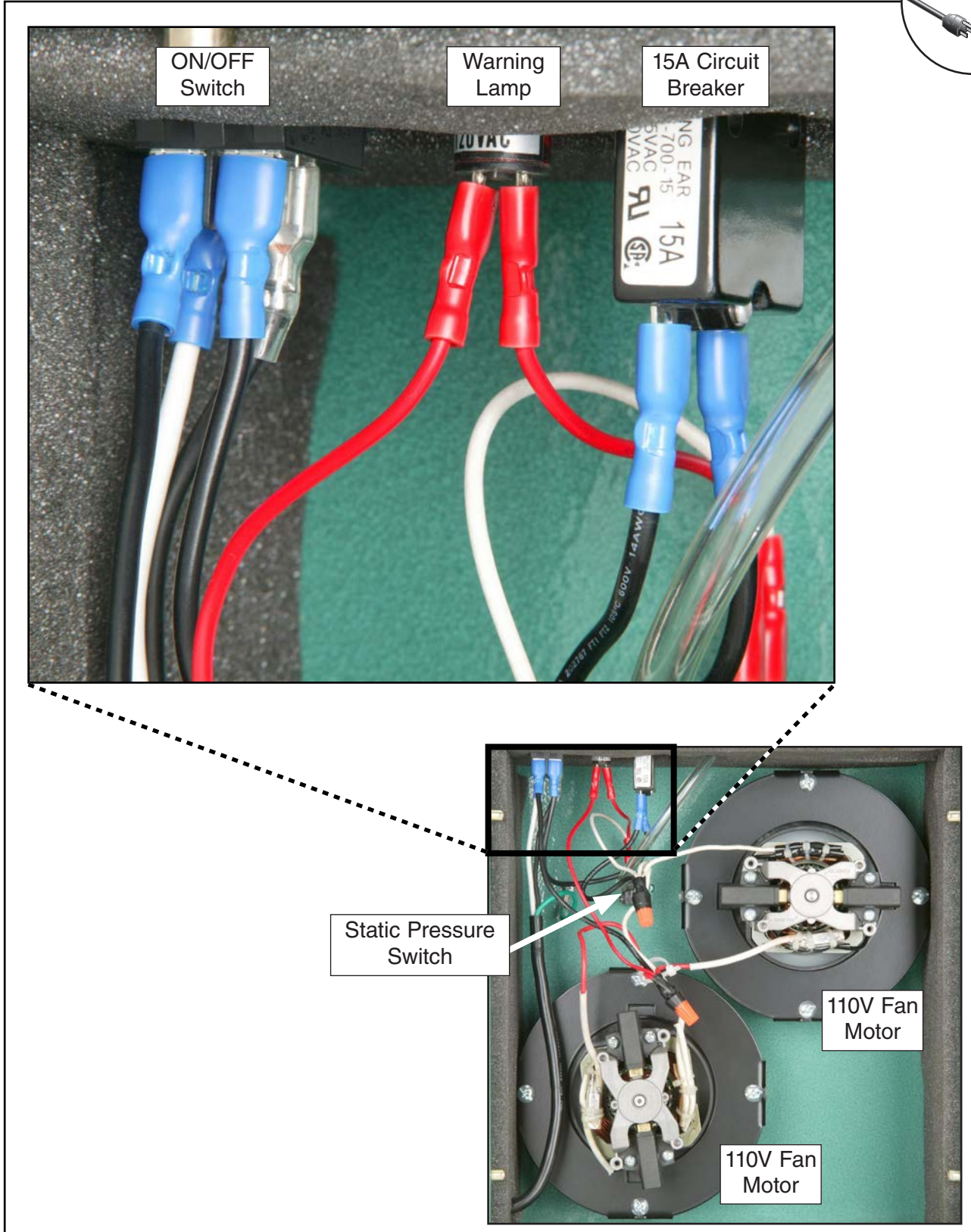
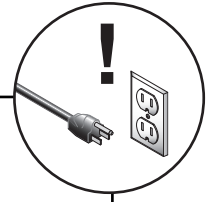
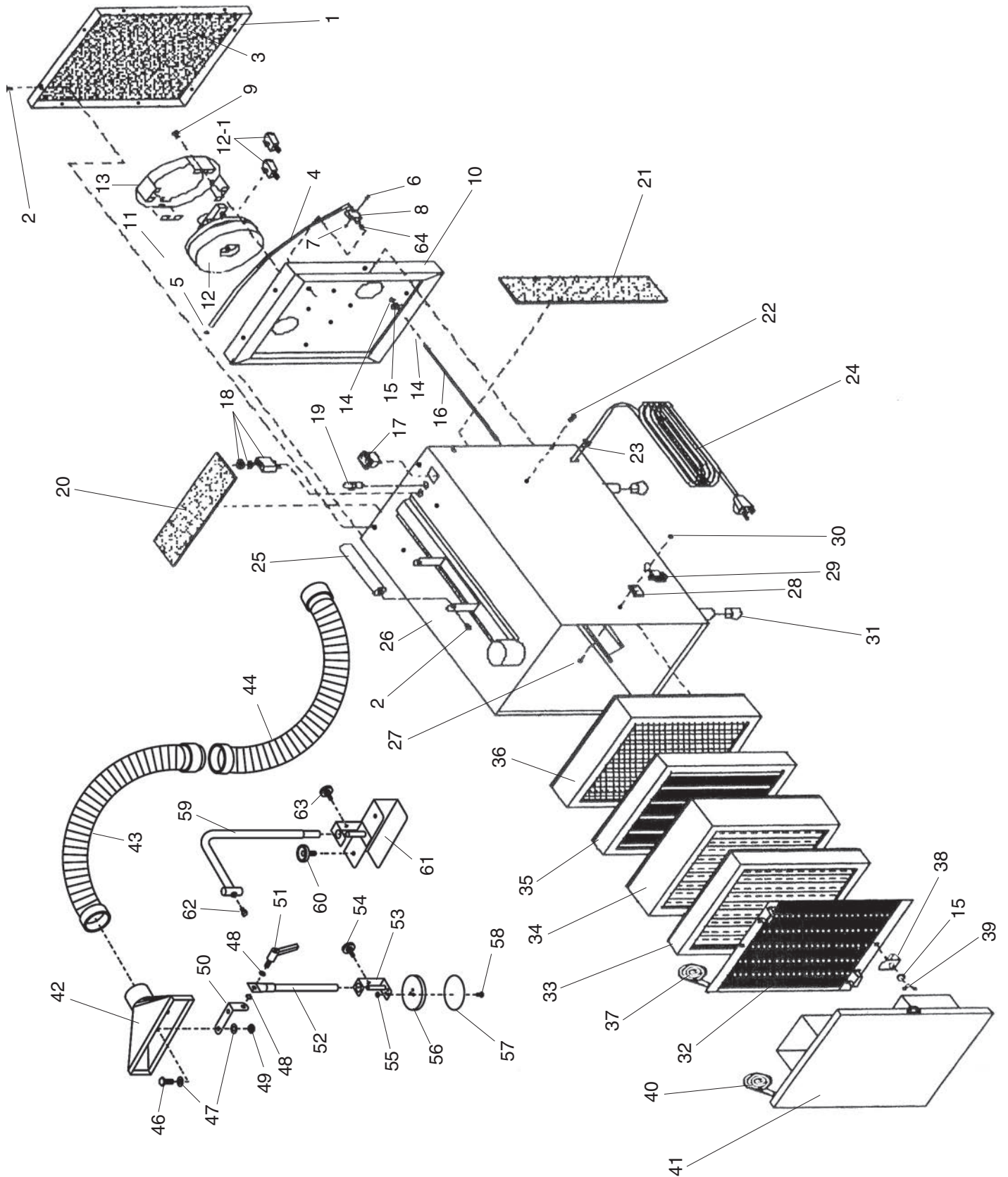

Figure 28. Electrical components.



# Parts Breakdown



# Parts List

REF	PART #	DESCRIPTION
1	PH8375001	MOTOR COVER
2	PS02	PHLP HD SCR 1/4-20 X 3/4
3	PH8375003	FOAM (10 X 315 X 350MM)
4	PH8375004	PLASTIC TUBING (5 X 7 X 650MM)
5	PH8375005	BULKHEAD HOSE FITTING
6	PH8375006	CAP SCREW M2-.4 X 20
7	PH8375007	INSULATOR NUT M2-.7
8	PH8375008	PRESSURE SWITCH (0~2" H2O)
9	PS15	PHLP HD SCR 1/4-20 X 2
10	PH8375010	MOTOR/FAN MOUNT
11	PH8375011	FOAM TAPE (3 X 6 X 455MM)
12	PH8375012	110V MOTOR W/FAN
12-1	PH8375012-1	MOTOR BRUSH SET
13	PH8375013	MOTOR MOUNTING BASE
14	PN05	HEX NUT 1/4-20
15	PW06	FLAT WASHER 1/4
16	PH8375016	FILTER ANCHOR ROD
17	PH8375017	SEALED POWER SWITCH
18	PH8375018	15A CIRCUIT BREAKER ASSEMBLY
19	PH8375019	RED INDICATOR LAMP ASSEMBLY
20	PH8375020	FOAM (10 X 120 X 305MM)
21	PH8375021	FOAM (10 X 120 X 340MM)
22	PS22	PHLP HD SCR 10-24 X 5/8
23	PH8375023	STRAIN RELIEF
24	PH8375024	110V POWER CORD 9'
25	PH8375025	HANDLE
26	PH8375026	CABINET
27	PFH51M	FLAT HD SCR M3-.5 X 10
28	PH8375028	SPACER
29	PH8375029	LATCH ASSEMBLY
30	PN07M	HEX NUT M3-.5
31	PH8375031	RUBBER FOOT

REF	PART #	DESCRIPTION
32	T20635	STAINLESS SCREEN (1-2MM)
33	T20636	PLEATED FILTER (2-10 MICRON)
34	T20637	PLEATED FILTER (1-2 MICRON)
35	T20638	PLEATED FILTER (1 MICRON)
36	T20639	HEPA FILTER (0.3 MICRON)
37	PH8375037	FOAM TAPE (3 X 6 X 1300MM)
38	PH8375038	L-BRACKET
39	PWN02	WING NUT 1/4-20
40	PH8375040	FOAM TAPE (3 X 6 X 1360MM)
41	PH8375041	FRONT COVER
42	PH8375042	SUCTION HOOD
43	PH8375043	2" DIA. FIREPROOF HOSE
44	PH8375044	2.5" DIA. PVC HOSE
46	PB07	HEX BOLT 5/16-18 X 3/4
47	PW07	FLAT WASHER 5/16
48	PLW01	LOCK WASHER 5/16
49	PN02	HEX NUT 5/16-18
50	PH8375050	L-BRACKET
51	PH8375051	LEVER
52	PH8375052	ROD
53	PH8375053	BASE BRACKET
54	PH8375054	LOCK KNOB
55	PN07	HEX NUT 10-24
56	PH8375056	MAGNETIC BASE
57	PH8375057	ANTI-SCUFF DISK
58	PS06	PHLP HD SCR 10-24 x 3/8
59	PH8375059	EXTENSION ARM
60	PH8375060	HAND KNOB
61	PH8375061	CLAMP BODY
62	PH8375062	LARGE THUMB SCREW KNOB
63	PH8375063	SMALL THUMB SCREW KNOB
64	PH8375064	PRESSURE SWITCH SUPPORT RING



# Label Placement

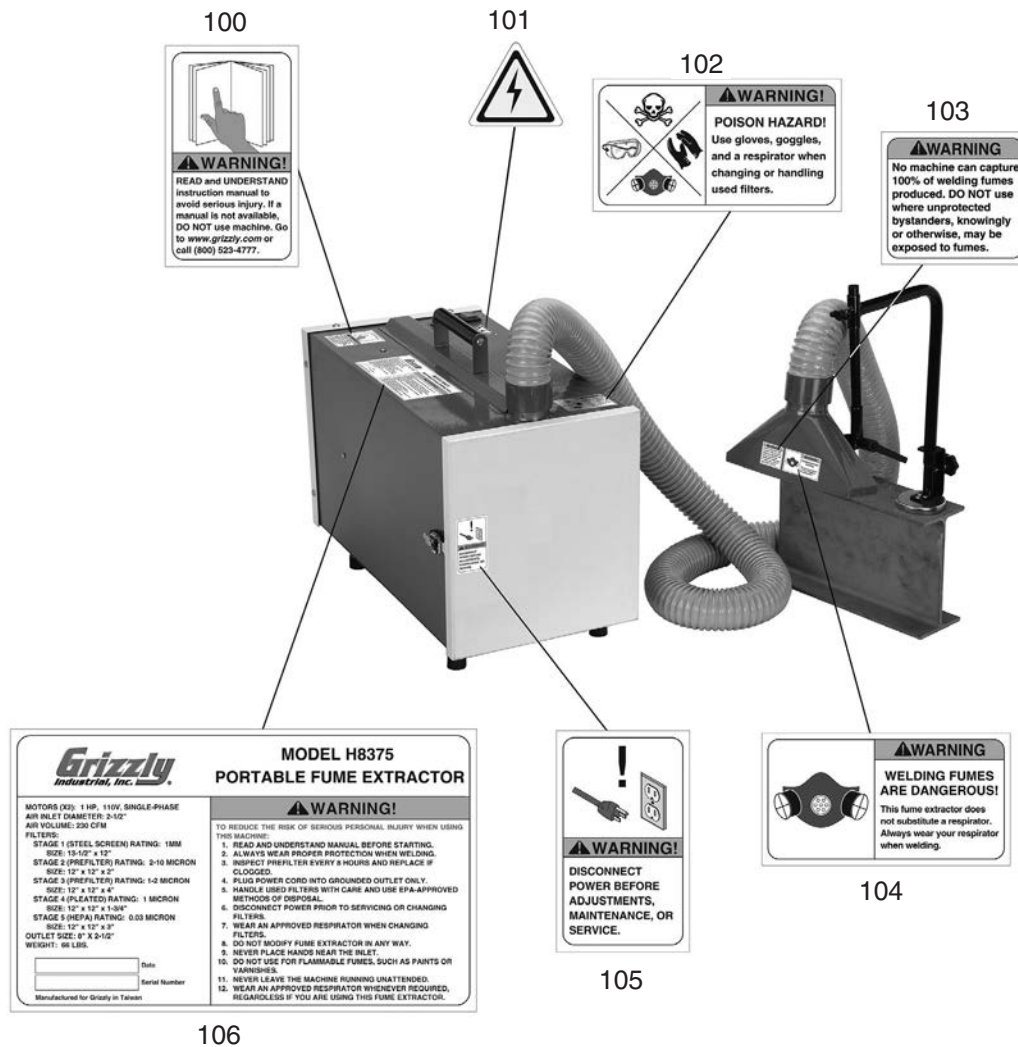

REF	PART #	DESCRIPTION
100	PLABEL-12A	READ MANUAL LABEL
101	PLABEL-14	ELECTRICITY LABEL
102	PH8375102	POISON HAZARD LABEL
103	PH8375103	GENERAL FUMES LABEL

REF	PART #	DESCRIPTION
104	PH8375104	WELDING RESPIRATOR LABEL
105	PLABEL-26	UNPLUG 110V 2" X 3 5/16"
106	PH8375106	DATA LABEL

**⚠ WARNING**

Safety labels warn about machine hazards and ways to prevent injury. The owner of this machine **MUST** maintain the original location and readability of the labels on the machine. If any label is removed or becomes unreadable, **REPLACE** that label before using the machine again. Contact Grizzly at (800) 523-4777 or [www.grizzly.com](http://www.grizzly.com) to order new labels.





# WARRANTY CARD

Name \_\_\_\_\_  
 Street \_\_\_\_\_  
 City \_\_\_\_\_ State \_\_\_\_\_ Zip \_\_\_\_\_  
 Phone # \_\_\_\_\_ Email \_\_\_\_\_  
 Model # \_\_\_\_\_ Order # \_\_\_\_\_ Serial # \_\_\_\_\_

The following information is given on a voluntary basis. It will be used for marketing purposes to help us develop better products and services. **Of course, all information is strictly confidential.**

- How did you learn about us?
 

<input type="checkbox"/> Advertisement	<input type="checkbox"/> Friend	<input type="checkbox"/> Catalog
<input type="checkbox"/> Card Deck	<input type="checkbox"/> Website	<input type="checkbox"/> Other:
- Which of the following magazines do you subscribe to?
 

<input type="checkbox"/> Cabinetmaker & FDM	<input type="checkbox"/> Popular Science	<input type="checkbox"/> Wooden Boat
<input type="checkbox"/> Family Handyman	<input type="checkbox"/> Popular Woodworking	<input type="checkbox"/> Woodshop News
<input type="checkbox"/> Hand Loader	<input type="checkbox"/> Precision Shooter	<input type="checkbox"/> Woodsmith
<input type="checkbox"/> Handy	<input type="checkbox"/> Projects in Metal	<input type="checkbox"/> Woodwork
<input type="checkbox"/> Home Shop Machinist	<input type="checkbox"/> RC Modeler	<input type="checkbox"/> Woodworker West
<input type="checkbox"/> Journal of Light Cont.	<input type="checkbox"/> Rifle	<input type="checkbox"/> Woodworker's Journal
<input type="checkbox"/> Live Steam	<input type="checkbox"/> Shop Notes	<input type="checkbox"/> Other:
<input type="checkbox"/> Model Airplane News	<input type="checkbox"/> Shotgun News	
<input type="checkbox"/> Old House Journal	<input type="checkbox"/> Today's Homeowner	
<input type="checkbox"/> Popular Mechanics	<input type="checkbox"/> Wood	
- What is your annual household income?
 

<input type="checkbox"/> \$20,000-\$29,000	<input type="checkbox"/> \$30,000-\$39,000	<input type="checkbox"/> \$40,000-\$49,000
<input type="checkbox"/> \$50,000-\$59,000	<input type="checkbox"/> \$60,000-\$69,000	<input type="checkbox"/> \$70,000+
- What is your age group?
 

<input type="checkbox"/> 20-29	<input type="checkbox"/> 30-39	<input type="checkbox"/> 40-49
<input type="checkbox"/> 50-59	<input type="checkbox"/> 60-69	<input type="checkbox"/> 70+
- How long have you been a woodworker/metalworker?
 

<input type="checkbox"/> 0-2 Years	<input type="checkbox"/> 2-8 Years	<input type="checkbox"/> 8-20 Years	<input type="checkbox"/> 20+ Years
------------------------------------	------------------------------------	-------------------------------------	------------------------------------
- How many of your machines or tools are Grizzly?
 

<input type="checkbox"/> 0-2	<input type="checkbox"/> 3-5	<input type="checkbox"/> 6-9	<input type="checkbox"/> 10+
------------------------------	------------------------------	------------------------------	------------------------------
- Do you think your machine represents a good value?  Yes  No
- Would you recommend Grizzly Industrial to a friend?  Yes  No
- Would you allow us to use your name as a reference for Grizzly customers in your area?  
**Note: We never use names more than 3 times.**  Yes  No

10. Comments: \_\_\_\_\_  
 \_\_\_\_\_  
 \_\_\_\_\_  
 \_\_\_\_\_

CUT ALONG DOTTED LINE

FOLD ALONG DOTTED LINE

\_\_\_\_\_
\_\_\_\_\_
\_\_\_\_\_



Place Stamp Here



GRIZZLY INDUSTRIAL, INC.
P.O. BOX 2069
BELLINGHAM, WA 98227-2069



FOLD ALONG DOTTED LINE

Send a Grizzly Catalog to a friend:

Name \_\_\_\_\_
Street \_\_\_\_\_
City \_\_\_\_\_ State \_\_\_\_\_ Zip \_\_\_\_\_

TAPE ALONG EDGES--PLEASE DO NOT STAPLE

# WARRANTY AND RETURNS

---

Grizzly Industrial, Inc. warrants every product it sells for a period of **1 year** to the original purchaser from the date of purchase. This warranty does not apply to defects due directly or indirectly to misuse, abuse, negligence, accidents, repairs or alterations or lack of maintenance. This is Grizzly's sole written warranty and any and all warranties that may be implied by law, including any merchantability or fitness, for any particular purpose, are hereby limited to the duration of this written warranty. We do not warrant or represent that the merchandise complies with the provisions of any law or acts unless the manufacturer so warrants. In no event shall Grizzly's liability under this warranty exceed the purchase price paid for the product and any legal actions brought against Grizzly shall be tried in the State of Washington, County of Whatcom.

We shall in no event be liable for death, injuries to persons or property or for incidental, contingent, special, or consequential damages arising from the use of our products.

To take advantage of this warranty, contact us by mail or phone and give us all the details. We will then issue you a "Return Number," which must be clearly posted on the outside as well as the inside of the carton. We will not accept any item back without this number. Proof of purchase must accompany the merchandise.

The manufacturers reserve the right to change specifications at any time because they constantly strive to achieve better quality equipment. We make every effort to ensure that our products meet high quality and durability standards and we hope you never need to use this warranty.

Please feel free to write or call us if you have any questions about the machine or the manual.

Thank you again for your business and continued support. We hope to serve you again soon.

***grizzly.com***®  
**TOOL WEBSITE**

Buy Direct and Save with Grizzly® – Trusted, Proven and a Great Value!  
~Since 1983~

*Visit Our Website Today For  
Current Specials!*

**ORDER  
24 HOURS A DAY!  
1-800-523-4777**

