

# ***Grizzly*** ***Industrial, Inc.***®

## **MODEL H8172 CEMENT MIXER OWNER'S MANUAL**

*(For models manufactured since 10/14)*



COPYRIGHT © APRIL, 2007 BY GRIZZLY INDUSTRIAL, INC., REVISED NOVEMBER, 2014 (AW)

**WARNING: NO PORTION OF THIS MANUAL MAY BE REPRODUCED IN ANY SHAPE  
OR FORM WITHOUT THE WRITTEN APPROVAL OF GRIZZLY INDUSTRIAL, INC.**

#TR9030 PRINTED IN CHINA

V2.11.14



## **WARNING!**

**This manual provides critical safety instructions on the proper setup, operation, maintenance, and service of this machine/tool. Save this document, refer to it often, and use it to instruct other operators.**

**Failure to read, understand and follow the instructions in this manual may result in fire or serious personal injury—including amputation, electrocution, or death.**

**The owner of this machine/tool is solely responsible for its safe use. This responsibility includes but is not limited to proper installation in a safe environment, personnel training and usage authorization, proper inspection and maintenance, manual availability and comprehension, application of safety devices, cutting/sanding/grinding tool integrity, and the usage of personal protective equipment.**

**The manufacturer will not be held liable for injury or property damage from negligence, improper training, machine modifications or misuse.**



## **WARNING!**

**Some dust created by power sanding, sawing, grinding, drilling, and other construction activities contains chemicals known to the State of California to cause cancer, birth defects or other reproductive harm. Some examples of these chemicals are:**

- **Lead from lead-based paints.**
- **Crystalline silica from bricks, cement and other masonry products.**
- **Arsenic and chromium from chemically-treated lumber.**

**Your risk from these exposures varies, depending on how often you do this type of work. To reduce your exposure to these chemicals: Work in a well ventilated area, and work with approved safety equipment, such as those dust masks that are specially designed to filter out microscopic particles.**

# Table of Contents

<b>INTRODUCTION</b> .....	<b>2</b>
Manual Accuracy .....	2
Contact Info .....	2
<b>SECTION 1: SAFETY</b> .....	<b>4</b>
Safety Instructions for Machinery .....	4
Additional Safety for Cement Mixers .....	6
<b>SECTION 2: POWER SUPPLY</b> .....	<b>7</b>
<b>SECTION 3: SETUP</b> .....	<b>9</b>
Unpacking .....	9
Needed for Setup .....	9
Inventory .....	10
Assembly .....	11
Test Run .....	14
<b>SECTION 4: OPERATIONS</b> .....	<b>15</b>
Operation Safety .....	15
Operation Tips .....	15
<b>SECTION 5: ACCESSORIES</b> .....	<b>16</b>
<b>SECTION 5: MAINTENANCE</b> .....	<b>17</b>
Lubrication .....	17
Cleaning .....	17
Drive Belt .....	17
<b>SECTION 6: WIRING</b> .....	<b>18</b>
Wiring Safety Instructions .....	18
Wiring Diagram .....	19
<b>SECTION 7: PARTS</b> .....	<b>20</b>
Main Breakdown .....	20
Main Parts List .....	21
Labels & Cosmetics .....	22
<b>WARRANTY &amp; RETURNS</b> .....	<b>25</b>

# INTRODUCTION

---

---

## Manual Accuracy

---

---

We are proud to provide a high-quality owner's manual with your new machine!

We made every effort to be exact with the instructions, specifications, drawings, and photographs contained inside. Sometimes we make mistakes, but our policy of continuous improvement also means that **sometimes the machine you receive will be slightly different than what is shown in the manual.**

If you find this to be the case, and the difference between the manual and machine leaves you confused about a procedure, check our website for an updated version. We post current manuals and manual updates for free on our website at **[www.grizzly.com](http://www.grizzly.com)**.

## Contact Info

---

---

We stand behind our machines. If you have any questions or need help, use the information below to contact us. Before contacting, please get the serial number and manufacture date of your machine. This will help us help you faster.

Grizzly Technical Support  
1203 Lycoming Mall Circle  
Muncy, PA 17756  
Phone: (570) 546-9663  
Email: [techsupport@grizzly.com](mailto:techsupport@grizzly.com)

We want your feedback on this manual. What did you like about it? Where could it be improved? Please take a few minutes to give us feedback.

Grizzly Documentation Manager  
P.O. Box 2069  
Bellingham, WA 98227-2069  
Email: [manuals@grizzly.com](mailto:manuals@grizzly.com)





# MACHINE DATA SHEET

Customer Service #: (570) 546-9663 • To Order Call: (800) 523-4777 • Fax #: (800) 438-5901

## MODEL H8172 CEMENT MIXER

### Product Dimensions:

Weight ..... 132 lbs.  
Length/Width/Height ..... 50" x 33" x 54"

### Shipping Dimensions:

Weight ..... 145 lbs.  
Length/Width/Height ..... 31" x 38" x 21"

### Motor:

Horsepower..... 1 HP  
Voltage..... 110V  
Amps..... 8A  
Speed..... 3450 RPM  
Cycle..... 60 Hz

### Main Specifications:

Drum Rotation Speed ..... 35 RPM  
Total Drum Capacity ..... 6.36 Cubic Feet or Approximately ¼ Cubic Yard  
Maximum Recommended Capacity ..... 3.2 Cubic Feet or ⅓ Cubic Yard (Six 60 lb. Bags or Four 90 lb. Bags)



# SECTION 1: SAFETY

## For Your Own Safety, Read Instruction Manual Before Operating This Machine

The purpose of safety symbols is to attract your attention to possible hazardous conditions. This manual uses a series of symbols and signal words intended to convey the level of importance of the safety messages. The progression of symbols is described below. Remember that safety messages by themselves do not eliminate danger and are not a substitute for proper accident prevention measures. Always use common sense and good judgment.

 **DANGER** Indicates an imminently hazardous situation which, if not avoided, **WILL** result in death or serious injury.

 **WARNING** Indicates a potentially hazardous situation which, if not avoided, **COULD** result in death or serious injury.

 **CAUTION** Indicates a potentially hazardous situation which, if not avoided, **MAY** result in minor or moderate injury. It may also be used to alert against unsafe practices.

**NOTICE** This symbol is used to alert the user to useful information about proper operation of the machine.

## Safety Instructions for Machinery

### **WARNING**

**OWNER'S MANUAL.** Read and understand this owner's manual **BEFORE** using machine.

**TRAINED OPERATORS ONLY.** Untrained operators have a higher risk of being hurt or killed. Only allow trained/supervised people to use this machine. When machine is not being used, disconnect power, remove switch keys, or lock-out machine to prevent unauthorized use—especially around children. Make workshop kid proof!

**DANGEROUS ENVIRONMENTS.** Do not use machinery in areas that are wet, cluttered, or have poor lighting. Operating machinery in these areas greatly increases the risk of accidents and injury.

**MENTAL ALERTNESS REQUIRED.** Full mental alertness is required for safe operation of machinery. Never operate under the influence of drugs or alcohol, when tired, or when distracted.

**ELECTRICAL EQUIPMENT INJURY RISKS.** You can be shocked, burned, or killed by touching live electrical components or improperly grounded machinery. To reduce this risk, only allow qualified service personnel to do electrical installation or repair work, and always disconnect power before accessing or exposing electrical equipment.

**DISCONNECT POWER FIRST.** Always disconnect machine from power supply **BEFORE** making adjustments, changing tooling, or servicing machine. This prevents an injury risk from unintended startup or contact with live electrical components.

**EYE PROTECTION.** Always wear ANSI-approved safety glasses or a face shield when operating or observing machinery to reduce the risk of eye injury or blindness from flying particles. Everyday eyeglasses are **NOT** approved safety glasses.



# WARNING

**WEARING PROPER APPAREL.** Do not wear clothing, apparel or jewelry that can become entangled in moving parts. Always tie back or cover long hair. Wear non-slip footwear to avoid accidental slips, which could cause loss of workpiece control.

**HAZARDOUS DUST.** Dust created while using machinery may cause cancer, birth defects, or long-term respiratory damage. Be aware of dust hazards associated with each workpiece material, and always wear a NIOSH-approved respirator to reduce your risk.

**HEARING PROTECTION.** Always wear hearing protection when operating or observing loud machinery. Extended exposure to this noise without hearing protection can cause permanent hearing loss.

**REMOVE ADJUSTING TOOLS.** Tools left on machinery can become dangerous projectiles upon startup. Never leave chuck keys, wrenches, or any other tools on machine. Always verify removal before starting!

**USE CORRECT TOOL FOR THE JOB.** Only use this tool for its intended purpose—do not force it or an attachment to do a job for which it was not designed. Never make unapproved modifications—modifying tool or using it differently than intended may result in malfunction or mechanical failure that can lead to personal injury or death!

**AWKWARD POSITIONS.** Keep proper footing and balance at all times when operating machine. Do not overreach! Avoid awkward hand positions that make workpiece control difficult or increase the risk of accidental injury.

**CHILDREN & BYSTANDERS.** Keep children and bystanders at a safe distance from the work area. Stop using machine if they become a distraction.

**GUARDS & COVERS.** Guards and covers reduce accidental contact with moving parts or flying debris. Make sure they are properly installed, undamaged, and working correctly.

**FORCING MACHINERY.** Do not force machine. It will do the job safer and better at the rate for which it was designed.

**NEVER STAND ON MACHINE.** Serious injury may occur if machine is tipped or if the cutting tool is unintentionally contacted.

**STABLE MACHINE.** Unexpected movement during operation greatly increases risk of injury or loss of control. Before starting, verify machine is stable and mobile base (if used) is locked.

**USE RECOMMENDED ACCESSORIES.** Consult this owner's manual or the manufacturer for recommended accessories. Using improper accessories will increase the risk of serious injury.

**UNATTENDED OPERATION.** To reduce the risk of accidental injury, turn machine **OFF** and ensure all moving parts completely stop before walking away. Never leave machine running while unattended.

**MAINTAIN WITH CARE.** Follow all maintenance instructions and lubrication schedules to keep machine in good working condition. A machine that is improperly maintained could malfunction, leading to serious personal injury or death.

**CHECK DAMAGED PARTS.** Regularly inspect machine for any condition that may affect safe operation. Immediately repair or replace damaged or mis-adjusted parts before operating machine.

**MAINTAIN POWER CORDS.** When disconnecting cord-connected machines from power, grab and pull the plug—NOT the cord. Pulling the cord may damage the wires inside. Do not handle cord/plug with wet hands. Avoid cord damage by keeping it away from heated surfaces, high traffic areas, harsh chemicals, and wet/damp locations.

**EXPERIENCING DIFFICULTIES.** If at any time you experience difficulties performing the intended operation, stop using the machine! Contact our Technical Support at (570) 546-9663.



# Additional Safety for Cement Mixers

## WARNING

**HAZARDOUS DUST.** All cement, mortar, grout, and silicate dusts are hazardous to respiratory systems. Protect yourself and any bystanders by always wearing a respirator approved to guard against these kinds of dusts.

**PINCH/CRUSHING HAZARD AREA.** The drum has a noticeable ring of gear teeth around the circumference. The area where these teeth meet the driving gear is a severe pinch hazard. Keep hands, fingers, and all body parts away from these gear teeth and the driving gear to avoid injury from this hazard. *DO NOT operate the mixer with the gear cover/guard removed!*

**CHILDREN.** Never allow children to play on, in, or with the cement mixer.

**STORAGE.** Store the cement mixer with the drum in the down position and disconnected from power to reduce the risk of children climbing inside and injuring themselves.

**ENTANGLEMENT.** The spinning drum and engaging gears present an entanglement hazard. When using the cement mixer, tie back long hair, roll up long sleeves, and remove loose clothing or jewelry to reduce the risk of an entanglement injury.

**SERVICE & ADJUSTMENTS.** Like all machines, this machine presents a risk of injury if it is serviced or adjusted while it is connected to power. Disconnect power before doing any service, maintenance, or adjustments to reduce the risk of accidental injury.

**WATER VS. ELECTRIC COMPONENTS.** The electric components are designed to resist accidental exposure to water, but they are not water-proof. Avoid intentionally getting the motor and switch wet to reduce the risk of shock or equipment damage. If the internal parts of these components do get wet, immediately disconnect power and allow the parts to completely dry before reconnecting the mixer to the power supply.

## WARNING

Like all machinery there is potential danger when operating this machine. Accidents are frequently caused by lack of familiarity or failure to pay attention. Use this machine with respect and caution to lessen the possibility of operator injury. If normal safety precautions are overlooked or ignored, serious personal injury may occur.

## CAUTION

No list of safety guidelines can be complete. Every shop environment is different. Always consider safety first, as it applies to your individual working conditions. Use this and other machinery with caution and respect. Failure to do so could result in serious personal injury, damage to equipment, or poor work results.



# SECTION 2: POWER SUPPLY

## Availability

Before installing the machine, consider the availability and proximity of the required power supply circuit. If an existing circuit does not meet the requirements for this machine, a new circuit must be installed. To minimize the risk of electrocution, fire, or equipment damage, installation work and electrical wiring must be done by an electrician or qualified service personnel in accordance with all applicable codes and standards.

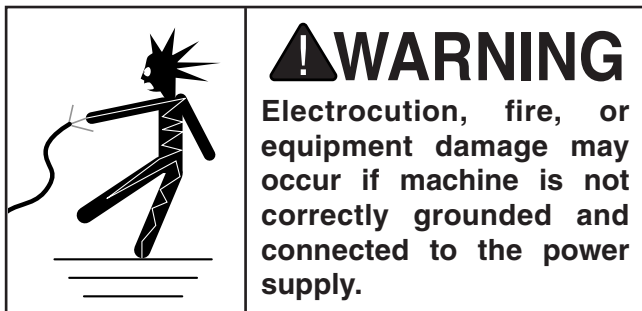

## Full-Load Current Rating

The full-load current rating is the amperage a machine draws at 100% of the rated output power. On machines with multiple motors, this is the amperage drawn by the largest motor or sum of all motors and electrical devices that might operate at one time during normal operations.

### Full-Load Current Rating at 110V..... 8 Amps

The full-load current is not the maximum amount of amps that the machine will draw. If the machine is overloaded, it will draw additional amps beyond the full-load rating.

If the machine is overloaded for a sufficient length of time, damage, overheating, or fire may result—especially if connected to an undersized circuit. To reduce the risk of these hazards, avoid overloading the machine during operation and make sure it is connected to a power supply circuit that meets the specified circuit requirements.

## **! WARNING**

**Serious injury could occur if you connect the machine to power before completing the setup process. DO NOT connect to power until instructed later in this manual.**

## 110V Circuit Requirements

This machine is prewired to operate on a power supply circuit that has a verified ground and meets the following requirements:

Nominal Voltage ..... 110V  
Cycle ..... 60 Hz  
Phase ..... Single-Phase  
Power Supply Circuit ..... 15 Amps

A power supply circuit includes all electrical equipment between the breaker box or fuse panel in the building and the machine. The power supply circuit used for this machine must be sized to safely handle the full-load current drawn from the machine for an extended period of time. (If this machine is connected to a circuit protected by fuses, use a time delay fuse marked D.)

## **! CAUTION**

**For your own safety and protection of property, consult an electrician if you are unsure about wiring practices or electrical codes in your area.**

**Note:** *Circuit requirements in this manual apply to a dedicated circuit—where only one machine will be running on the circuit at a time. If machine will be connected to a shared circuit where multiple machines may be running at the same time, consult an electrician or qualified service personnel to ensure circuit is properly sized for safe operation.*



## Polarized Plug

This tool is double-insulated and therefore does not have a grounding wire or plug. The two-pronged, NEMA 1-15 plug (see **Figure 1**) has a polarized end; this means that one prong (the neutral connector) is wider than the other (the hot connector). Polarized plugs must be used only with polarized receptacles. Do not attempt to plug this machine into a non-polarized receptacle. If a polarized receptacle is not available, a qualified electrical technician will have to install one before the machine can be plugged in.

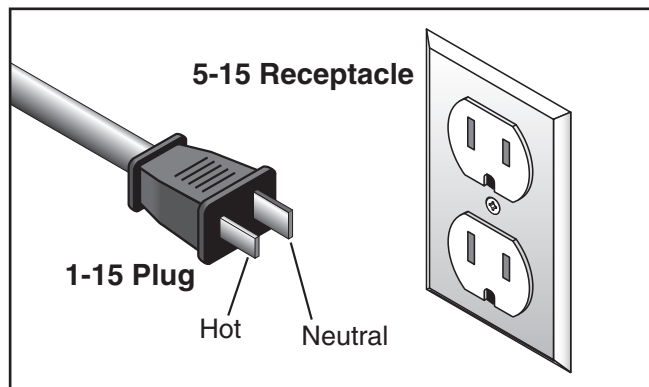

**Figure 1.** Typical 1-15 plug and receptacle.

## Extension Cords

When using extension cords, make sure the cords are rated for outdoor use. Outdoor use cords are marked with a "W-A" or a "W" to signify their rating. Always check to make sure that the extension cords are in good working order and free of any type of damage, such as exposed wires, cuts, creased bends, or missing prongs.

Extension cords cause voltage drop, which may damage electrical components and shorten motor life. Voltage drop increases as the extension cord size gets longer and the gauge size gets smaller (higher gauge numbers indicate smaller sizes. When using extension cords, always choose the shortest cord possible, with the greatest-sized gauge.

Below is a list of minimum gauge sizes needed for running this tool at different lengths:

<b>25 Feet</b> .....	<b>16 AWG</b>
<b>50 Feet</b> .....	<b>14 AWG</b>
<b>100 Feet</b> .....	<b>12 AWG</b>
<b>Over 100 Feet</b> .....	<b>Not Recommended</b>



# SECTION 3: SETUP

## Unpacking

Your machine was carefully packaged for safe transportation. Remove the packaging materials from around your machine and inspect it. If you discover any damage, *please call us immediately at (570) 546-9663 for advice.*

Save the containers and all packing materials for possible inspection by the carrier or its agent. *Otherwise, filing a freight claim can be difficult.*

When you are completely satisfied with the condition of your shipment, inventory the contents.

	<p><b>⚠️ WARNING</b> <b>SUFFOCATION HAZARD!</b> Keep children and pets away from plastic bags or packing materials shipped with this machine. Discard immediately.</p>
--	--

## Needed for Setup

The following are needed to complete the setup process, but are not included with your machine.

Description	Qty
• Additional People .....	1
• Safety Glasses .....	1 Per Person
• Cleaner/Degreaser .....	As Needed
• Disposable Shop Rags.....	As Needed
• Screwdriver Phillips #2.....	1
• Screwdriver Phillips #3.....	1
• Wrench/Socket 13mm .....	2
• Wrench/Socket 14mm .....	2
• Wrench/Socket 17mm .....	1



# Inventory

The following is a list of items shipped with your machine. Before beginning setup, lay these items out and inventory them.

If any non-proprietary parts are missing (e.g. a nut or a washer), we will gladly replace them; or for the sake of expediency, replacements can be obtained at your local hardware store.

Main Components (see Figures 2 & 3)	Qty
A. Lower Drum.....	1
B. Motor Assembly.....	1
C. Tipping Wheel .....	1
D. Upper Drum.....	1
E. Support Leg.....	1
F. Frame .....	1
G. Axle Bracket.....	1
H. Mixing Blades.....	2
I. Wheels .....	2
J. Bearing Block .....	1
K. Upper Bracket .....	1
L. Gasket (not shown).....	1

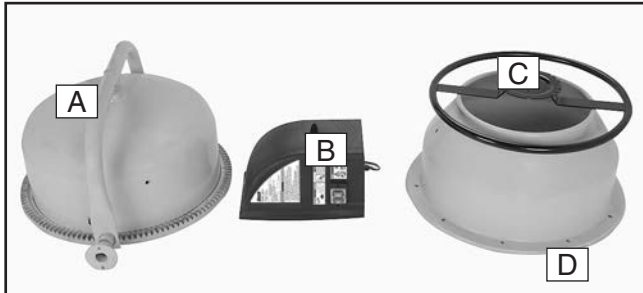

Figure 2. Inventory components (picture 1).

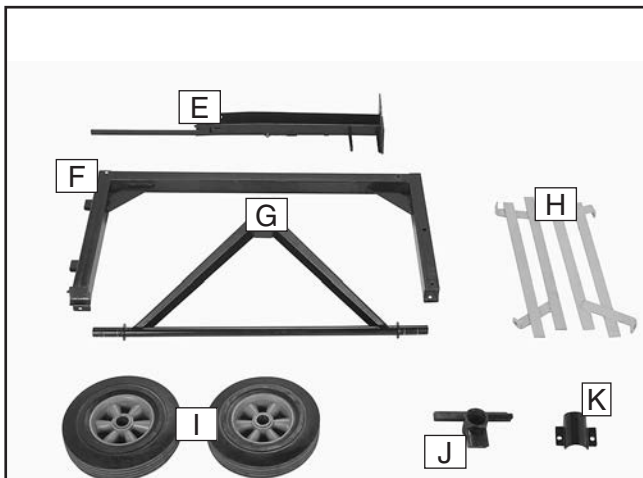

Figure 3. Inventory components (picture 2).

Hardware	Qty
Hairpin Cotter Pin (Wheels) .....	2
Hex Bolts M8-1.25 x 65 (Leg to Frame).....	2
Flat Washers 8mm (Leg to Frame) .....	2
Lock Washers 8mm (Leg to Frame) .....	2
Hex Nuts M8-1.25 (Leg to Frame) .....	2
Hex Bolt M6-1 x 25 (Plunger Rods) .....	1
Lock Nut M6-1 (Plunger Rods).....	1
Cotter Pin (Plunger Rod).....	1
Hex Bolts M8-1.25 x 65 (Bracket to Frame) ....	2
Flat Washers 8mm (Bracket to Frame).....	2
Lock Washers 8mm (Bracket to Frame) .....	2
Hex Nuts M8-1.25 (Bracket to Frame) .....	2
Hex Bolts M8-1.25 x 60 (Bearing Block).....	1
Flat Washers 8mm (Bearing Block) .....	1
Lock Washers 8mm (Bearing Block).....	1
Hex Nuts M8-1.25 (Bearing Block).....	1
Hex Bolts M8-1.25 x 20 (Upper Bracket) .....	2
Flat Washers 8mm (Upper Bracket).....	2
Lock Washers 8mm (Upper Bracket) .....	2
Hex Nuts M8-1.25 (Upper Bracket).....	2
Phillips Screws M10-1.5 x 20 (Blade/Lower) ....	2
Plastic Washers 10mm (Blade/Lower) .....	2
Flat Washers 10mm (Blade/Lower).....	2
Lock Washers 10mm (Blade/Lower) .....	2
Hex Nuts M10-1.5 (Blade/Lower).....	2
Hex Bolts M8-1.25 x 20 (Drum Pieces).....	10
Flat Washers 8mm (Drum Pieces) .....	10
Lock Washers 8mm (Drum Pieces) .....	10
Phillips Screws M10-1.5 x 20 (Blade/Upper) ....	2
Flat Washers 10mm (Blade/Upper).....	2
Lock Washers 10mm (Blade/Upper) .....	2
Hex Nuts M10-1.5 (Blade/Upper) .....	2
Hex Bolt M8-1.25 x 65 (Motor Assembly) .....	1
Flat Washers 8mm (Motor Assembly).....	3
Lock Washers 8mm (Motor Assembly) .....	3
Hex Nuts M8-1.25 (Motor Assembly).....	3
Hex Bolts M8-1.25 x 20 (Tipping Wheel) .....	2
Flat Washers 8mm (Tipping Wheel).....	2
Lock Washers 8mm (Tipping Wheel) .....	2
Hex Nuts M8-1.25 (Tipping Wheel).....	2

## NOTICE

If you cannot find an item on this list, carefully check around/inside the machine and packaging materials. Often, these items get lost in packaging materials while unpacking or they are pre-installed at the factory.



# Assembly

## To assemble the cement mixer:

1. Insert the wheels on the axles and secure them in place with the hairpin cotter pins, as shown in **Figure 4**.

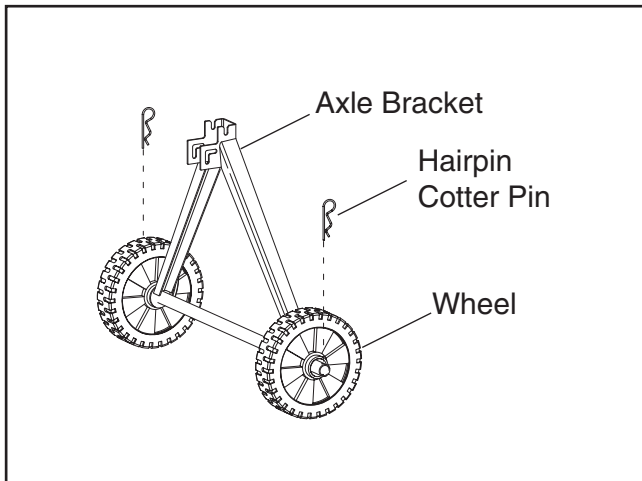

**Figure 4.** Wheels installed on axles.

2. Attach the support leg to the frame with two M8-1.25 x 65 hex bolts on one side and two 8mm flat washers, lock washers, and hex nuts on the other side (see **Figure 5**).

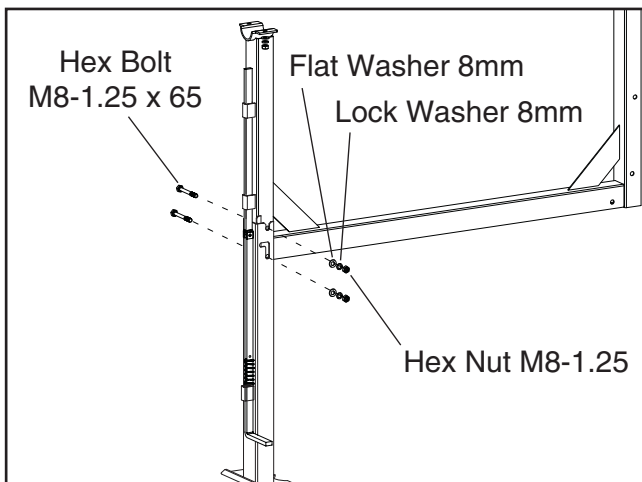

**Figure 5.** Support leg installation.

3. Connect the upper and lower plunger rods together with an M6-1 x 25 hex bolt and M6-1 lock nut, then insert the cotter pin where shown in **Figure 6**. Bend each leg of the cotter pin outward so it can't fall out.

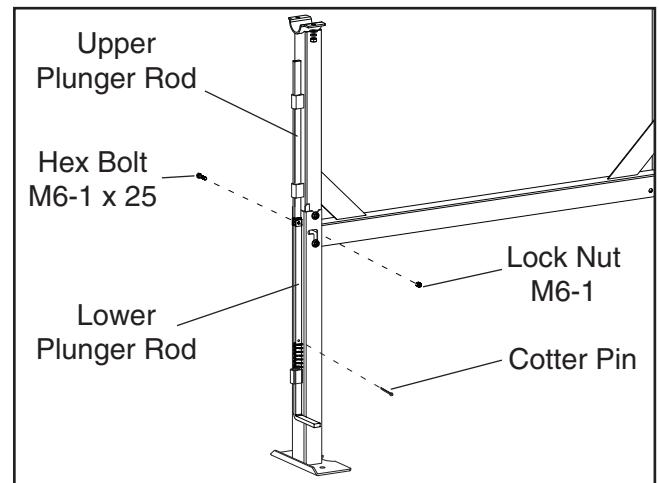

**Figure 6.** Plunger rod installation.

4. Attach the axle bracket to the frame with two M8-1.25 x 65 hex bolts on one side and two 8mm flat washers, lock washers, and hex nuts on the other side (see **Figure 7**).

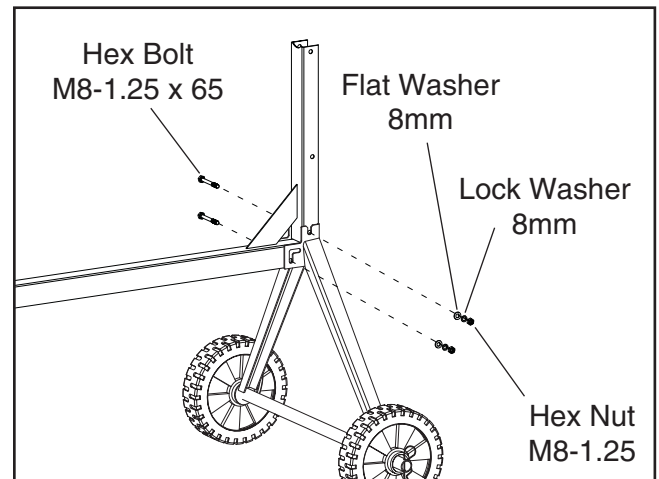

**Figure 7.** Attaching axle bracket to frame.



- With the help of another person, place the lower drum on the frame assembly, as shown in **Figure 8**. The gear guard **MUST** remain installed on the lower drum. If, for any reason, it is not installed in the location shown in **Figure 8**, then install it now.



**Figure 8.** Lower drum on frame.

- Attach the bearing block to the frame with one M8-1.25 x 60 hex bolt on one side and one 8mm flat washer, lock washer, and hex nut on the other side (see **Figure 9**).



**Figure 9.** Bearing block installed over shaft and attached to frame.

- Place the upper bracket over the pivot shaft, and attach the upper bracket to the frame with two M8-1.25 x 20 hex bolts on one side and two 8mm flat washers, lock washers, and hex nuts on the other side (see **Figure 10**).

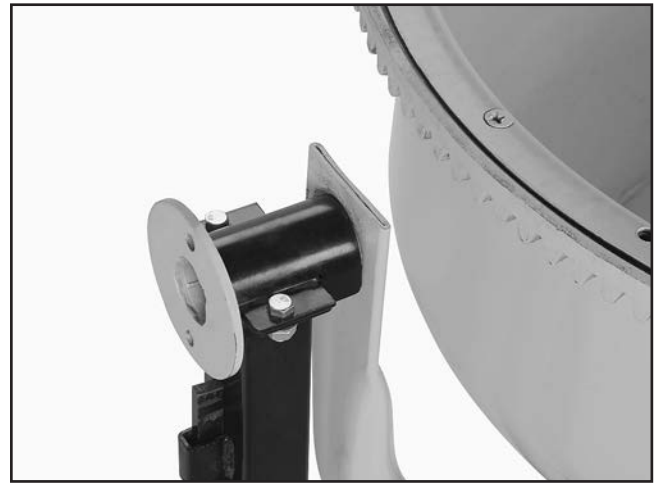

**Figure 10.** Upper bracket installed.

- Attach the lower end of the mixing blades to the lower drum, placing a plastic washer between the mixing blade and the drum mounting holes (see **Figure 11**). At each attachment, use an M10-1.5 x 20 Phillips head screw on one side and a 10mm flat washer, lock washer, and hex nut on the other side. *Leave the fasteners loose for now.*

**Note:** *Since these fasteners will be regularly exposed to water, we suggest coating them with anti-seize or bearing grease before assembly to prevent them from rusting together. Repeat this process on the fasteners used in **Steps 9–10**, as well.*



**Figure 11.** Lower end of mixing blades attached to lower drum.



9. Place the upper drum on the lower drum with the gasket between them. Align the arrows shown in **Figure 12**, and secure the upper and lower drum pieces together with ten M8-1.25 x 20 hex bolts, 8mm lock washers, and 8mm flat washers.

**Note:** *Tighten these hex bolts progressively in a criss-cross pattern for even tension all the way around the drum.*



**Figure 12.** Upper drum attached to lower drum.

10. Place a plastic washer between the mounting holes on the upper end of the mixing blades and the upper drum. Insert an M10-1.5 x 20 Phillips screw from the outside of the drum through each mixing blade. Secure each screw with a 10mm flat washer, lock washer, and hex nut from the inside (see **Figure 13**). *Completely tighten all the mixing blade fasteners now.*



**Figure 13.** Upper part of mixing blades attached to upper drum.

11. Slide the motor assembly onto the bearing block shaft, then secure the motor assembly to the frame (see **Figure 14**). Use two 8mm flat washers, lock washers, and hex nuts on the motor assembly studs. Slide the remaining M8-1.25 x 65 hex bolt through the motor assembly and frame, then secure on the other side with an 8mm flat washer, lock washer, and hex nut.



**Figure 14.** Motor assembly attached to frame.

12. Attach the tipping wheel to the lower drum pivot bar (see **Figure 15**). Use two M8-1.25 x 20 hex bolts on one side and two 8mm flat washers, 8mm lock washers, and M8-1.25 hex nuts on the other side.

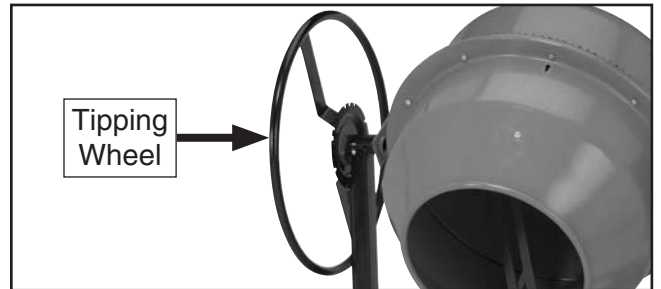

**Figure 15.** Tipping wheel attached.



# Test Run

---

Once assembly is complete, test run the machine to ensure it is properly connected to power and safety components are functioning properly.

If you find an unusual problem during the test run, immediately stop the machine, disconnect it from power, and fix the problem **BEFORE** operating the machine again. The **Troubleshooting** table in the **SERVICE** section of this manual can help.

## **WARNING**

**Serious injury or death can result from using this machine BEFORE understanding its controls and related safety information. DO NOT operate, or allow others to operate, machine until the information is understood.**

## **WARNING**

**DO NOT start machine until all preceding setup instructions have been performed. Operating an improperly set up machine may result in malfunction or unexpected results that can lead to serious injury, death, or machine/property damage.**

### **To test run machine:**

1. Clear all setup tools away from machine.
2. Connect machine to power supply.
3. Turn machine **ON**, verify motor operation, and then turn machine **OFF**. The motor should run smoothly and without unusual problems or noises.



# SECTION 4: OPERATIONS

## Operation Safety

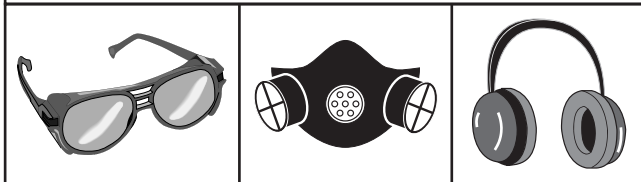
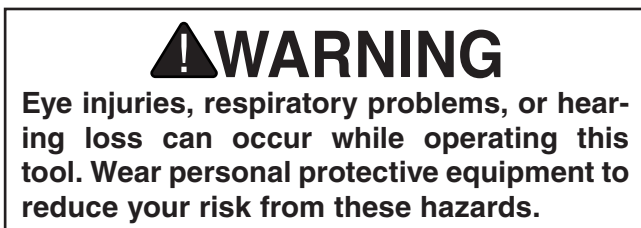

**NOTICE**

If you are not experienced with this type of machine, **WE STRONGLY RECOMMEND** that you seek additional training outside of this manual. Read books/magazines or get formal training before beginning any projects. Regardless of the content in this section, Grizzly Industrial will not be held liable for accidents caused by lack of training.

## Operation Tips

Follow the tips below when using the cement mixer:

- Before using your cement mixer, coat the inside of the mixing drum with a light layer of oil. Refer to **Lubrication on page 17** for more details.
- Spray the inside surface of the cement mixer with a small amount of water before adding cement (in addition to the lubrication steps above). This will make it easier to clean after operation. *Avoid spraying water on the switch or motor cover!*
- The mixer works more effectively and quickly when batches are half the maximum recommended mixture load, or if mixture materials are added slowly (while mixing), rather than all at one time.
- The maximum recommended mixture load is 3.2 cubic feet. This equates to:
  - Six 60 lb. bags
  - Four 90 lb. bags

**!CAUTION**  
Do not put hands, shovels, or other tools into the mixing drum while it is turning, or injury or equipment damage may occur.

**!CAUTION**  
Children can hurt themselves if playing on this mixer. If this machine is not stored in a locked facility, always disconnect power when leaving it unattended.



# SECTION 5: ACCESSORIES

## Basic Eye Protection

T20502—Face Shield Crown Protector 7"

T20503—Face Shield Window

T20451—"Kirova" Clear Safety Glasses

T20452—"Kirova" Anti-Reflective S. Glasses

H7194—Bifocal Safety Glasses 1.5

H7195—Bifocal Safety Glasses 2.0

H7196—Bifocal Safety Glasses 2.5

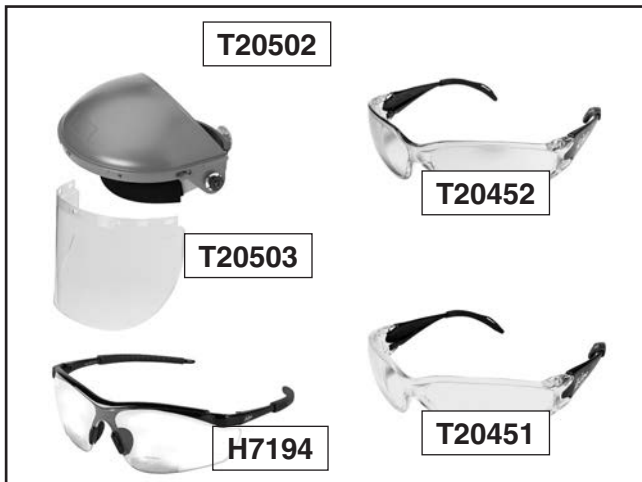

Figure 16. Assortment of basic eye protection.

## H0936—Concrete Hand Tools

Take on those expensive concrete jobs yourself with this 4-piece concrete hand tool set and get results just like the pros. Includes a 11" x 4-1/2" finishing trowel, 14" x 4" finishing trowel, 6" edging trowel and 6" jointing trowel.

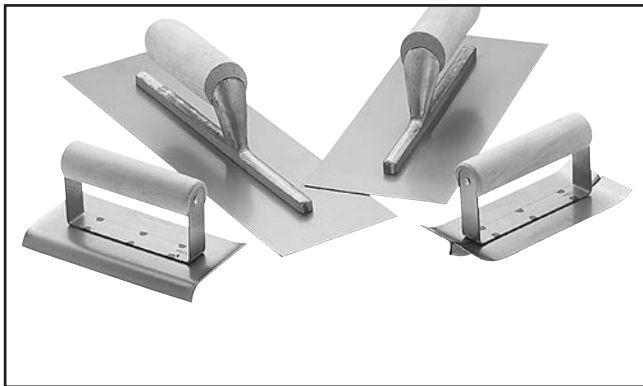

Figure 17. H0936 Concrete Hand Tools.

## T21607—PVC Gloves

These PVC gloves resist oil, chemicals, and abrasion. Great for oily machining applications and cleaning.



Figure 18. PVC Gloves

## H0605—All-Steel Round-Head Shovel

The D-handle on this shovel makes trenching or turning the garden soil an easy task. The top edge of the shovel has a rolled edge of the shovel has a rolled edge to make it easier to apply foot pressure for digging in hard earth. The 14 gauge steel shovel head is swaged and welded onto a 1-3/8" diameter steel handle which is ribbed for strength. Shovel area measures approximately 9" wide by 11-1/2" deep, overall length is 38".

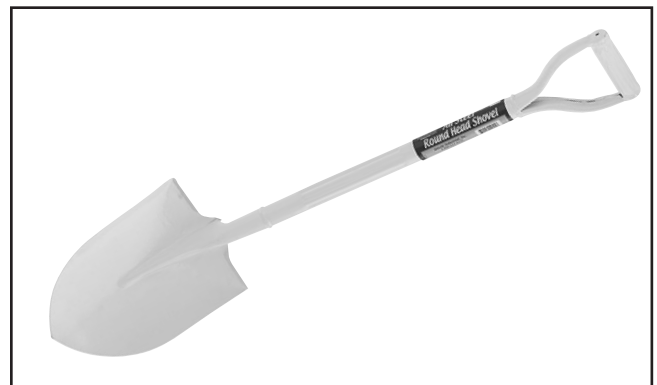
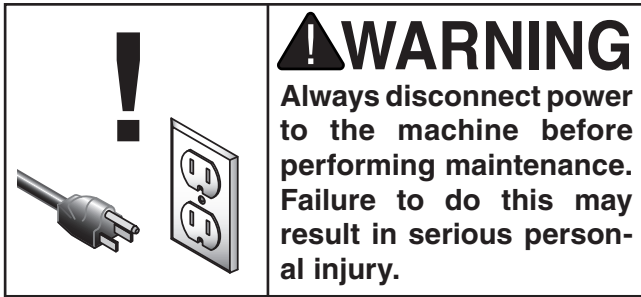

Figure 19. All-Steel Round-Head Shovel.



# SECTION 5: MAINTENANCE



## Lubrication

Remove the gear cover/guard. Lubricate the driving gear with a high-quality multi-purpose grease. Re-install the gear cover/guard before reconnecting your machine to power (see **Figure 20**).

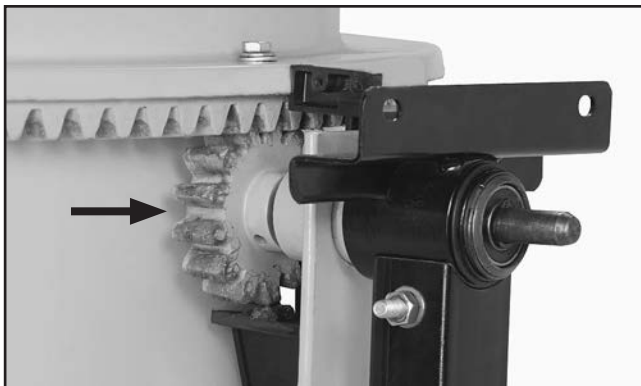

**Figure 20.** Drive gear location.

Before every use, and while the mixing drum and blades are clean and dry, wipe down the inside of the mixing drum and blades with a light coat of motor, hydraulic, or vegetable oil. This will prevent most cement from sticking to these surfaces and will make cleaning very easy.

An alternative to coating the drum interior with oil is to spray the oil. Since most oils are too thick to spray, use a mixture of half oil and half diesel fuel. This is a common spray mixture used in commercial concrete construction to prevent sticking.

## Cleaning

- Always unplug the cement mixer before cleaning.
- Avoid getting water on the motor or switch while cleaning. If you do, allow the components to thoroughly dry before plugging in the motor.
- The easiest way to clean the drum is by hosing it out with water. (Cleaning is made much easier if you follow the **Lubrication** procedures in this section before using your cement mixer.)
- Always clean the mixing drum immediately after using it. As a general rule, the sooner you clean, the easier it will be.
- For tough to remove buildup, use a stiff bristle brush or a rag to make cleaning easier.
- Small, hardened cement splatters usually can be removed by rubbing with a dry rag.
- Hardened cement can be scraped, chiseled or pounded off with a hammer; however, these actions **WILL** damage the surface area of the drum, making it harder to clean in the future.

## Drive Belt

Avoid getting grease or oil on the drive belt or pulleys. Check the drive belt, as part of a monthly inspection for proper tension and belt condition. Cracking and glazing could result in belt failure. Replace the belt if such conditions appear.



# SECTION 6: WIRING

These pages are current at the time of printing. However, in the spirit of improvement, we may make changes to the electrical systems of future machines. Compare the manufacture date of your machine to the one stated in this manual, and study this section carefully.

If there are differences between your machine and what is shown in this section, call Technical Support at (570) 546-9663 for assistance BEFORE making any changes to the wiring on your machine. An updated wiring diagram may be available. **Note:** *Please gather the serial number and manufacture date of your machine before calling. This information can be found on the main machine label.*

## WARNING

### Wiring Safety Instructions

**SHOCK HAZARD.** Working on wiring that is connected to a power source is extremely dangerous. Touching electrified parts will result in personal injury including but not limited to severe burns, electrocution, or death. Disconnect the power from the machine before servicing electrical components!

**MODIFICATIONS.** Modifying the wiring beyond what is shown in the diagram may lead to unpredictable results, including serious injury or fire. This includes the installation of unapproved after-market parts.

**WIRE CONNECTIONS.** All connections must be tight to prevent wires from loosening during machine operation. Double-check all wires disconnected or connected during any wiring task to ensure tight connections.

**CIRCUIT REQUIREMENTS.** You MUST follow the requirements at the beginning of this manual when connecting your machine to a power source.

**WIRE/COMPONENT DAMAGE.** Damaged wires or components increase the risk of serious personal injury, fire, or machine damage. If you notice that any wires or components are damaged while performing a wiring task, replace those wires or components.

**MOTOR WIRING.** The motor wiring shown in these diagrams is current at the time of printing but may not match your machine. If you find this to be the case, use the wiring diagram inside the motor junction box.















**CAPACITORS/INVERTERS.** Some capacitors and power inverters store an electrical charge for up to 10 minutes after being disconnected from the power source. To reduce the risk of being shocked, wait at least this long before working on capacitors.

**EXPERIENCING DIFFICULTIES.** If you are experiencing difficulties understanding the information included in this section, contact our Technical Support at (570) 546-9663.

#### NOTICE

The photos and diagrams included in this section are best viewed in color. You can view these pages in color at [www.grizzly.com](http://www.grizzly.com).

#### COLOR KEY

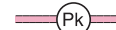
BLACK 	BLUE 	YELLOW 	LIGHT BLUE 
WHITE 	BROWN 	YELLOW GREEN 	BLUE WHITE 
GREEN 	GRAY 	PURPLE 	TURQUOISE 
RED 	ORANGE 	PINK 	



# Wiring Diagram

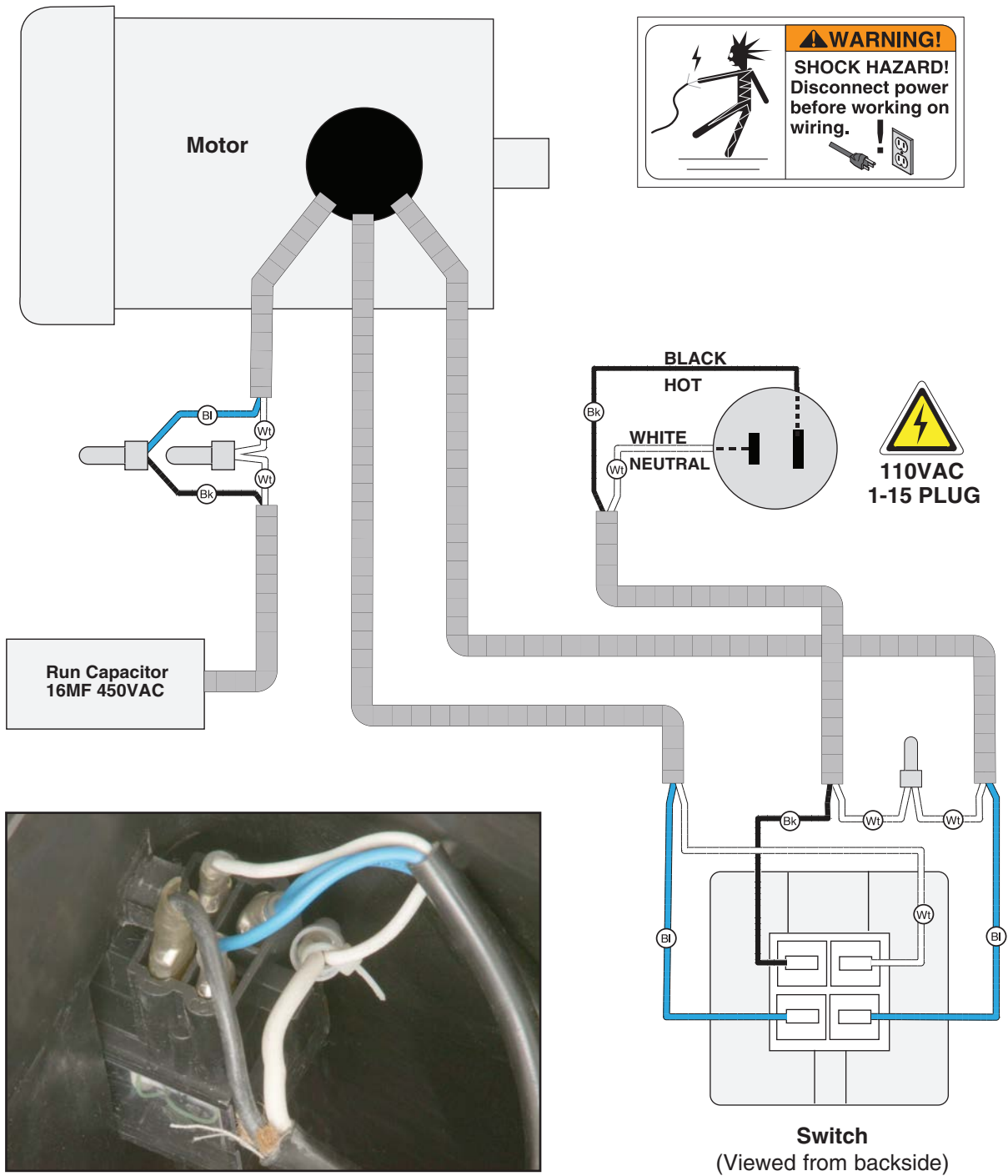
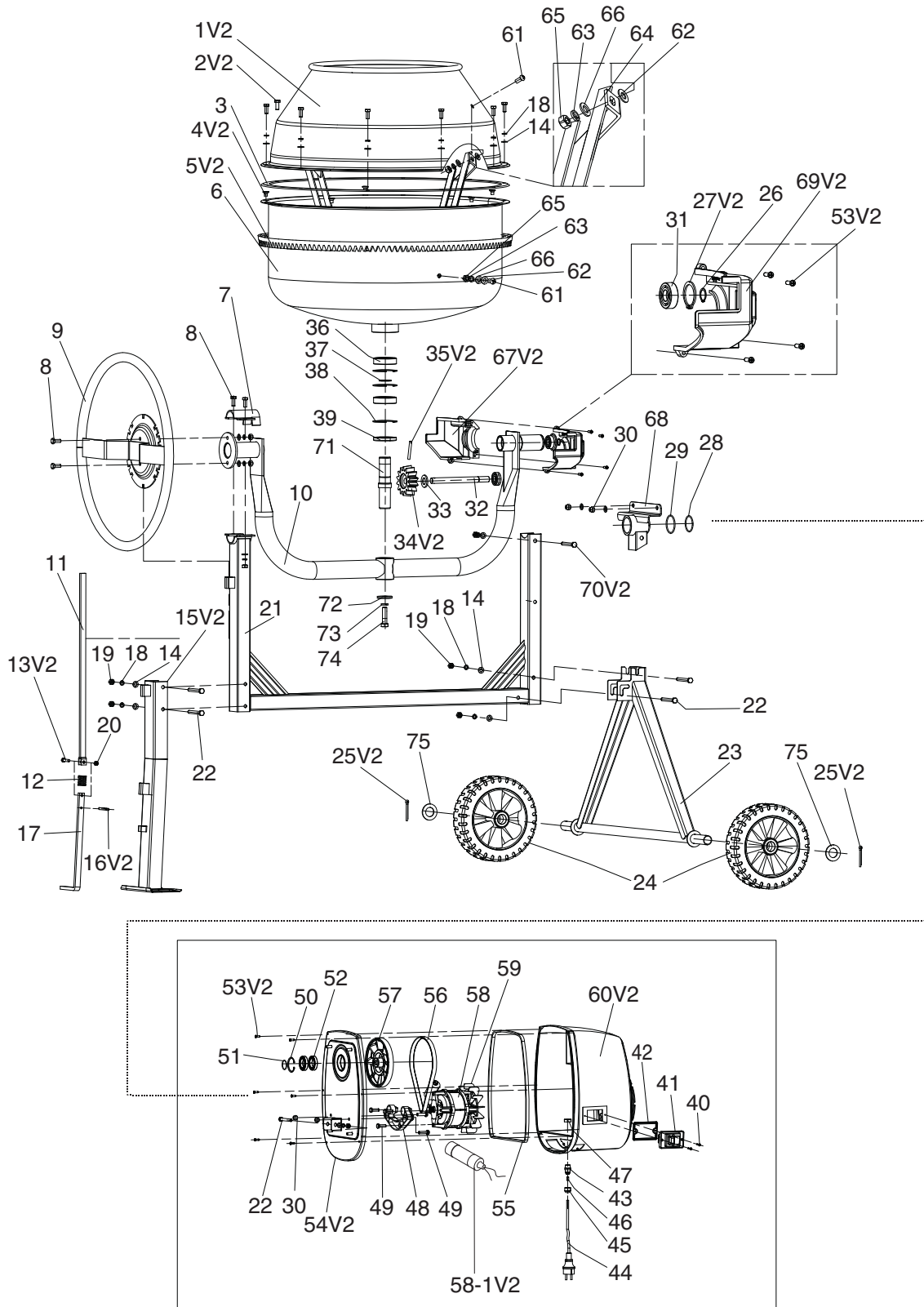

Figure 21. Switch wiring.



# SECTION 7: PARTS

## Main Breakdown



# Main Parts List

REF	PART #	DESCRIPTION
1V2	PH8172001V2	UPPER DRUM V2.05.12
2V2	PH8172002V2	HEX BOLT M8-1.25 X 20
3	PH8172003	RUBBER GASKET
4V2	PH8172004V2	FLAT HD SCR M8-1.25 X 12
5V2	PH8172005V2	BIG COGWHEEL V2.05.12
6	PH8172006	LOWER DRUM
7	PH8172007	UPPER BRACKET
8	PH8172008	HEX BOLT M8-1.25 X 20
9	PH8172009	TIPPING WHEEL
10	PH8172010	SUPPORT ARM
11	PH8172011	UPPER PLUNGER ROD
12	PH8172012	COMPRESSION SPRING
13V2	PH8172013V2	HEX BOLT M6-1 X 30
14	PH8172014	FLAT WASHER 8MM
15V2	PH8172015V2	SUPPORT LEG V2.05.12
16V2	PH8172016V2	COTTER PIN 4 X 25 V2.05.12
17	PH8172017	LOWER PLUNGER ROD
18	PH8172018	LOCK WASHER 8MM
19	PH8172019	HEX NUT M8-1.25
20	PH8172020	LOCK NUT M6-1
21	PH8172021	FRAME
22	PH8172022	HEX BOLT M8-1.25 X 70
23	PH8172023	AXLE BRACKET
24	PH8172024	WHEEL
25V2	PH8172025V2	COTTER PIN 5 X 40MM STANDARD
26	PH8172026	EXT RETAINING RING 15MM
27V2	PH8172027V2	EXT RETAINING RING 47MM
28	PH8172028	SNAP RING 42MM
29	PH8172029	O-RING 42 X 2.65
30	PH8172030	LOCK NUT M8-1.25
31	PH8172031	BALL BEARING 6202ZZ
32	PH8172032	DRIVE SHAFT
33	PH8172033	SLEEVE
34V2	PH8172034V2	DRIVE PINION V2.05.12
35V2	PH8172035V2	LOCK PIN 5 X 40 V2.05.12
36	PH8172036	BALL BEARING 6206ZZ
37	PH8172037	EXT RETAINING RING 30MM
38	PH8172038	INT RETAINING RING 62MM

REF	PART #	DESCRIPTION
39	PH8172039	DUSTPROOF COVER
40	PH8172040	TAP SCREW M3.5 X 16
41	PH8172041	SWITCH
42	PH8172042	GASKET
43	PH8172043	STRAIN RELIEF
44	PH8172044	POWER CORD 18G 2W 12" 1-15 P
45	PH8172045	STRAIN RELIEF NUT
46	PH8172046	STRAIN RELIEF RUBBER
47	PH8172047	STRAIN RELIEF NUT
48	PH8172048	MOTOR MOUNT BRACKET
49	PH8172049	HEX BOLT M8-1.25 X 30
50	PH8172050	INT RETAINING RING 47MM
51	PH8172051	SNAP RING 30MM
52	PH8172052	BALL BEARING 6906ZZ
53V2	PH8172053V2	TAP SCREW M4 X 16
54V2	PH8172054V2	END PLATE V2.05.12
55	PH8172055	GASKET
56	PH8172056	V-BELT 6PJ630
57	PH8172057	IDLER PULLEY
58	PH8172058	MOTOR 1HP 110V 1-PH
58-1V2	PH8172058-1V2	R CAPACITOR 16M 450V 1-3/8 x 3 V2.10.14
59	PH8172059	MOTOR FAN
60V2	PH8172060V2	MOTOR COVER V2.05.12
61	PH8172061	PHLP HD SCR M10-1.5 X 20
62	PH8172062	PVC WASHER 10MM
63	PH8172063	LOCK WASHER 10MM
64	PH8172064	MIXING BLADE
65	PH8172065	HEX NUT M10-1.5
66	PH8172066	FLAT WASHER 10MM
67V2	PH8172067V2	SHORT GEAR GUARD V2.05.12
68	PH8172068	BEARING BLOCK
69V2	PH8172069V2	GEAR GUARD V2.05.12
70V2	PH8172070V2	HEX BOLT M8-1.25 X 65
71	PH8172071	FIXED SHAFT
72	PH8172072	FLAT WASHER 12MM
73	PH8172073	LOCK WASHER 12MM
74	PH8172074	HEX BOLT M12-1.75 X 35
75	PH8172075	FLAT WASHER 27MM



# Labels & Cosmetics

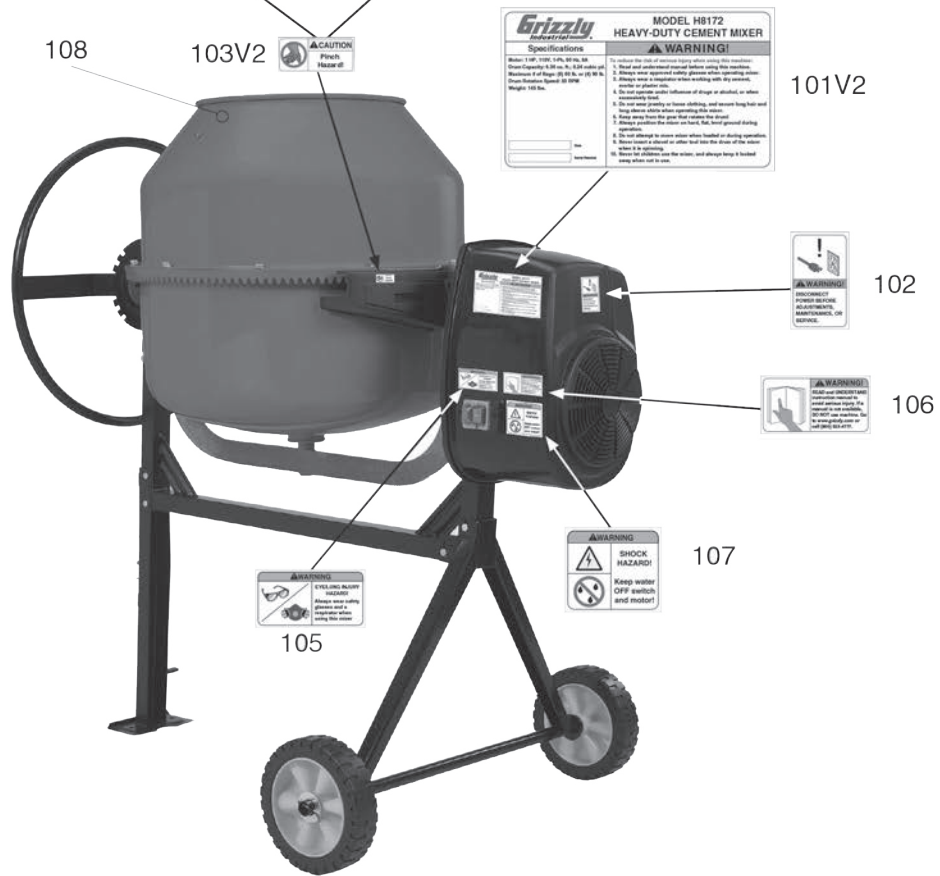
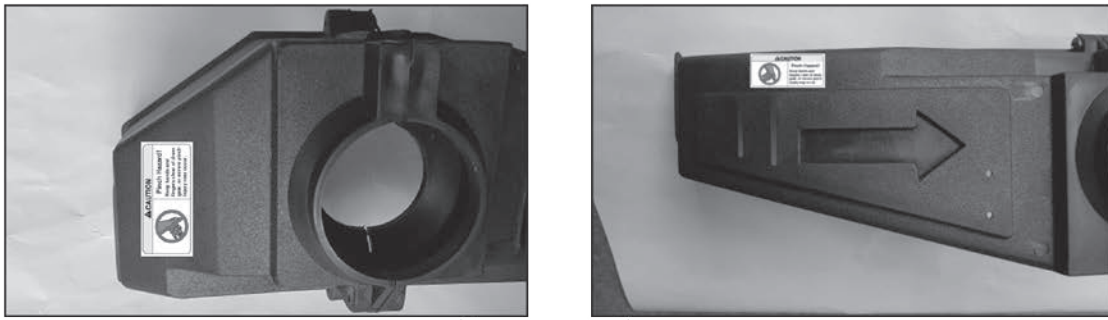

REF	PART #	DESCRIPTION
101V2	PH8172101V2	MACHINE ID LABEL V2.05.12
102	PH8172102	SMALL DISCONNECT PWR LABEL
103V2	PH8172103V2	SMALL DRUM PINCH LABEL V2.05.12
105	PH8172105	SMALL EYE/LUNG LABEL

REF	PART #	DESCRIPTION
106	PH8172106	SMALL READ MANUAL LABEL
107	PH8172107	MOTOR/WATER SHOCK LABEL
108	PH8172108	GRIZZLY GREEN TOUCH-UP PAINT

## WARNING

Safety labels warn about machine hazards and ways to prevent injury. The owner of this machine **MUST** maintain the original location and readability of the labels on the machine. If any label is removed or becomes unreadable, **REPLACE** that label before using the machine again. Contact Grizzly at (800) 523-4777 or [www.grizzly.com](http://www.grizzly.com) to order new labels.





# WARRANTY CARD

Name \_\_\_\_\_

Street \_\_\_\_\_

City \_\_\_\_\_ State \_\_\_\_\_ Zip \_\_\_\_\_

Phone # \_\_\_\_\_ Email \_\_\_\_\_

Model # \_\_\_\_\_ Order # \_\_\_\_\_ Serial # \_\_\_\_\_

*The following information is given on a voluntary basis. It will be used for marketing purposes to help us develop better products and services. **Of course, all information is strictly confidential.***

**1. How did you learn about us?**

- |  |                                  |                                  |
|--|----------------------------------|----------------------------------|
| <input type="checkbox"/> Advertisement | <input type="checkbox"/> Friend  | <input type="checkbox"/> Catalog |
| <input type="checkbox"/> Card Deck     | <input type="checkbox"/> Website | <input type="checkbox"/> Other:  |

**2. Which of the following magazines do you subscribe to?**

- |   |  |   |
|---|--|---|
| <input type="checkbox"/> Cabinetmaker & FDM     | <input type="checkbox"/> Popular Science     | <input type="checkbox"/> Wooden Boat          |
| <input type="checkbox"/> Family Handyman        | <input type="checkbox"/> Popular Woodworking | <input type="checkbox"/> Woodshop News        |
| <input type="checkbox"/> Hand Loader            | <input type="checkbox"/> Precision Shooter   | <input type="checkbox"/> Woodsmith            |
| <input type="checkbox"/> Handy                  | <input type="checkbox"/> Projects in Metal   | <input type="checkbox"/> Woodwork             |
| <input type="checkbox"/> Home Shop Machinist    | <input type="checkbox"/> RC Modeler          | <input type="checkbox"/> Woodworker West      |
| <input type="checkbox"/> Journal of Light Cont. | <input type="checkbox"/> Rifle               | <input type="checkbox"/> Woodworker's Journal |
| <input type="checkbox"/> Live Steam             | <input type="checkbox"/> Shop Notes          | <input type="checkbox"/> Other:               |
| <input type="checkbox"/> Model Airplane News    | <input type="checkbox"/> Shotgun News        |   |
| <input type="checkbox"/> Old House Journal      | <input type="checkbox"/> Today's Homeowner   |   |
| <input type="checkbox"/> Popular Mechanics      | <input type="checkbox"/> Wood                |   |

**3. What is your annual household income?**

- |  |  |  |
|--|--|--|
| <input type="checkbox"/> \$20,000-\$29,000 | <input type="checkbox"/> \$30,000-\$39,000 | <input type="checkbox"/> \$40,000-\$49,000 |
| <input type="checkbox"/> \$50,000-\$59,000 | <input type="checkbox"/> \$60,000-\$69,000 | <input type="checkbox"/> \$70,000+         |

**4. What is your age group?**

- |                                |                                |                                |
|--------------------------------|--------------------------------|--------------------------------|
| <input type="checkbox"/> 20-29 | <input type="checkbox"/> 30-39 | <input type="checkbox"/> 40-49 |
| <input type="checkbox"/> 50-59 | <input type="checkbox"/> 60-69 | <input type="checkbox"/> 70+   |

**5. How long have you been a woodworker/metalworker?**

- |                                    |                                    |                                     |                                    |
|------------------------------------|------------------------------------|-------------------------------------|------------------------------------|
| <input type="checkbox"/> 0-2 Years | <input type="checkbox"/> 2-8 Years | <input type="checkbox"/> 8-20 Years | <input type="checkbox"/> 20+ Years |
|------------------------------------|------------------------------------|-------------------------------------|------------------------------------|

**6. How many of your machines or tools are Grizzly?**

- |                              |                              |                              |                              |
|------------------------------|------------------------------|------------------------------|------------------------------|
| <input type="checkbox"/> 0-2 | <input type="checkbox"/> 3-5 | <input type="checkbox"/> 6-9 | <input type="checkbox"/> 10+ |
|------------------------------|------------------------------|------------------------------|------------------------------|

**7. Do you think your machine represents a good value?**  Yes  No

**8. Would you recommend Grizzly Industrial to a friend?**  Yes  No

**9. Would you allow us to use your name as a reference for Grizzly customers in your area?**  
**Note: We never use names more than 3 times.**  Yes  No

**10. Comments:** \_\_\_\_\_

\_\_\_\_\_  
\_\_\_\_\_

CUT ALONG DOTTED LINE

FOLD ALONG DOTTED LINE

\_\_\_\_\_  
\_\_\_\_\_  
\_\_\_\_\_



Place  
Stamp  
Here



**GRIZZLY INDUSTRIAL, INC.**  
P.O. BOX 2069  
BELLINGHAM, WA 98227-2069



FOLD ALONG DOTTED LINE

Send a Grizzly Catalog to a friend:

Name \_\_\_\_\_  
Street \_\_\_\_\_  
City \_\_\_\_\_ State \_\_\_\_\_ Zip \_\_\_\_\_

TAPE ALONG EDGES--PLEASE DO NOT STAPLE

# WARRANTY & RETURNS

---

---

Grizzly Industrial, Inc. warrants every product it sells for a period of **1 year** to the original purchaser from the date of purchase. This warranty does not apply to defects due directly or indirectly to misuse, abuse, negligence, accidents, repairs or alterations or lack of maintenance. This is Grizzly's sole written warranty and any and all warranties that may be implied by law, including any merchantability or fitness, for any particular purpose, are hereby limited to the duration of this written warranty. We do not warrant or represent that the merchandise complies with the provisions of any law or acts unless the manufacturer so warrants. In no event shall Grizzly's liability under this warranty exceed the purchase price paid for the product and any legal actions brought against Grizzly shall be tried in the State of Washington, County of Whatcom.

We shall in no event be liable for death, injuries to persons or property or for incidental, contingent, special, or consequential damages arising from the use of our products.

To take advantage of this warranty, contact us by mail or phone and give us all the details. We will then issue you a "Return Number," which must be clearly posted on the outside as well as the inside of the carton. We will not accept any item back without this number. Proof of purchase must accompany the merchandise.

The manufacturers reserve the right to change specifications at any time because they constantly strive to achieve better quality equipment. We make every effort to ensure that our products meet high quality and durability standards and we hope you never need to use this warranty.

Please feel free to write or call us if you have any questions about the machine or the manual.

Thank you again for your business and continued support. We hope to serve you again soon.

***grizzly.com***®  
**TOOL WEBSITE**

Buy Direct and Save with Grizzly® – Trusted, Proven and a Great Value!  
~Since 1983~

*Visit Our Website Today For  
Current Specials!*

**ORDER  
24 HOURS A DAY!  
1-800-523-4777**

