



MODEL H6194 3/8" INDUSTRIAL AIR DRILL INSTRUCTION SHEET

! WARNING	
	EYE/EAR INJURY HAZARD! Wear safety glasses and hearing protection during use of this tool!
	INJURY HAZARD! Always disconnect tool from air to prevent unexpected operation during service!
	EXPLOSION HAZARD! Never exceed 90 PSI!



Figure 1. Model H6194.

Introduction

Heavy-duty industrial air drill features paddle switch for easy control, a 3/8" Jacobs® chuck, rear air exhaust and rugged aluminum body. It has a 22,000 RPM free speed with 4 CFM average air consumption.

- A. Industrial Air Drill 1
- B. 3/8" Jacobs® Chuck 1
- C. Chuck Key 1
- D. Wrench 1

Operation

Screw the chuck on the arbor and tighten with the wrench provided. Add a 1/4" MNPT air fitting and connect to your regulated compressed air supply. Do not exceed 90 PSI!

This industrial air drill **MUST** have 3-4 drops of oil directly dropped into the air fitting before each use as shown in **Figure 2**.

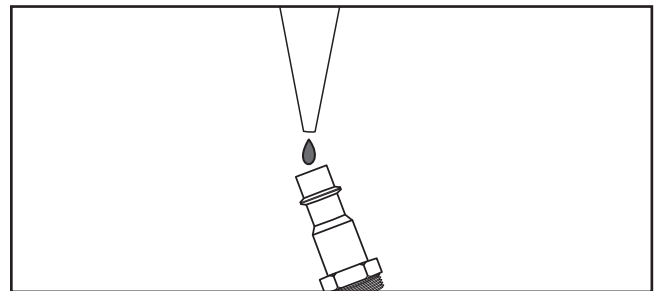

Figure 2. Lubricating directly into air fitting.

If you need help with your new pneumatic tool, call our Tech Support at: (570) 546-9663.

COPYRIGHT © APRIL, 2006 BY GRIZZLY INDUSTRIAL, INC.

WARNING: NO PORTION OF THIS MANUAL MAY BE REPRODUCED IN ANY SHAPE OR FORM WITHOUT THE WRITTEN APPROVAL OF GRIZZLY INDUSTRIAL, INC.

#PC8030 PRINTED IN CHINA

H6194 Parts Breakdown and List

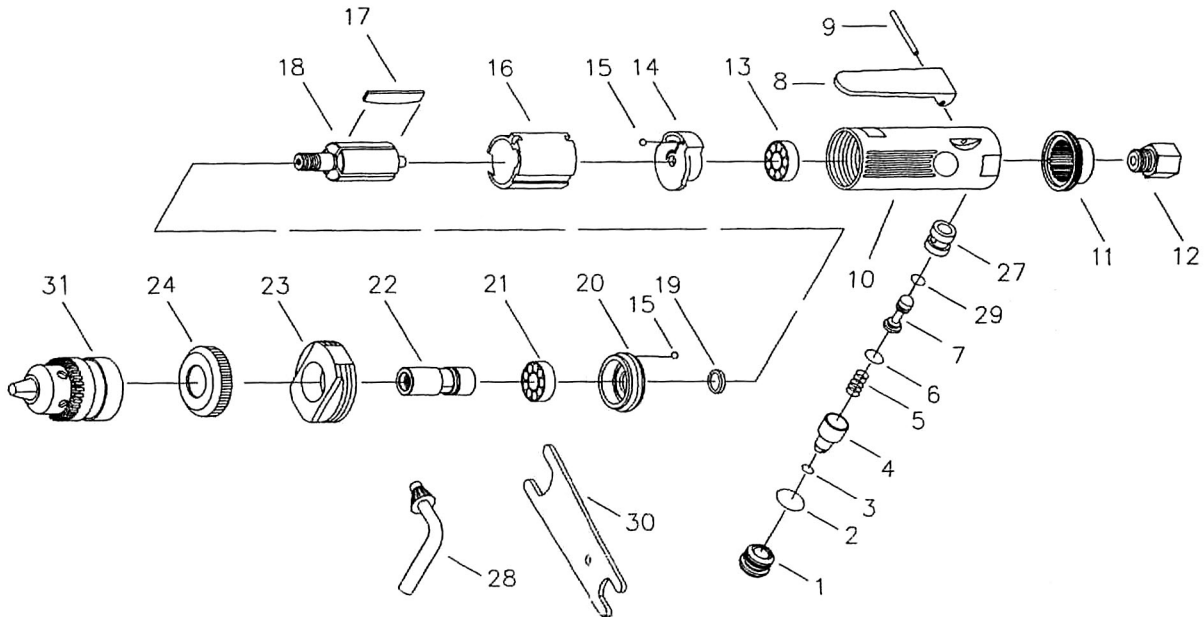

REF	PART #	DESCRIPTION
1	PH6194001	VALVE SCREW
2	PH6194002	O-RING
3	PH6194003	O-RING
4	PH6194004	AIR REGULATOR
5	PH6194005	SPRING
6	PH6194006	O-RING
7	PH6194007	VALVE STEM
8	PH6194008	LEVER PIN
9	PH6194009	THROTTLE PIN
10	PH6194010	MOTOR HOUSING
11	PH6194011	EXHAUST DEFLECTOR
12	PH6194012	AIR INLET
13	PH6194013	BALL BEARING
14	PH6194014	REAR END PLATE
15	PH6194015	STEEL BALL

REF	PART #	DESCRIPTION
16	PH6194016	CYLINDER
17	PH6194017	ROTOR BLADE
18	PH6194018	ROTOR
19	PH6194019	ROTOR COLLAR
20	PH6194020	FRONT END PLATE
21	PH6194021	BALL BEARING
22	PH6194022	SPINDLE
23	PH6194023	CLAMP NUT
24	PH6194024	HOUSING CAP
27	PH6194027	VALVE BUSHING
28	PH6194028	CHUCK KEY
29	PH6194029	O-RING
30	PH6194030	SPANNER WRENCH
31	PH6194031	CHUCK