

READ THIS FIRST



For questions or help with this product contact Tech Support at (570) 546-9663 or techsupport@grizzly.com

Model G0490/G0490X

*****IMPORTANT UPDATE*****

For Machines Mfd. Since 08/12
and Owner's Manual Revised 12/17

The following change was recently made since the owner's manual was printed:

- Steps added for adjusting cutterhead guard tension if necessary during replacement.

Aside from this information, all other content in the owner's manual applies and **MUST** be read and understood for your own safety. **IMPORTANT: Keep this update with the owner's manual for future reference.**

For questions or help, contact our Tech Support at (570) 546-9663 or techsupport@grizzly.com.

Adjusting Cutterhead Guard Tension

WARNING

The cutterhead guard is a critical safety feature. If it has been removed, you **MUST** install and verify its operation before using machine! Failure to properly install this guard will greatly increase the risk of serious personal injury. If the spring has lost factory-set tension, it **MUST** be reset for the guard to function properly.

Items Needed	Qty
Heavy Leather Gloves.....	1 Pair
Hex Wrenches 3, 6mm.....	1 Ea.
Straight Jaw Pliers 10"	1

To adjust cutterhead guard tension:

1. DISCONNECT MACHINE FROM POWER!
2. Loosen fence lock, move fence all the way back, then tighten fence lock.

3. Pull cutterhead guard back and let it go. It should spring back over cutterhead and rest against fence (see **Figure 1**).

— If cutterhead guard *does* spring back over cutterhead and rest against fence, cutterhead guard is properly tensioned. Proceed to **Step 7**.

— If cutterhead guard *does not* spring back over cutterhead and rest against fence, proceed to **Step 4**.

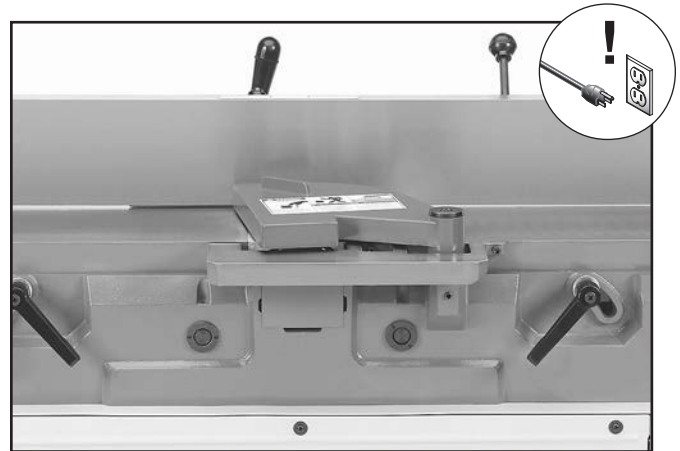

Figure 1. Cutterhead guard resting against fence.

COPYRIGHT © AUGUST, 2021 BY GRIZZLY INDUSTRIAL, INC.
WARNING: NO PORTION OF THIS MANUAL MAY BE REPRODUCED IN ANY SHAPE OR FORM WITHOUT THE WRITTEN APPROVAL OF GRIZZLY INDUSTRIAL, INC.
#KS22015 PRINTED IN CHINA

- Put on heavy leather gloves and loosen cap screw securing cutterhead guard clamp just enough so cutterhead guard moves freely (see **Figure 2**). DO NOT remove cap screw.

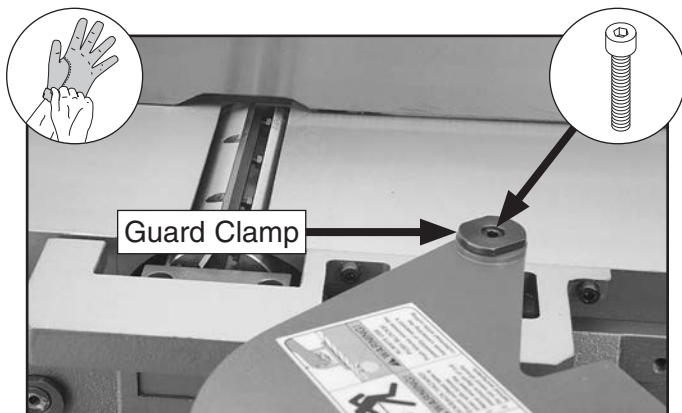

Figure 2. Location of cutterhead guard clamp and cap screw.

- With cutterhead guard resting against fence, use straight-jaw pliers to rotate cutterhead guard clamp a $\frac{1}{4}$ turn clockwise, then tighten cap screw to secure guard clamp, as shown in **Figure 3**.

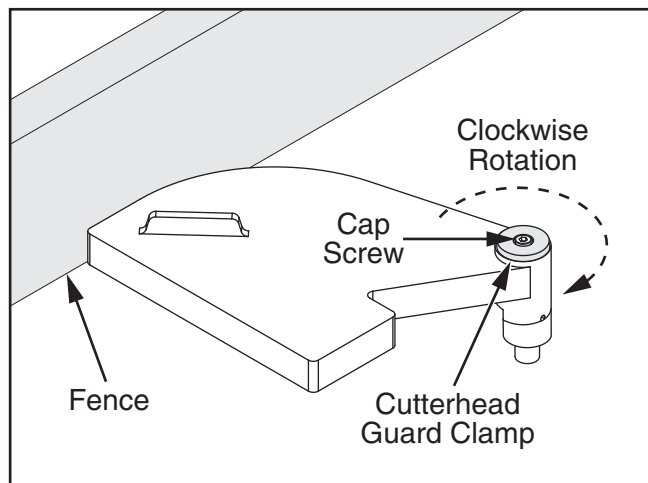

Figure 3. Rotating cutterhead guard clamp (tables removed for clarity).

- Pull cutterhead guard back and let it go. It should spring back over cutterhead and rest against fence.

- If cutterhead guard *does* spring back over cutterhead and rest against fence, cutterhead guard is properly tensioned. Proceed to **Step 7**.

- If cutterhead guard *does not* spring back over cutterhead and rest against fence, repeat **Steps 4–5** until properly adjusted, then proceed to **Step 7**.

- Verify cutterhead guard height is as low as possible (approximately $\frac{1}{8}$ " above infeed table) without dragging on infeed table/rabbeting extension.

- If cutterhead guard *is* as low as possible without dragging on infeed table/rabbeting extension, cutterhead guard height is correct. No further adjustment is required.

- If cutterhead guard *is not* as low as possible or drags on infeed table/rabbeting extension, loosen set screw securing cutterhead guard shaft, position cutterhead guard until it is approximately $\frac{1}{8}$ " above infeed table, then tighten set screw (see **Figure 4**).

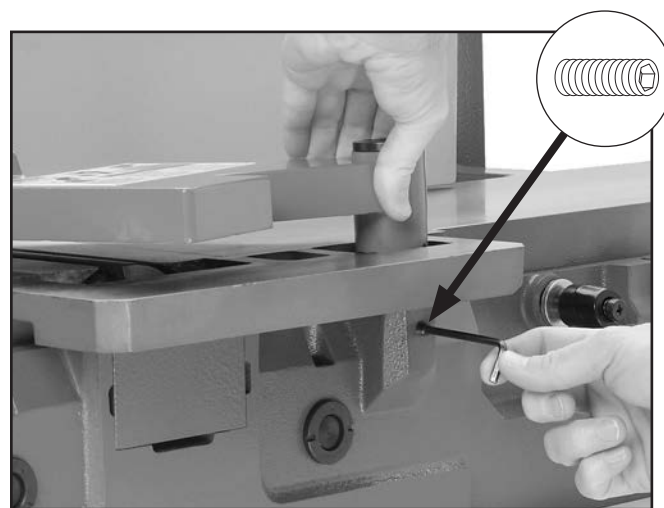
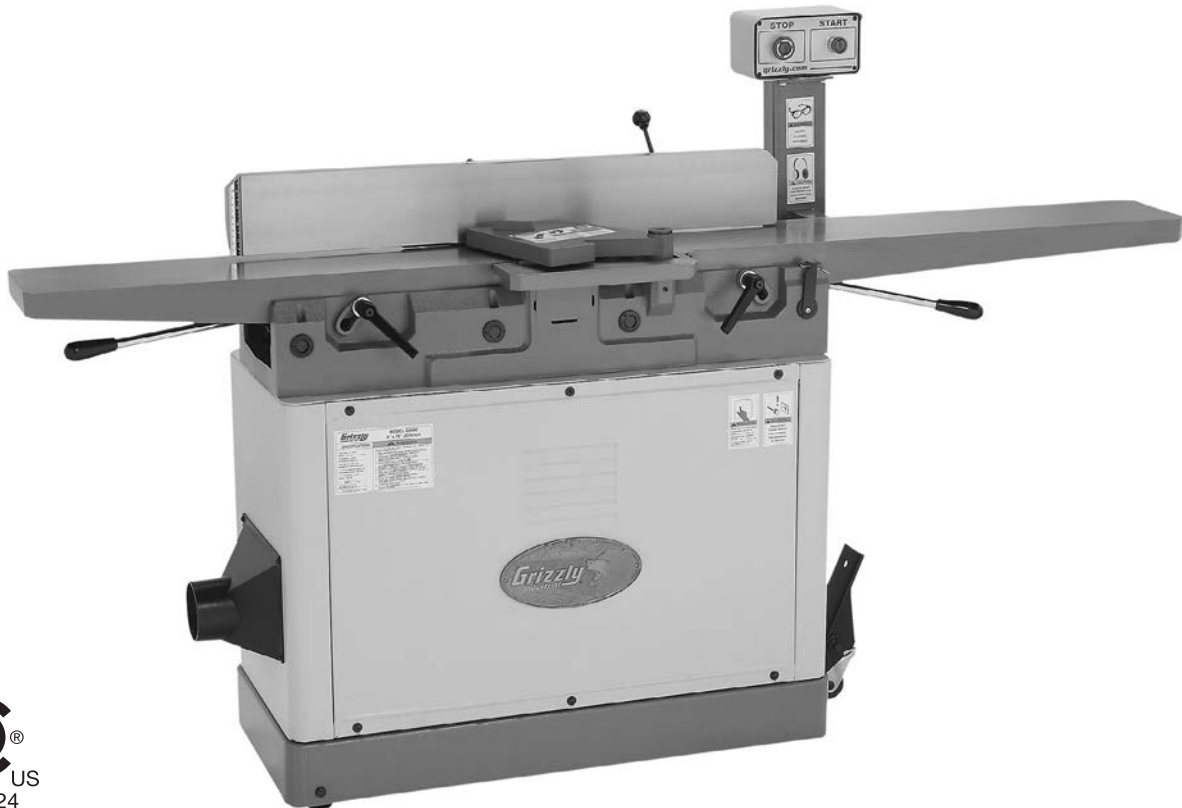

Figure 4. Location of cutterhead guard shaft set screw.



Grizzly **Industrial, Inc.**®

MODEL G0490/G0490X 8" X 76" JOINTER w/PARALLELOGRAM BEDS OWNER'S MANUAL *(For models manufactured since 8/12)*



C US
208624

COPYRIGHT © DECEMBER, 2005 BY GRIZZLY INDUSTRIAL, INC., REVISED DECEMBER, 2017 (HE)
**WARNING: NO PORTION OF THIS MANUAL MAY BE REPRODUCED IN ANY SHAPE
OR FORM WITHOUT THE WRITTEN APPROVAL OF GRIZZLY INDUSTRIAL, INC.**

#TR7845 PRINTED IN CHINA

V2.12.17



WARNING!

This manual provides critical safety instructions on the proper setup, operation, maintenance, and service of this machine/tool. Save this document, refer to it often, and use it to instruct other operators.

Failure to read, understand and follow the instructions in this manual may result in fire or serious personal injury—including amputation, electrocution, or death.

The owner of this machine/tool is solely responsible for its safe use. This responsibility includes but is not limited to proper installation in a safe environment, personnel training and usage authorization, proper inspection and maintenance, manual availability and comprehension, application of safety devices, cutting/sanding/grinding tool integrity, and the usage of personal protective equipment.

The manufacturer will not be held liable for injury or property damage from negligence, improper training, machine modifications or misuse.



WARNING!

Some dust created by power sanding, sawing, grinding, drilling, and other construction activities contains chemicals known to the State of California to cause cancer, birth defects or other reproductive harm. Some examples of these chemicals are:

- **Lead from lead-based paints.**
- **Crystalline silica from bricks, cement and other masonry products.**
- **Arsenic and chromium from chemically-treated lumber.**

Your risk from these exposures varies, depending on how often you do this type of work. To reduce your exposure to these chemicals: Work in a well ventilated area, and work with approved safety equipment, such as those dust masks that are specially designed to filter out microscopic particles.

Table of Contents

INTRODUCTION	2	SECTION 5: ACCESSORIES	32
Machine Description	2	SECTION 6: MAINTENANCE	33
Contact Info	2	Schedule	33
Manual Accuracy	2	Cleaning & Protecting	33
Identification	3	Lubrication	33
Controls & Components	4	SECTION 7: SERVICE	34
G0490 Machine Data Sheet	5	Troubleshooting	34
G0490X Machine Data Sheet	7	Servicing Poly V-Belt	36
SECTION 1: SAFETY	9	Aligning Pulleys	36
Safety Instructions for Machinery	9	Replacing/Tensioning V-Belt	36
Additional Safety for Jointers	11	Inspecting Knives (G0490)	37
SECTION 2: POWER SUPPLY	12	Inspecting Knife Height	37
Availability	12	Setting Knives (G0490)	37
Full-Load Current Rating	12	Cutterhead Inserts (G0490X)	38
Circuit Information	12	Checking/Adjusting Table Parallelism	39
Circuit Requirements	12	Checking Outfeed Table	39
Grounding Requirements	13	Checking Infeed Table	40
Extension Cords	13	Adjusting Table Parallelism	41
SECTION 3: SETUP	14	Setting Outfeed Table Height	43
Needed for Setup	14	Adjusting Infeed Table Stop Bolts	44
Unpacking	14	Calibrating Depth Scale	44
Inventory	15	Setting Fence Stops	45
Cleanup	16	Setting 45° Inward Fence Stop	45
Site Considerations	17	Setting 90° Fence Stop	45
Assembly	18	Setting 45° Outward Fence Stop	45
Dust Collection	23	SECTION 8: WIRING	46
Test Run	24	Wiring Safety Instructions	46
Recommended Adjustments	24	G0490/G0490X Wiring	47
SECTION 4: OPERATIONS	25	SECTION 9: PARTS	49
Operation Overview	25	Jointer Breakdown	49
Stock Inspection & Requirements	26	Stand Breakdown	52
Squaring Stock	27	Labels	54
Surface Planing	28	WARRANTY & RETURNS	57
Edge Jointing	29		
Bevel Cutting	30		
Rabbet Cutting	31		

INTRODUCTION

Machine Description

A jointer is used to flatten the face or edge of a workpiece, which is required when properly “squaring up” a workpiece for later construction or jointing. A jointer can also cut bevels, rabbets, and other specialized cuts with various jigs or fixtures.

A typical cut on a jointer is made by firmly holding a workpiece against the infeed table and fence, then moving the workpiece over the cutterhead while using the fence as a guide. As the workpiece moves over the cutterhead, the knives or inserts make many shallow cuts that “shave” off the surface of the workpiece. Since only a small amount of the workpiece is removed during a jointer cut, most jointer cuts are repeated many times to yield a desired result.

The Model G0490 has a 4-knife cutterhead and the Model G0490X has a spiral cutterhead with 40 indexable inserts.

Contact Info

We stand behind our machines! If you have questions or need help, contact us with the information below. Before contacting, make sure you get the **serial number** and **manufacture date** from the machine ID label. This will help us help you faster.

Grizzly Technical Support
1815 W. Battlefield
Springfield, MO 65807
Phone: (570) 546-9663
Email: techsupport@grizzly.com

We want your feedback on this manual. What did you like about it? Where could it be improved? Please take a few minutes to give us feedback.

Grizzly Documentation Manager
P.O. Box 2069
Bellingham, WA 98227-2069
Email: manuals@grizzly.com

Manual Accuracy

We are proud to provide a high-quality owner’s manual with your new machine!

We made every effort to be exact with the instructions, specifications, drawings, and photographs in this manual. Sometimes we make mistakes, but our policy of continuous improvement also means that **sometimes the machine you receive is slightly different than shown in the manual.**

If you find this to be the case, and the difference between the manual and machine leaves you confused or unsure about something, check our website for an updated version. We post current manuals and manual updates for free on our website at www.grizzly.com.

Alternatively, you can call our Technical Support for help. Before calling, make sure you write down the **Manufacture Date** and **Serial Number** from the machine ID label (see below). This information is required for us to provide proper tech support, and it helps us determine if updated documentation is available for your machine.

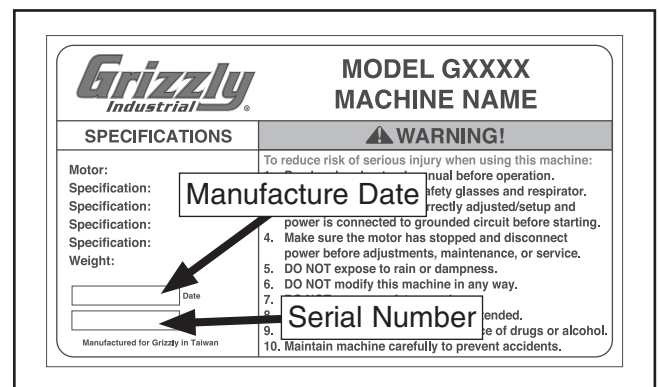

Identification

Become familiar with the names and locations of the controls and features shown below to better understand the instructions in this manual.

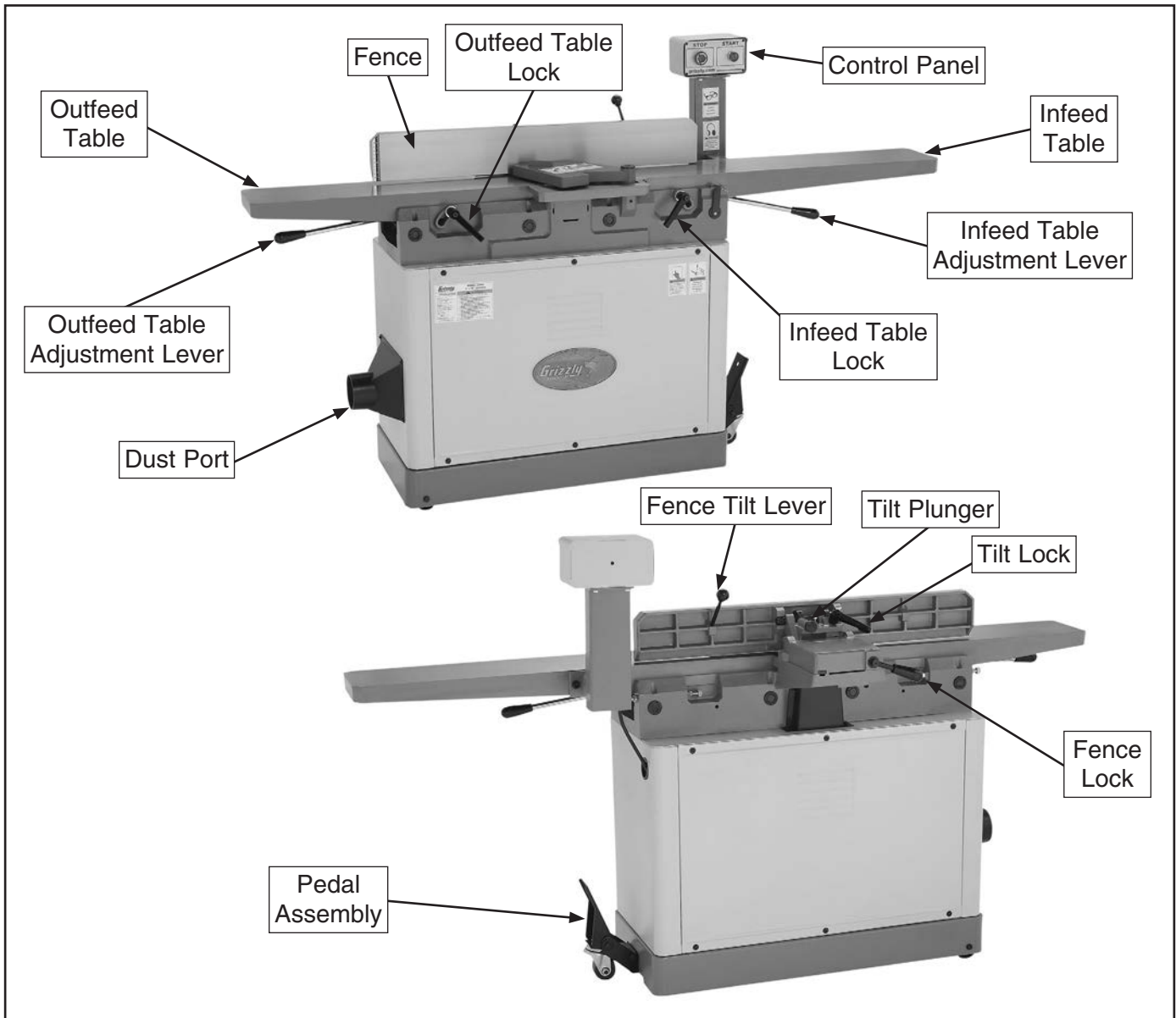

⚠️ WARNING

For Your Own Safety Read Instruction Manual Before Operating Jointer

- a) Wear eye protection.
- b) Always keep cutterhead and drive guards in place and in proper operating condition. **ALWAYS** replace cutterhead guard after rabbeting operations.
- c) Never make jointing or rabbeting cuts deeper than $\frac{1}{8}$ " or planing cuts deeper than $\frac{1}{16}$ "
- d) Always use hold-down or push blocks when jointing material narrower than 3" or planing material thinner than 3".
- e) Never perform jointing, planing, or rabbeting cuts on pieces shorter than 10" in length.



Controls & Components

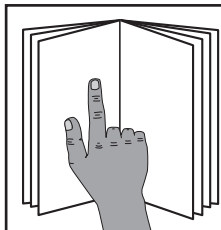

WARNING

To reduce your risk of serious injury, read this entire manual **BEFORE** using machine.

Refer to **Figures 1–3** and the following descriptions to become familiar with the basic controls of this machine.

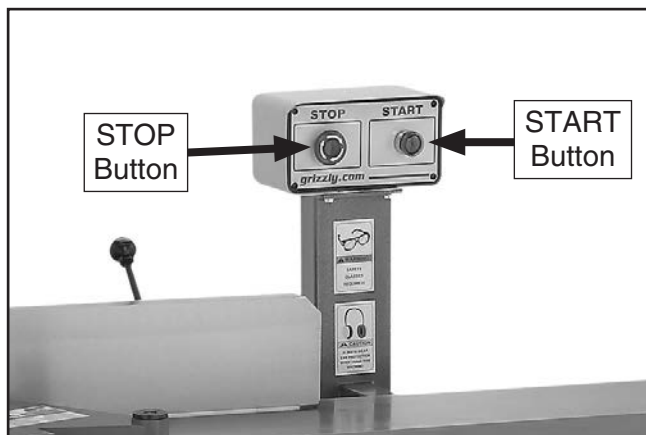

Figure 1. STOP/START button locations.

START Button: Starts motor only if the STOP button is in the out position.

STOP Button: Stops motor when pushed in and disables the START button. Enable the START button by twisting the STOP button clockwise until it springs forward in the out position.

Table Movement: To move the infeed table, loosen the table lock (see **Figure 2**), position the table with the table adjustment lever in the preset range, then tighten the table lock. The outfeed table is preset with no range of movement allowed, so if it gets accidentally unlocked it will not move.

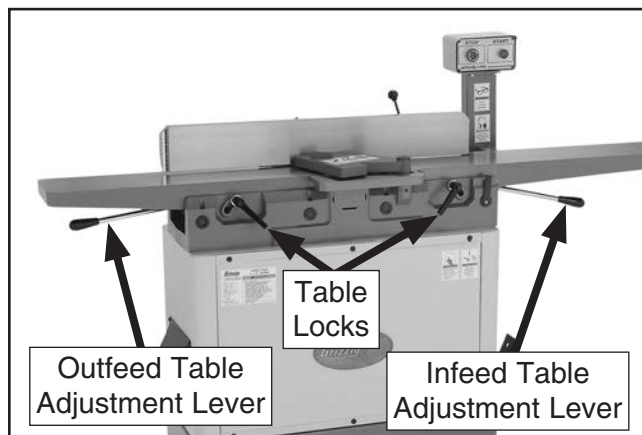

Figure 2. Locations of table locks and levers.

Fence Movement: The fence has a lock that keeps it in position (see **Figure 3**). To move the fence, loosen the lock and slide the fence where needed.

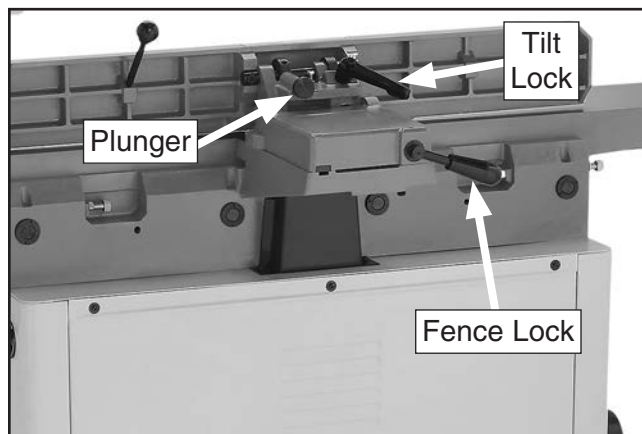

Figure 3. Locations of fence controls.

Fence Tilting: The tilt lock (see **Figure 3**) secures the fence at any position in the available range. The plunger locks into an indexing ring to easily set the fence tilt to 90° after moving it. Two positive stops enable the fence to be positioned at 45° inward and 45° outward for common 45° bevel cuts. Even when the fence is resting against the fence stops, the tilt lock must be tightened before cutting.





MACHINE DATA SHEET

Customer Service #: (570) 546-9663 · To Order Call: (800) 523-4777 · Fax #: (800) 438-5901

MODEL G0490 8" JOINTER WITH PARALLELOGRAM BEDS

Product Dimensions:

Weight..... 508 lbs.
 Width (side-to-side) x Depth (front-to-back) x Height..... 76-3/8 x 23-1/2 x 45-1/2 in.
 Footprint (Length x Width)..... 44-1/2 x 16-1/2 in.

Shipping Dimensions:

Carton #1

Type..... Wood Crate
 Content..... Machine
 Weight..... 402 lbs.
 Length x Width x Height..... 81 x 25 x 13 in.
 Must Ship Upright..... Yes

Carton #2

Type..... Cardboard Box
 Content..... Stand
 Weight..... 162 lbs.
 Length x Width x Height..... 38 x 18 x 28 in.
 Must Ship Upright..... No

Electrical:

Power Requirement..... 240V, Single-Phase, 60 Hz
 Prewired Voltage..... 240V
 Full-Load Current Rating..... 15A
 Minimum Circuit Size..... 20A
 Connection Type..... Cord & Plug
 Power Cord Included..... Yes
 Power Cord Length..... 6 ft.
 Power Cord Gauge..... 12 AWG
 Plug Included..... Yes
 Included Plug Type..... 6-20
 Switch Type..... Button Controls w/Magnetic Switch Protection

Motors:

Main

Horsepower..... 3 HP
 Phase..... Single-Phase
 Amps..... 15A
 Speed..... 3450 RPM
 Type..... TEFC Capacitor-Start Induction
 Power Transfer..... Belt Drive
 Bearings..... Sealed & Permanently Lubricated



Main Specifications:

Main Specifications

Jointer Size.....	8 in.
Bevel Jointing.....	0 – 45 deg. L/R
Maximum Width of Cut.....	8 in.
Maximum Depth of Cut.....	1/8 in.
Minimum Workpiece Length.....	10 in.
Minimum Workpiece Thickness.....	1/2 in.
Maximum Rabbeting Depth.....	1/2 in.
Number of Cuts Per Minute.....	19,200

Fence Information

Fence Length.....	36 in.
Fence Width.....	1-1/4 in.
Fence Height.....	5 in.
Fence Stops.....	45, 90, 135 deg.

Cutterhead Information

Cutterhead Type.....	4 Knife
Cutterhead Diameter.....	3-3/16 in.
Cutterhead Speed.....	4800 RPM

Knife Information

Number of Knives.....	4
Knife Type.....	HSS, Single-Sided
Knife Length.....	8 in.
Knife Width.....	3/4 in.
Knife Thickness.....	1/8 in.
Knife Adjustment.....	Jack Screws or Springs

Table Information

Table Length.....	76-3/8 in.
Table Width.....	8 in.
Table Thickness.....	1-1/2 in.
Floor to Table Height.....	32-5/8 in.
Table Adjustment Type.....	Lever Action
Table Movement Type.....	Parallelogram

Construction

Body Assembly.....	Cast Iron
Cabinet.....	Pre-formed Steel
Fence Assembly.....	Cast Iron
Guard.....	Die Cast Metal
Table.....	Precision Ground Cast Iron
Paint Type/Finish.....	Powder Coated

Other Information

Number of Dust Ports.....	1
Dust Port Size.....	4 in.
Mobile Base.....	Built-In

Other Specifications:

Country of Origin	China
Warranty	1 Year
Approximate Assembly & Setup Time	2 Hours
Serial Number Location	ID Label
ISO 9001 Factory	No
Certified by a Nationally Recognized Testing Laboratory (NRTL)	Yes





MACHINE DATA SHEET

Customer Service #: (570) 546-9663 · To Order Call: (800) 523-4777 · Fax #: (800) 438-5901

MODEL G0490X 8" JOINTER WITH PARALLELOGRAM BEDS AND SPIRAL CUTTERHEAD

Product Dimensions:

Weight..... 508 lbs.
 Width (side-to-side) x Depth (front-to-back) x Height..... 76-3/8 x 26-1/2 x 45-1/2 in.
 Footprint (Length x Width)..... 44-1/2 x 16-1/2 in.

Shipping Dimensions:

Carton #1

Type..... Wood Crate
 Content..... Machine
 Weight..... 394 lbs.
 Length x Width x Height..... 81 x 24 x 11 in.
 Must Ship Upright..... Yes

Carton #2

Type..... Cardboard Box
 Content..... Stand
 Weight..... 162 lbs.
 Length x Width x Height..... 38 x 18 x 28 in.
 Must Ship Upright..... No

Electrical:

Power Requirement..... 240V, Single-Phase, 60 Hz
 Prewired Voltage..... 240V
 Full-Load Current Rating..... 15A
 Minimum Circuit Size..... 20A
 Connection Type..... Cord & Plug
 Power Cord Included..... Yes
 Power Cord Length..... 6 ft.
 Power Cord Gauge..... 12 AWG
 Plug Included..... Yes
 Included Plug Type..... 6-20
 Switch Type..... Button Controls w/Magnetic Switch Protection

Motors:

Main

Horsepower..... 3 HP
 Phase..... Single-Phase
 Amps..... 15A
 Speed..... 3450 RPM
 Type..... TEFC Capacitor-Start Induction
 Power Transfer..... Belt Drive
 Bearings..... Sealed & Permanently Lubricated



Main Specifications:

Main Specifications

Jointer Size.....	8 in.
Bevel Jointing.....	0 – 45 deg. L/R
Maximum Width of Cut.....	8 in.
Maximum Depth of Cut.....	1/8 in.
Minimum Workpiece Length.....	10 in.
Minimum Workpiece Thickness.....	1/2 in.
Maximum Rabbeting Depth.....	1/2 in.
Number of Cuts Per Minute.....	19,200

Fence Information

Fence Length.....	36 in.
Fence Width.....	1-1/4 in.
Fence Height.....	5 in.
Fence Stops.....	45, 90, 135 deg.

Cutterhead Information

Cutterhead Type.....	Spiral
Cutterhead Diameter.....	3-3/8 in.
Number of Cutter Spirals.....	4
Number of Indexable Cutters.....	40
Cutterhead Speed.....	4800 RPM

Cutter Insert Information

Cutter Insert Type.....	Indexable Carbide
Cutter Insert Length.....	14 mm
Cutter Insert Width.....	14 mm
Cutter Insert Thickness.....	2 mm

Table Information

Table Length.....	76-3/8 in.
Table Width.....	8 in.
Table Thickness.....	1-1/2 in.
Floor to Table Height.....	32-5/8 in.
Table Adjustment Type.....	Lever Action
Table Movement Type.....	Parallelogram

Construction

Body Assembly.....	Cast Iron
Cabinet.....	Pre-formed Steel
Fence Assembly.....	Cast Iron
Guard.....	Die Cast Metal
Table.....	Precision Ground Cast Iron
Paint Type/Finish.....	Powder Coated

Other Information

Number of Dust Ports.....	1
Dust Port Size.....	4 in.
Mobile Base.....	Built-In

Other Specifications:

Country of Origin	China
Warranty	1 Year
Approximate Assembly & Setup Time	2 Hours
Serial Number Location	ID Label
ISO 9001 Factory	No
Certified by a Nationally Recognized Testing Laboratory (NRTL)	Yes



SECTION 1: SAFETY

For Your Own Safety, Read Instruction Manual Before Operating This Machine

The purpose of safety symbols is to attract your attention to possible hazardous conditions. This manual uses a series of symbols and signal words intended to convey the level of importance of the safety messages. The progression of symbols is described below. Remember that safety messages by themselves do not eliminate danger and are not a substitute for proper accident prevention measures. Always use common sense and good judgment.

 **DANGER** Indicates an imminently hazardous situation which, if not avoided, **WILL** result in death or serious injury.

 **WARNING** Indicates a potentially hazardous situation which, if not avoided, **COULD** result in death or serious injury.

 **CAUTION** Indicates a potentially hazardous situation which, if not avoided, **MAY** result in minor or moderate injury. It may also be used to alert against unsafe practices.

NOTICE This symbol is used to alert the user to useful information about proper operation of the machine.

Safety Instructions for Machinery

WARNING

OWNER'S MANUAL. Read and understand this owner's manual **BEFORE** using machine.

TRAINED OPERATORS ONLY. Untrained operators have a higher risk of being hurt or killed. Only allow trained/supervised people to use this machine. When machine is not being used, disconnect power, remove switch keys, or lock-out machine to prevent unauthorized use—especially around children. Make your workshop kid proof!

DANGEROUS ENVIRONMENTS. Do not use machinery in areas that are wet, cluttered, or have poor lighting. Operating machinery in these areas greatly increases the risk of accidents and injury.

MENTAL ALERTNESS REQUIRED. Full mental alertness is required for safe operation of machinery. Never operate under the influence of drugs or alcohol, when tired, or when distracted.

ELECTRICAL EQUIPMENT INJURY RISKS. You can be shocked, burned, or killed by touching live electrical components or improperly grounded machinery. To reduce this risk, only allow qualified service personnel to do electrical installation or repair work, and always disconnect power before accessing or exposing electrical equipment.

DISCONNECT POWER FIRST. Always disconnect machine from power supply **BEFORE** making adjustments, changing tooling, or servicing machine. This prevents an injury risk from unintended startup or contact with live electrical components.

EYE PROTECTION. Always wear ANSI-approved safety glasses or a face shield when operating or observing machinery to reduce the risk of eye injury or blindness from flying particles. Everyday eyeglasses are **NOT** approved safety glasses.



WARNING

WEARING PROPER APPAREL. Do not wear clothing, apparel or jewelry that can become entangled in moving parts. Always tie back or cover long hair. Wear non-slip footwear to reduce risk of slipping and losing control or accidentally contacting cutting tool or moving parts.

HAZARDOUS DUST. Dust created by machinery operations may cause cancer, birth defects, or long-term respiratory damage. Be aware of dust hazards associated with each workpiece material. Always wear a NIOSH-approved respirator to reduce your risk.

HEARING PROTECTION. Always wear hearing protection when operating or observing loud machinery. Extended exposure to this noise without hearing protection can cause permanent hearing loss.

REMOVE ADJUSTING TOOLS. Tools left on machinery can become dangerous projectiles upon startup. Never leave chuck keys, wrenches, or any other tools on machine. Always verify removal before starting!

USE CORRECT TOOL FOR THE JOB. Only use this tool for its intended purpose—do not force it or an attachment to do a job for which it was not designed. Never make unapproved modifications—modifying tool or using it differently than intended may result in malfunction or mechanical failure that can lead to personal injury or death!

AWKWARD POSITIONS. Keep proper footing and balance at all times when operating machine. Do not overreach! Avoid awkward hand positions that make workpiece control difficult or increase the risk of accidental injury.

CHILDREN & BYSTANDERS. Keep children and bystanders at a safe distance from the work area. Stop using machine if they become a distraction.

GUARDS & COVERS. Guards and covers reduce accidental contact with moving parts or flying debris. Make sure they are properly installed, undamaged, and working correctly **BEFORE** operating machine.

FORCING MACHINERY. Do not force machine. It will do the job safer and better at the rate for which it was designed.

NEVER STAND ON MACHINE. Serious injury may occur if machine is tipped or if the cutting tool is unintentionally contacted.

STABLE MACHINE. Unexpected movement during operation greatly increases risk of injury or loss of control. Before starting, verify machine is stable and mobile base (if used) is locked.

USE RECOMMENDED ACCESSORIES. Consult this owner's manual or the manufacturer for recommended accessories. Using improper accessories will increase the risk of serious injury.

UNATTENDED OPERATION. To reduce the risk of accidental injury, turn machine **OFF** and ensure all moving parts completely stop before walking away. Never leave machine running while unattended.

MAINTAIN WITH CARE. Follow all maintenance instructions and lubrication schedules to keep machine in good working condition. A machine that is improperly maintained could malfunction, leading to serious personal injury or death.

DAMAGED PARTS. Regularly inspect machine for damaged, loose, or mis-adjusted parts—or any condition that could affect safe operation. Immediately repair/replace **BEFORE** operating machine. For your own safety, **DO NOT** operate machine with damaged parts!

MAINTAIN POWER CORDS. When disconnecting cord-connected machines from power, grab and pull the plug—**NOT** the cord. Pulling the cord may damage the wires inside. Do not handle cord/plug with wet hands. Avoid cord damage by keeping it away from heated surfaces, high traffic areas, harsh chemicals, and wet/damp locations.

EXPERIENCING DIFFICULTIES. If at any time you experience difficulties performing the intended operation, stop using the machine! Contact our Technical Support at (570) 546-9663.



Additional Safety for Jointers

WARNING

Serious cuts, amputation, entanglement, or death can occur from contact with rotating cutterhead or other moving components! Flying chips can cause blindness or eye injuries. Workpieces or inserts/knives thrown by cutterhead can strike nearby operator or bystanders with deadly force. To reduce the risk of these hazards, operator and bystanders MUST completely heed the hazards and warnings below.

KICKBACK. Occurs when workpiece is ejected from machine at a high rate of speed. To reduce the risk of kickback-related injuries, use quality workpieces, safe feeding techniques, and proper machine setup or maintenance.

GUARD REMOVAL. Operating jointer without guard exposes operator to knives/inserts. Except when rabbeting, never remove guards for regular operations or while connected to power. Turn jointer **OFF** and disconnect power before clearing any shavings or sawdust from around cutterhead. After rabbeting or maintenance is complete, immediately replace all guards and ensure they are properly adjusted before resuming regular operations.

DULL/DAMAGED KNIVES/INSERTS. Dull knives/inserts can increase risk of kickback and cause poor workpiece finish. Only use sharp, undamaged knives/inserts.

OUTFEED TABLE ALIGNMENT. Setting outfeed table too high can cause workpiece to hit table and get stuck, increasing risk of kickback. Setting outfeed table too low may cause workpiece to become tapered from front to back. Always keep outfeed table even with knives/inserts at top dead center (highest point during rotation).

INSPECTING STOCK. Impact injuries or fire may result from using poor workpieces. Thoroughly inspect and prepare workpiece before cutting. Verify workpiece is free of nails, staples, loose knots or other foreign material. Workpieces with minor warping should be surface planed first with cupped side facing infeed table.

GRAIN DIRECTION. Jointing against the grain or end grain can increase the risk of kickback. It also requires more cutting force, which produces chatter or excessive chip out. Always joint or surface plane **WITH** the grain.

MAXIMUM CUTTING DEPTH. To reduce risk of kickback, never cut deeper than $\frac{1}{8}$ " per pass.

CUTTING LIMITATIONS. Cutting a workpiece that does not meet the minimum dimension requirements can result in breakup, kickback, or accidental contact with cutterhead during operation. Never perform jointing, planing, or rabbeting cuts on pieces smaller than 8" long, $\frac{3}{4}$ " wide, or $\frac{1}{4}$ " thick.

PUSH BLOCKS. Not using push blocks when surface planing may result in accidental cutterhead contact. Always use push blocks when planing materials less than 3" high or wide. Never pass your hands directly over cutterhead without a push block.

WORKPIECE SUPPORT. Loss of workpiece control while feeding can increase risk of kickback or accidental contact with cutterhead. Support workpiece continuously during operation. Position and guide workpiece with fence. Support long or wide stock with auxiliary stands.

FEED WORKPIECE PROPERLY. Kickback or accidental cutterhead contact may result if workpiece is fed into cutterhead the wrong way. Allow cutterhead to reach full speed before feeding. Never start jointer with workpiece touching cutterhead. Always feed workpiece from infeed side to outfeed side without stopping until cut is complete. Never back work toward infeed table.

SECURE KNIVES/INSERTS. Loose knives or improperly set inserts can become dangerous projectiles or cause machine damage. Always verify knives/inserts are secure and properly adjusted before operation. Straight knives should never project more than $\frac{1}{8}$ " (0.125") from cutterhead body.



SECTION 2: POWER SUPPLY

Availability

Before installing the machine, consider the availability and proximity of the required power supply circuit. If an existing circuit does not meet the requirements for this machine, a new circuit must be installed. To minimize the risk of electrocution, fire, or equipment damage, installation work and electrical wiring must be done by an electrician or qualified service personnel in accordance with all applicable codes and standards.

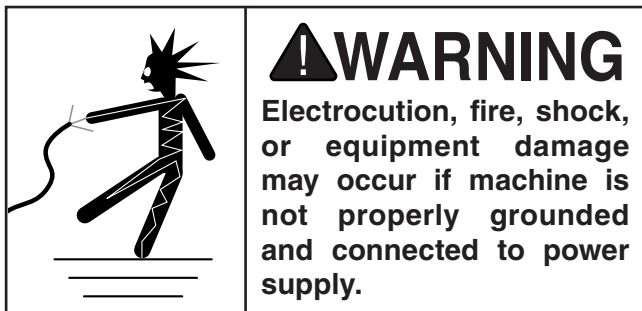

Full-Load Current Rating

The full-load current rating is the amperage a machine draws at 100% of the rated output power. On machines with multiple motors, this is the amperage drawn by the largest motor or sum of all motors and electrical devices that might operate at one time during normal operations.

Full-Load Current Rating at 240V 15 Amps

The full-load current is not the maximum amount of amps that the machine will draw. If the machine is overloaded, it will draw additional amps beyond the full-load rating.

If the machine is overloaded for a sufficient length of time, damage, overheating, or fire may result—especially if connected to an undersized circuit. To reduce the risk of these hazards, avoid overloading the machine during operation and make sure it is connected to a power supply circuit that meets the specified circuit requirements.

Circuit Information

A power supply circuit includes all electrical equipment between the breaker box or fuse panel in the building and the machine. The power supply circuit used for this machine must be sized to safely handle the full-load current drawn from the machine for an extended period of time. (If this machine is connected to a circuit protected by fuses, use a time delay fuse marked D.)

! CAUTION
For your own safety and protection of property, consult an electrician if you are unsure about wiring practices or electrical codes in your area.

Note: *Circuit requirements in this manual apply to a dedicated circuit—where only one machine will be running on the circuit at a time. If machine will be connected to a shared circuit where multiple machines may be running at the same time, consult an electrician or qualified service personnel to ensure circuit is properly sized for safe operation.*

Circuit Requirements

This machine is prewired to operate on a power supply circuit that has a verified ground and meets the following requirements:

Nominal Voltage 208V, 220V, 230V, 240V
Cycle 60 Hz
Phase Single-Phase
Power Supply Circuit 20 Amps
Plug/Receptacle NEMA 6-20



Grounding Requirements

This machine **MUST** be grounded. In the event of certain malfunctions or breakdowns, grounding reduces the risk of electric shock by providing a path of least resistance for electric current.

This machine is equipped with a power cord that has an equipment-grounding wire and a grounding plug. Only insert plug into a matching receptacle (outlet) that is properly installed and grounded in accordance with all local codes and ordinances. **DO NOT** modify the provided plug!

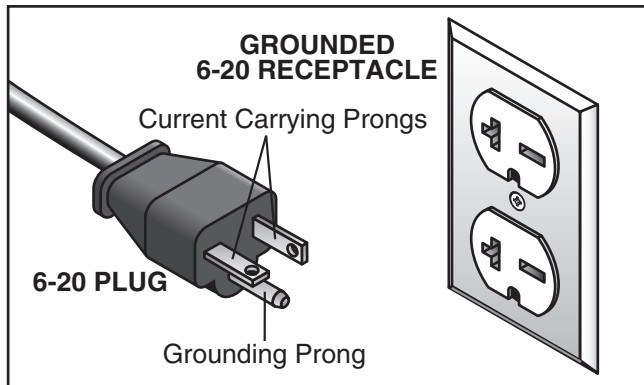
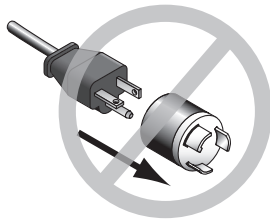

Figure 4. Typical 6-20 plug and receptacle.

CAUTION



No adapter should be used with plug. If plug does not fit available receptacle, or if machine must be reconnected for use on a different type of circuit, reconnection must be performed by an electrician or qualified service personnel, and it must comply with all local codes and ordinances.

WARNING

Serious injury could occur if you connect machine to power before completing setup process. DO NOT connect to power until instructed later in this manual.

Improper connection of the equipment-grounding wire can result in a risk of electric shock. The wire with green insulation (with or without yellow stripes) is the equipment-grounding wire. If repair or replacement of the power cord or plug is necessary, do not connect the equipment-grounding wire to a live (current carrying) terminal.

Check with a qualified electrician or service personnel if you do not understand these grounding requirements, or if you are in doubt about whether the tool is properly grounded. If you ever notice that a cord or plug is damaged or worn, disconnect it from power, and immediately replace it with a new one.

Extension Cords

We do not recommend using an extension cord with this machine. If you must use an extension cord, only use it if absolutely necessary and only on a temporary basis.

Extension cords cause voltage drop, which can damage electrical components and shorten motor life. Voltage drop increases as the extension cord size gets longer and the gauge size gets smaller (higher gauge numbers indicate smaller sizes).

Any extension cord used with this machine must be in good condition and contain a ground wire and matching plug/receptacle. Additionally, it must meet the following size requirements:

Minimum Gauge Size 12 AWG
Maximum Length (Shorter is Better).....50 ft.



SECTION 3: SETUP

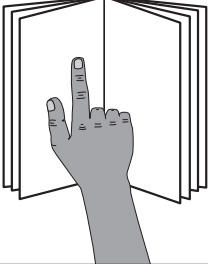

!WARNING
This machine presents serious injury hazards to untrained users. Read through this entire manual to become familiar with the controls and operations before starting the machine!



!WARNING
Wear safety glasses during the entire setup process!



!WARNING
HEAVY LIFT!
Straining or crushing injury may occur from improperly lifting machine or some of its parts. To reduce this risk, get help from other people and use a forklift (or other lifting equipment) rated for weight of this machine.



!WARNING
SUFFOCATION HAZARD!
Keep children and pets away from plastic bags or packing materials shipped with this machine. Discard immediately.

Needed for Setup

The following are needed to complete the setup process:

Description	Qty
• Additional People	1
• Safety Glasses	1 Per Person
• Cleaner/Degreaser (Page 16)	As Needed
• Disposable Shop Rags.....	As Needed
• Lifting Equipment (At Least 750 lb. Rating):	
—Forklift or Hoist	1
—Lifting Straps.....	2
• Wrench or Socket 13mm.....	1
• Wrenches or Sockets 17mm	2
• Wrench or Socket 10mm.....	1
• Straightedge 4'	1
• Screwdriver Phillips #2	1
• Screwdriver Flat Head #2.....	1
• Dust Collection System	1
• Dust Hose 4"	1
• Hose Clamps 4"	2

Unpacking

This machine was carefully packaged for safe transport. When unpacking, separate all enclosed items from packaging materials and inspect them for shipping damage. ***If items are damaged, please call us immediately at (570) 546-9663.***

IMPORTANT: Save all packaging materials until you are completely satisfied with the machine and have resolved any issues between Grizzly or the shipping agent. ***You MUST have the original packaging to file a freight claim. It is also extremely helpful if you need to return your machine later.***



Inventory

The following is a list of items shipped with your machine. Before beginning setup, lay these items out and inventory them.

If any non-proprietary parts are missing (e.g. a nut or a washer), we will gladly replace them; or for the sake of expediency, replacements can be obtained at your local hardware store.

Inventory: (Figures 5–6)	Qty
A. Jointer Assembly	1
B. Fence Carriage.....	1
C. Fence.....	1
D. Cutterhead Guard.....	1
E. Fence Tilt Lever.....	1
F. General Tools:	
—Wrench 8/10mm.....	1
—Wrench 12/14mm.....	1
—Hex Wrenches 2.5, 4, 5, 6, 8mm... 1 Each	
G. Push Blocks.....	2
H. Stand w/Motor	1
I. Control Panel Pedestal Assembly	1
J. Pedal Assembly.....	1
K. Belt Guard	1
L. Poly V-Belt 8PK-1172.....	1
M. Dust Port	1

Hardware Bag (Not Shown):

• Carriage Bolts M8-1.25 x 25 (Motor)	2
• Flat Washers 8mm (Motor).....	2
• Hex Nuts M8-1.25 (Motor)	2
• Hex Bolt M8-1.25 x 50 (Wheel/Stand).....	1
• Flat Washer 8mm (Wheel/Stand)	1
• Hex Bolts M10-1.5 x 55 (Wheel/Stand)	2
• Flat Washers 10mm (Wheel/Stand)	2
• Hex Nuts M10-1.5 (Wheel/Stand).....	2
• Cap Screws M8-1.25 x 25 (Jointer/Stand)..	8
• Lock Washers 8mm (Jointer/Stand)	8
• Cap Screws M10-1.5 x 25 (Pedestal)	2
• Lock Washers 10mm (Pedestal)	2
• Flange Bolts M6-1 x 10 (Belt Guard).....	2
• Flat Washers 6mm (Belt Guard).....	2
• Hex Nuts M6-1 (Belt Guard).....	2

G0490 Knife Setting Gauge (Not Shown):

• External Retaining Rings 8mm.....	2
• Knife Gauge Feet	2
• Knife Gauge Rod.....	1

G0490X Cutterhead Hardware (Not Shown):

- Driver Bits Torx T20..... 2
- L-Wrenches Torx T20
- Flat Hd Torx Screws T20 M6-1 x 15..... 3
- Indexable Carbide Inserts 14 x 14 x 2mm.. 5

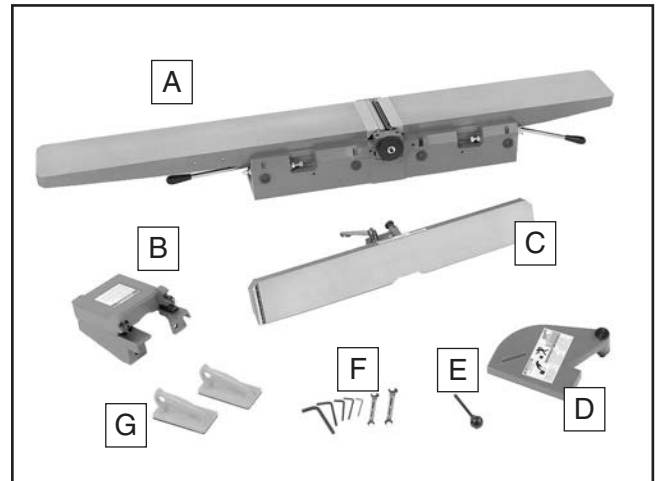

Figure 5. G0490/G0490X inventory—box 1.

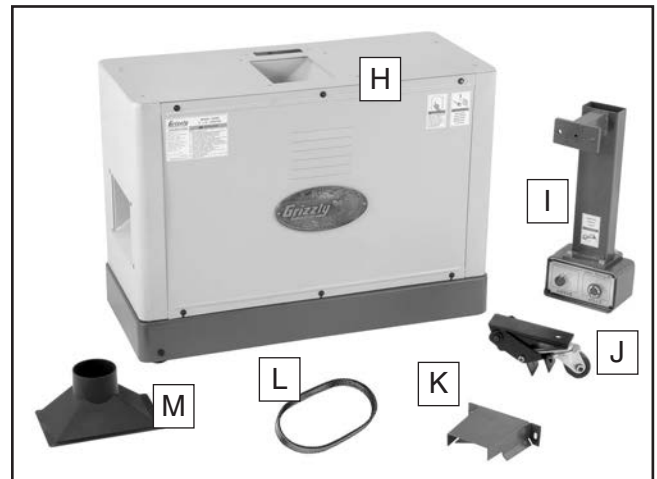

Figure 6. G0490/G0490X inventory—box 2.

NOTICE

If you cannot find an item on this list, carefully check around/inside the machine and packaging materials. Often, these items get lost in packaging materials while unpacking or they are pre-installed at the factory.



Cleanup

The unpainted surfaces of your machine are coated with a heavy-duty rust preventative that prevents corrosion during shipment and storage. This rust preventative works extremely well, but it will take a little time to clean.

Be patient and do a thorough job cleaning your machine. The time you spend doing this now will give you a better appreciation for the proper care of your machine's unpainted surfaces.

There are many ways to remove this rust preventative, but the following steps work well in a wide variety of situations. Always follow the manufacturer's instructions with any cleaning product you use and make sure you work in a well-ventilated area to minimize exposure to toxic fumes.

Before cleaning, gather the following:

- Disposable rags
- Cleaner/degreaser (WD-40 works well)
- Safety glasses & disposable gloves
- Plastic paint scraper (optional)

Basic steps for removing rust preventative:

1. Put on safety glasses.
2. Coat the rust preventative with a liberal amount of cleaner/degreaser, then let it soak for 5–10 minutes.
3. Wipe off the surfaces. If your cleaner/degreaser is effective, the rust preventative will wipe off easily. If you have a plastic paint scraper, scrape off as much as you can first, then wipe off the rest with the rag.
4. Repeat **Steps 2–3** as necessary until clean, then coat all unpainted surfaces with a quality metal protectant to prevent rust.

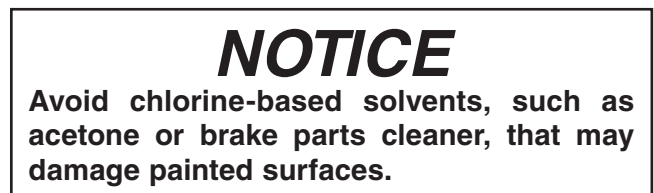
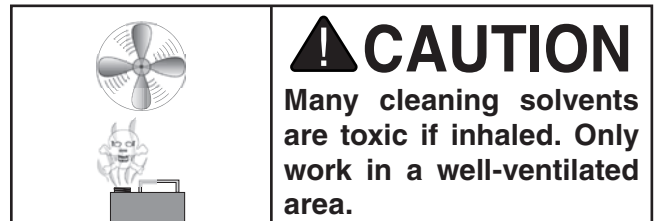
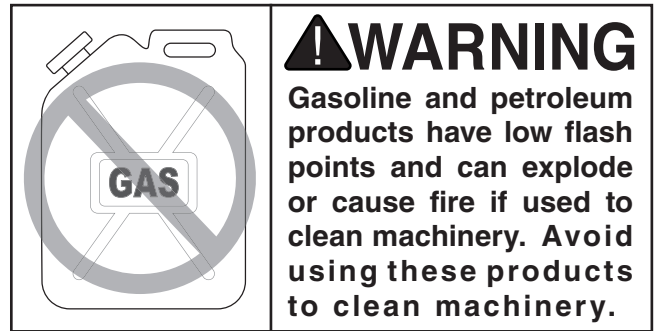

T23692—Orange Power Degreaser

A great product for removing the waxy shipping grease from your machine during clean up.



Figure 7. T23692 Orange Power Degreaser.



Site Considerations

Weight Load

Refer to the **Machine Data Sheet** for the weight of your machine. Make sure that the surface upon which the machine is placed will bear the weight of the machine, additional equipment that may be installed on the machine, and the heaviest workpiece that will be used. Additionally, consider the weight of the operator and any dynamic loading that may occur when operating the machine.

Space Allocation

Consider the largest size of workpiece that will be processed through this machine and provide enough space around the machine for adequate operator material handling or the installation of auxiliary equipment. With permanent installations, leave enough space around the machine to open or remove doors/covers as required by the maintenance and service described in this manual. **See below for required space allocation.**

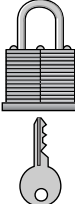
	<p>CAUTION Children or untrained people may be seriously injured by this machine. Only install in an access restricted location.</p>
---	---

Physical Environment

The physical environment where the machine is operated is important for safe operation and longevity of machine components. For best results, operate this machine in a dry environment that is free from excessive moisture, hazardous chemicals, airborne abrasives, or extreme conditions. Extreme conditions for this type of machinery are generally those where the ambient temperature range exceeds 41°–104°F; the relative humidity range exceeds 20%–95% (non-condensing); or the environment is subject to vibration, shocks, or bumps.

Electrical Installation

Place this machine near an existing power source. Make sure all power cords are protected from traffic, material handling, moisture, chemicals, or other hazards. Make sure to leave enough space around machine to disconnect power supply or apply a lockout/tagout device, if required.

Lighting

Lighting around the machine must be adequate enough that operations can be performed safely. Shadows, glare, or strobe effects that may distract or impede the operator must be eliminated.

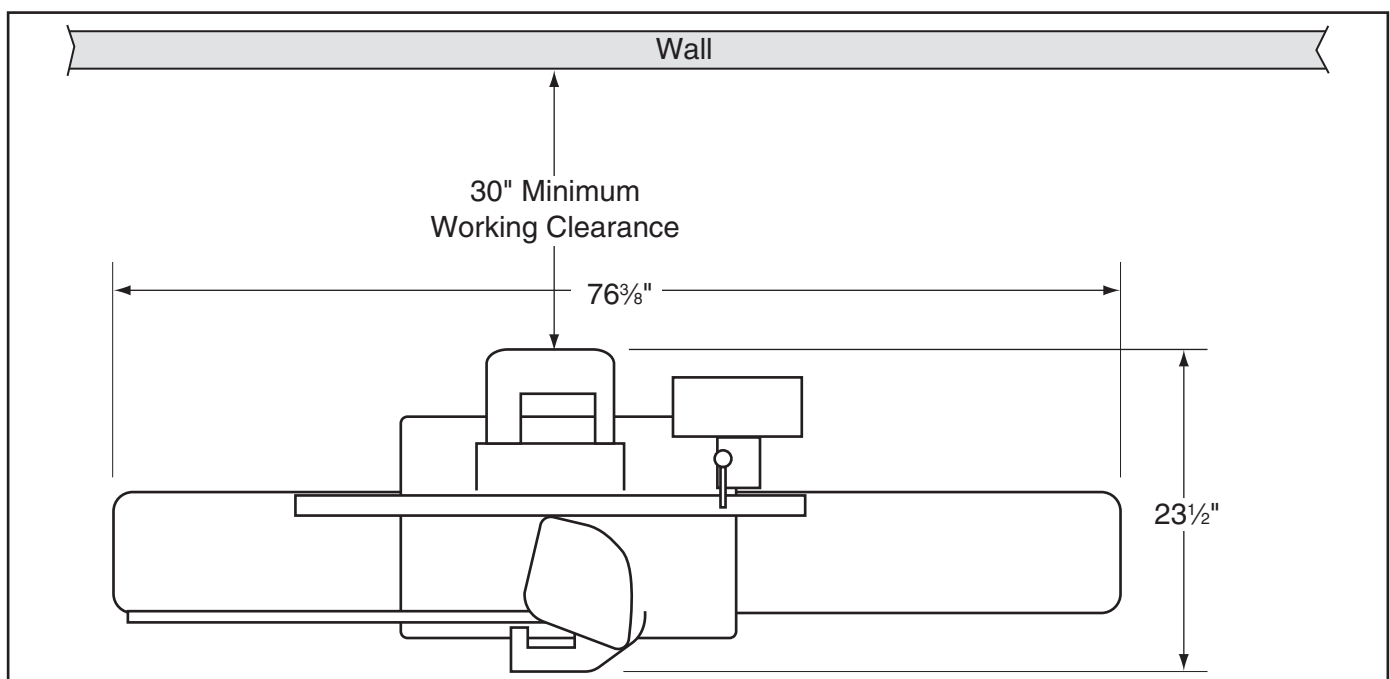

Figure 8. Minimum working clearances.



Assembly

To properly prepare your jointer for operation, complete all of the steps in the assembly procedure prior to performing the **Test Run** on **Page 24**.

To assemble your jointer:

1. With help of another person, tip stand shipping box upside down, then lift shipping box off stand.
2. Place a piece of cardboard on floor, tip stand over so stand top is on cardboard, then remove plastic from stand.
3. Reach inside stand and remove accessories box, poly V-belt, and dust port.
4. Unbolt control panel pedestal from inside stand and set it off to the side.
5. Remove rear stand panel.
6. Reach inside stand and remove the (2) M8-1.25 x 25 hex nuts and (2) 8mm flat washers that secure motor to cabinet top.

Note: Retain the two carriage bolts, hex nuts, and flat washers so that they can be used to install motor in a later step.

7. Using cardboard to protect stand and another person to hold motor, place the stand on its left side so that dust chute is face down on floor.
8. Place motor on the two motor mount brackets with pulley facing rear of stand, as shown in **Figure 9**.

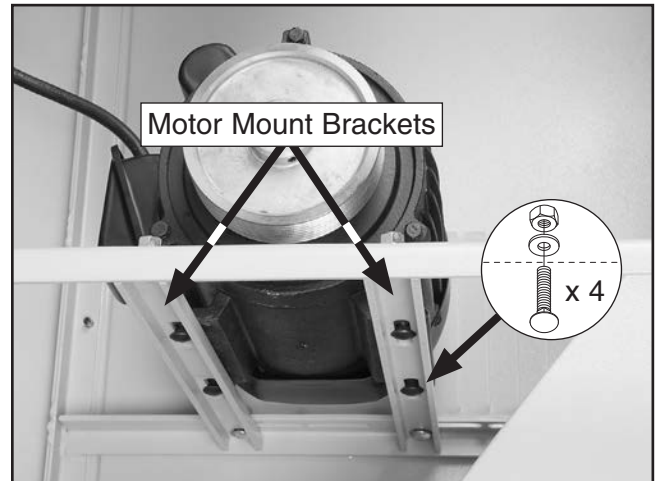

Figure 9. Motor installed.

9. Attach motor to motor mount brackets with (4) M8-1.25 x 25 carriage bolts, (4) 8mm flat washers, and (4) M8-1.25 hex nuts (two sets from inventory and two sets that were removed in **Step 6**), as shown in **Figure 9**.

Note: Pulley alignment and V-belt installation will take place in later steps.

10. Attach pedal assembly to right side of stand with (1) M8-1.25 x 50 hex bolt, (2) M8-1.25 x 55 hex bolts, (3) 8mm flat washers, and (2) M8-1.25 hex nuts, as shown in **Figure 10**.

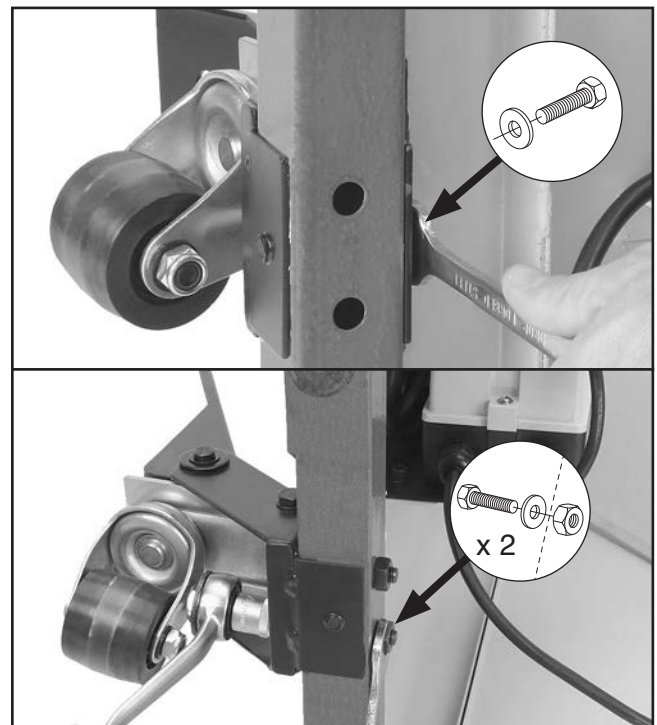

Figure 10. Installing the pedal assembly.



11. From inside stand, insert power cord plug through the same hole in stand that control panel pedestal cord is in.
12. With help of another person, place stand upright.
13. Attach dust port to stand with pre-installed Phillips screws and flat washers, as shown in **Figure 11**.

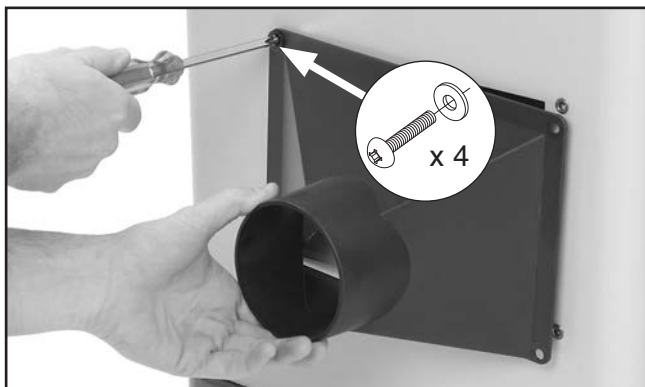

Figure 11. Installing dust port.

14. Remove the (2) hex nuts and flat washers from underneath shipping crate that hold the jointer assembly to the crate.
15. Wrap lifting straps around infeed and outfeed table, as illustrated in **Figure 12**, then attach them to forklift forks or hoist.

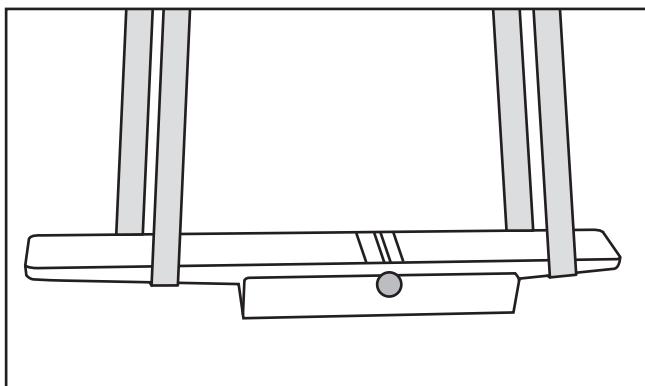

Figure 12. Using lifting straps to lift jointer assembly.

16. With another person to steady load, carefully lift jointer assembly over stand and align the eight mounting holes in stand with holes in bottom of jointer assembly.

Note: Make sure the cutterhead pulley is facing to the rear of the stand.

17. Attach jointer assembly to the stand with (8) M8-1.25 x 25 cap screws and (8) 8mm lock washers, as shown in **Figure 13**.



Figure 13. Securing the jointer assembly to the stand.

18. Attach control panel pedestal to back of the infeed table with (2) M10-1.5 x 25 cap screws and (2) 10mm lock washers, as shown in **Figure 14**.

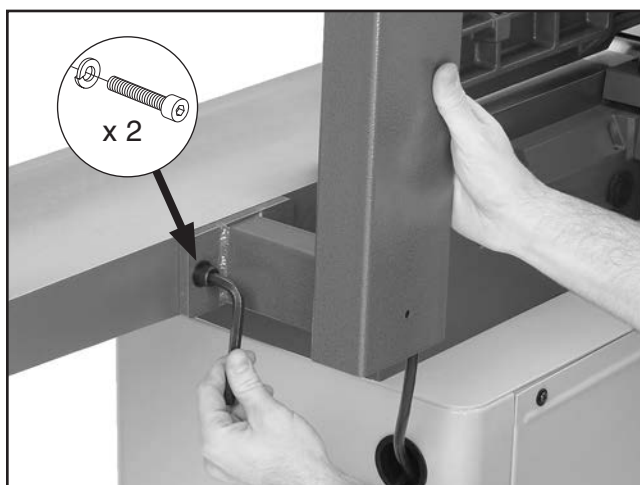

Figure 14. Installing control panel pedestal.



19. Visually check alignment of cutterhead and motor pulleys, as illustrated in **Figure 15**.

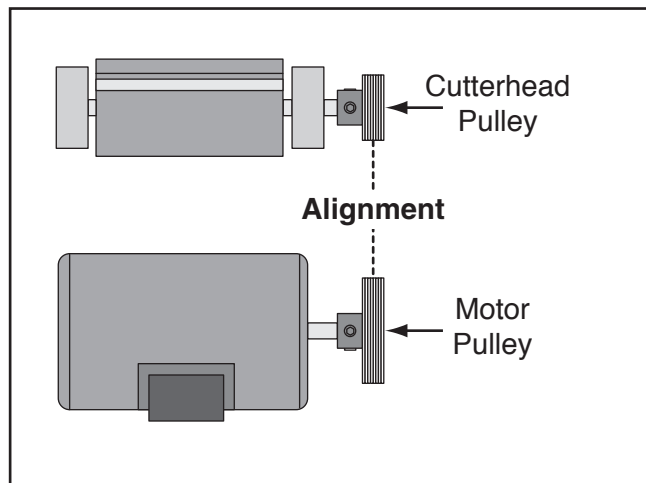

Figure 15. Pulleys aligned.

—If they are not aligned, loosen the four mounting carriage bolts shown in **Figure 16**, shift motor horizontally to align pulleys, then retighten carriage bolts.

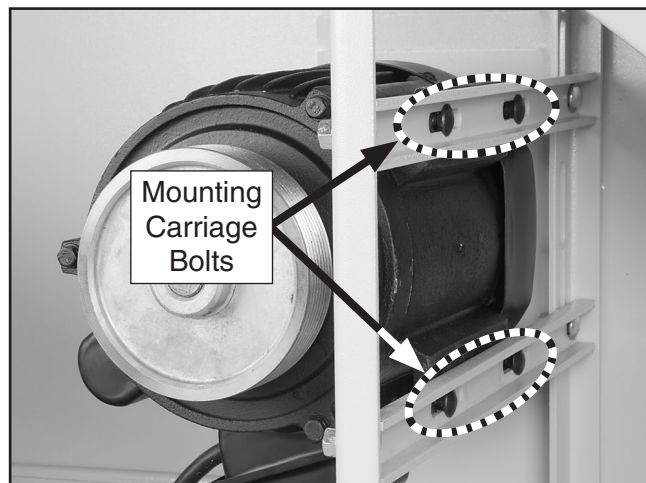

Figure 16. Motor adjustment controls.

20. Use the two pre-installed cap screws and flat washers to install fence carriage to rear of jointer assembly, as shown in **Figure 17**.

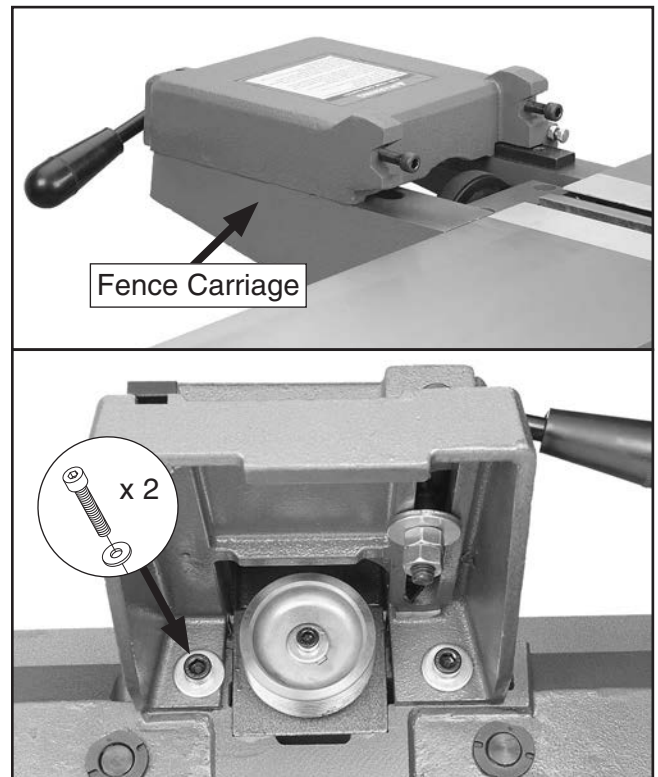

Figure 17. Fence carriage installed.

21. Wrap poly V-belt around cutterhead and motor pulleys, as shown in **Figure 18**. Make sure ribs of V-belt are seated in pulley grooves.

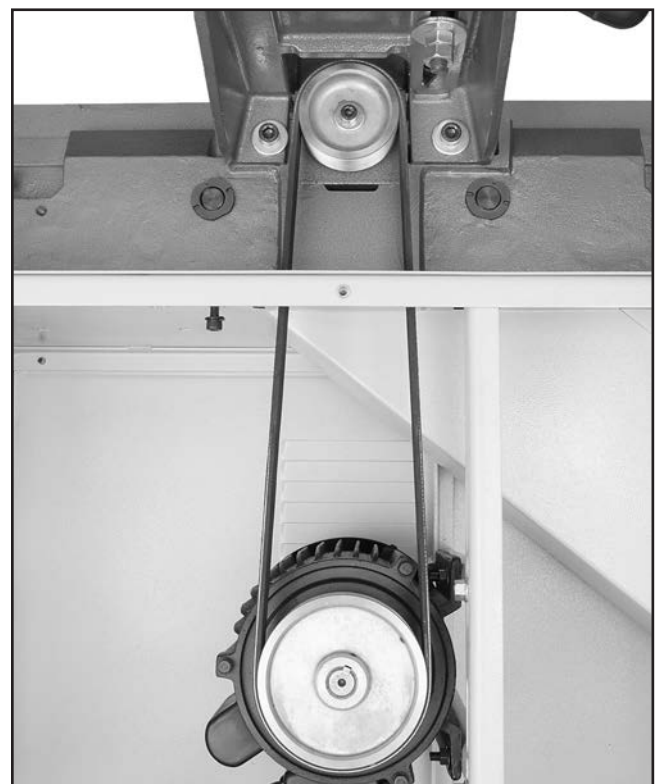

Figure 18. Poly V-belt installed.



22. Loosen carriage bolts securing motor mounting brackets (see **Figure 19**), let motor slide down to tension V-belt, then retighten carriage bolts.

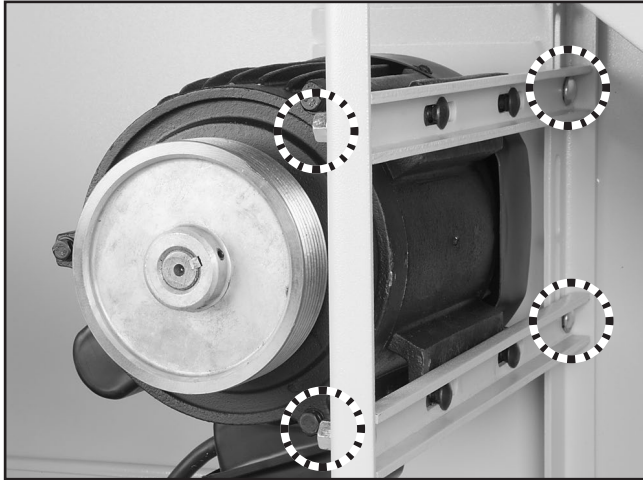

Figure 19. Motor mounting carriage bolts.

Note: When properly tensioned, there is approximately $\frac{1}{4}$ " deflection of V-belt as moderate pressure is applied midway between the pulleys, as illustrated in **Figure 20**. If necessary, apply downward pressure on motor to attain proper V-belt tension.

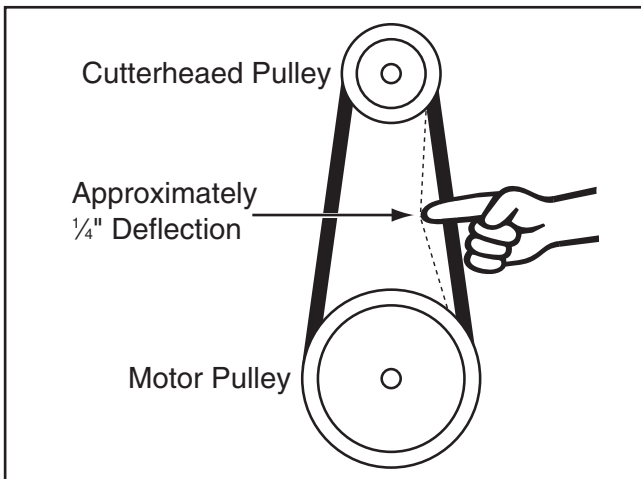

Figure 20. Correct V-belt deflection when properly tensioned.

23. Use the two pre-installed cap screws on fence carriage to install fence, as shown in **Figure 21**.

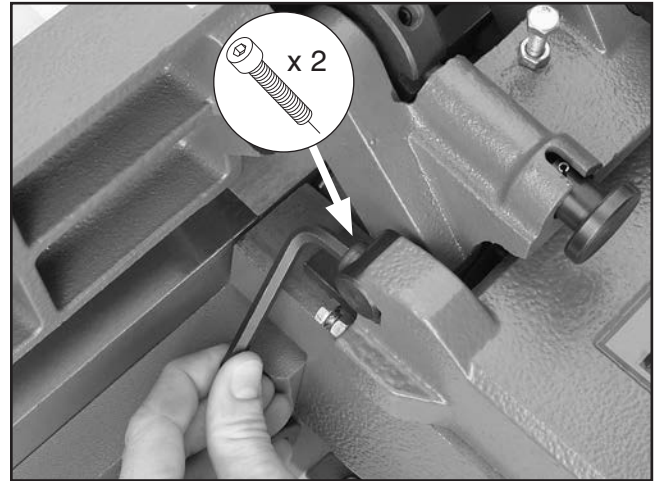

Figure 21. Installing fence.

24. Install fence tilt lever, as shown in **Figure 22**.

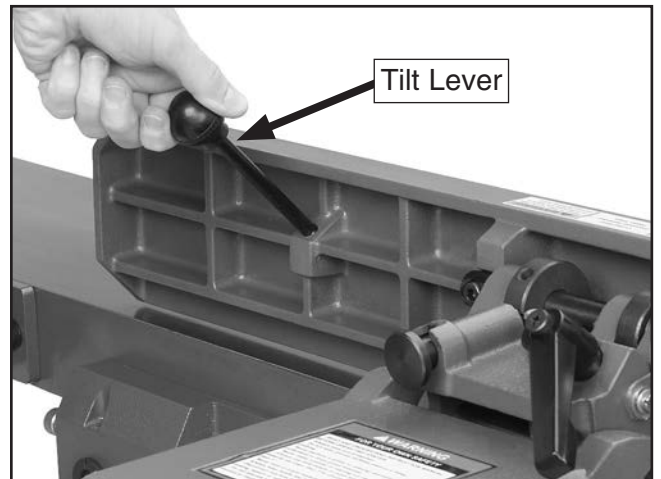

Figure 22. Installing fence tilt lever.



!WARNING

The outfeed table **MUST** be level with cutterhead knives or inserts when they are at top dead center (their highest point during rotation). Otherwise, the workpiece cannot properly feed past the cutterhead, which may cause a kickback hazard to the operator.

25. Place straightedge on outfeed table so it extends over cutterhead.
26. Use cutterhead pulley to rotate cutterhead until one of the knives or inserts is at top dead center (their highest point during rotation), as illustrated in **Figures 23–24**.

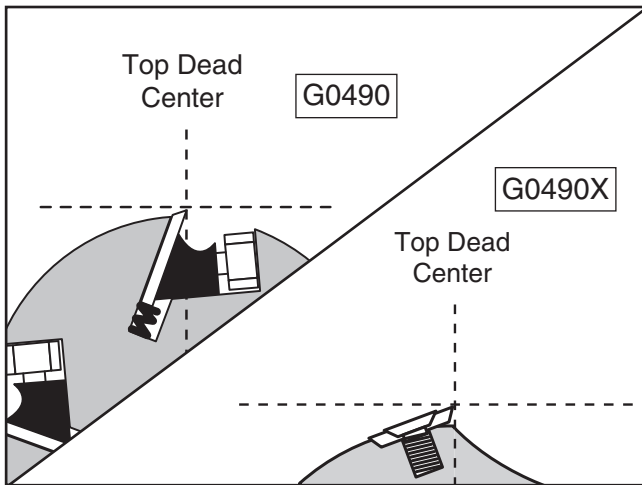

Figure 23. Knife or insert at top dead center.

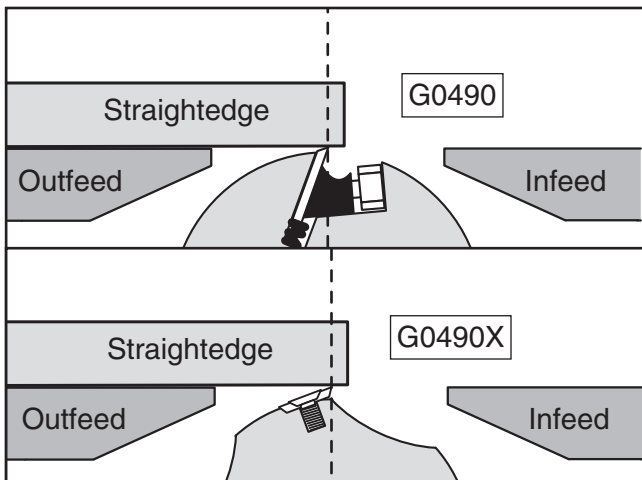

Figure 24. Using straightedge to check outfeed table height.

When the outfeed table height is correctly set, the knife or insert at top dead center will barely touch the straightedge, as illustrated in **Figure 24**.

—If knife or insert lifts straightedge off table or is below straightedge, then outfeed table height must be reset (refer to **Setting Outfeed Table Height** on **Page 43** for detailed instructions).

!CAUTION

Belt guard MUST be installed before operating jointer or else moving V-belt will be exposed, creating an entanglement hazard at back of jointer.

27. Use (2) M6-1 x 10 flange bolts, (2) 8mm flat washers, and (2) M6-1 hex nuts to install belt guard underneath the fence carriage, as shown in **Figure 25**.

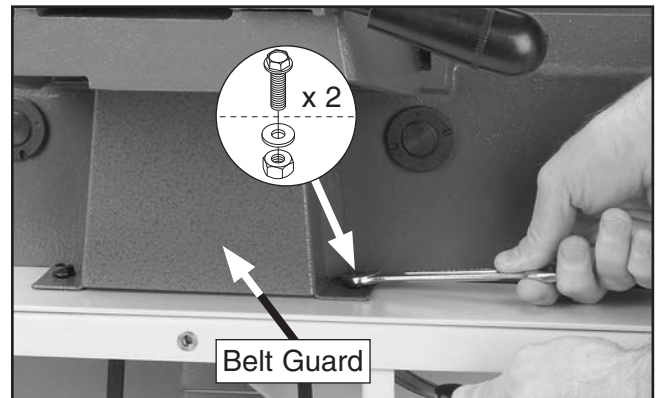

Figure 25. Installing belt guard.

28. **Model G0490 Only:** Assemble knife setting gauge, as shown in **Figure 26**.



Figure 26. Knife setting gauge assembled.



29. Re-install rear stand panel.
30. Move fence back as far as you can to make room for cutterhead guard.
31. Insert cutterhead guard shaft into extension fence, as shown in **Figure 27**, so shaft flat is facing set screw, then tighten set screw against shaft.

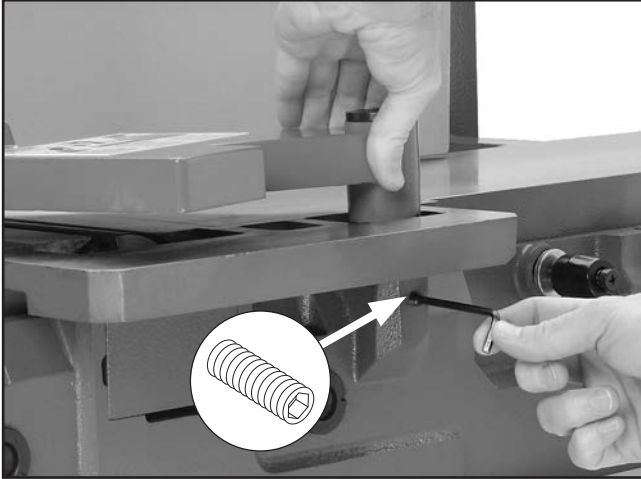

Figure 27. Installing cutterhead guard.

32. Test operation of guard by pulling it back and letting go. Guard should spring back over cutterhead.
 - If guard drags across table, loosen set screw, raise guard slightly so that it does not drag, then retighten set screw.
 - If the guard does not spring back over cutterhead, re-install it and make sure flat part of guard shaft faces set screw.

Dust Collection

⚠ CAUTION

DO NOT operate Model G0490/G0490X without an adequate dust collection system. This jointer creates substantial amounts of wood dust while operating. Failure to use a dust collection system can result in short and long-term respiratory illness.

Recommended CFM at Dust Port: 400 CFM
Do not confuse this CFM recommendation with the rating of the dust collector. To determine the CFM at the dust port, you must consider these variables: (1) CFM rating of the dust collector, (2) hose type and length between the dust collector and the machine, (3) number of branches or wyes, and (4) amount of other open lines throughout the system. Explaining how to calculate these variables is beyond the scope of this manual. Consult an expert or purchase a good dust collection "how-to" book.

To connect a dust collection hose:

1. Fit 4" dust hose over dust port on left side of stand and secure in place with a hose clamp.
2. Tug hose to make sure it does not come off.

Note: *A tight fit is necessary for proper performance.*



Test Run

Once assembly is complete, test run the machine to ensure it is properly connected to power and safety components are functioning correctly.

If you find an unusual problem during the test run, immediately stop the machine, disconnect it from power, and fix the problem **BEFORE** operating the machine again. The **Troubleshooting** table in the **SERVICE** section of this manual can help.

!WARNING

Serious injury or death can result from using this machine **BEFORE** understanding its controls and related safety information. **DO NOT** operate, or allow others to operate, machine until the information is understood.

!WARNING

DO NOT start machine until all preceding setup instructions have been performed. Operating an improperly set up machine may result in malfunction or unexpected results that can lead to serious injury, death, or machine/property damage.

To test run machine:

1. Push STOP button in (see **Figure 28**).

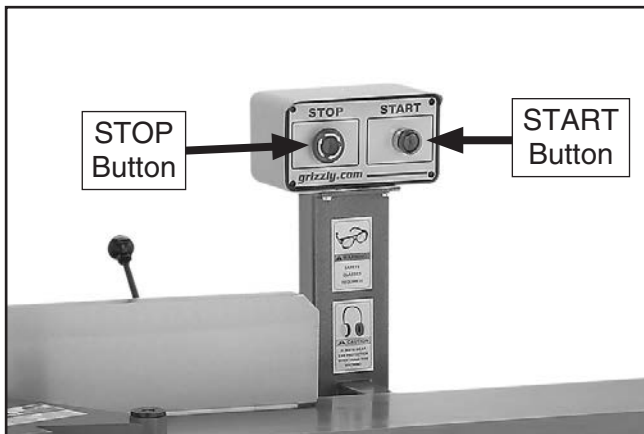

Figure 28. STOP/START button locations.

2. Connect machine to power source by inserting power cord plug into a matching receptacle.
3. Twist STOP button clockwise until it pops out. This resets button so machine will start.
4. Push START button to turn machine **ON**. A correctly operating machine runs smoothly with little or no vibration or rubbing noises.
5. Press STOP button to turn machine **OFF**.
6. **WITHOUT** resetting STOP button, press START button. Machine should not start.

—If machine *does not* start, the STOP button safety feature is working correctly. Congratulations! The Test Run is complete.

—If machine *does* start (with STOP button pushed in), immediately disconnect power to machine. The STOP button safety feature is not working correctly. This safety feature must work properly before proceeding with regular operations. Call Tech Support for help.

Recommended Adjustments

For your convenience, the adjustments listed below have been performed at the factory and no further setup is required to operate your machine. However, because of the many variables involved with shipping, we recommend that you at least verify the following adjustments to ensure the best possible results from your new machine.

Factory adjustments that should be verified:

- Model G0490 Knife Settings (refer to **Page 37**).
- Depth Scale Calibration (refer to **Page 44**).
- Fence Stop Accuracy (refer to **Page 45**).
- Table Parallelism (refer to **Page 39**).



SECTION 4: OPERATIONS

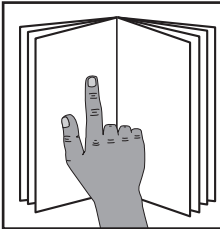

!WARNING

To reduce your risk of serious injury, read this entire manual **BEFORE** using machine.

!WARNING

Damage to your eyes, lungs, and ears could result from using this machine without proper protective gear. Always wear safety glasses, a respirator, and hearing protection when operating this machine.

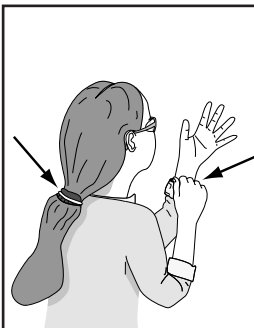
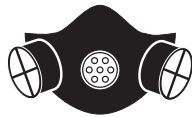

!WARNING

Loose hair, clothing, or jewelry could get caught in machinery and cause serious personal injury. Keep these items away from moving parts at all times to reduce this risk.

NOTICE

If you have never used this type of machine or equipment before, **WE STRONGLY RECOMMEND** that you read books, review industry trade magazines, or get formal training before beginning any projects. Regardless of the content in this section, Grizzly Industrial will not be held liable for accidents caused by lack of training.

Operation Overview

This overview covers the basic process that happens during a typical operation with this machine. Familiarize yourself with this process to better understand the controls and procedures explained throughout the **Operations** section.

To complete a typical operation with the jointer, the operator does the following:

1. Examines workpiece to verify it is safe and suitable for cutting.
2. Adjusts fence for width of workpiece and locks it in place.
3. Adjusts fence tilt, if necessary.
4. Adjusts infeed table height to set depth of cut per pass.
5. Puts on safety glasses, respirator, and ear protection.
6. Starts jointer.
7. Using push blocks as needed, holds workpiece firmly against infeed table and fence, and slides it into cutterhead at a steady and controlled rate until entire length of workpiece has advanced beyond cutterhead to outfeed table.
8. Repeats cutting process until desired results are achieved.
9. Stops jointer.



Stock Inspection & Requirements

Follow these rules when choosing and jointing stock:

- **DO NOT joint or surface plane stock that contains large or loose knots.** Injury to the operator or damage to the workpiece can occur if a knot becomes dislodged during the cutting operation.
- **Jointing and surface planing with the grain is safer for the operator and produces a better finish.** Cutting against the grain increases the likelihood of kickback and workpiece tear-out. **DO NOT** cut against the grain! Cutting with the grain is feeding the stock across the cutterhead so the grain points down and back, as viewed from the front edge of the stock (see **Figure 29**).

Note: If the grain changes direction along the edge of the workpiece, decrease the depth of cut and make additional passes.

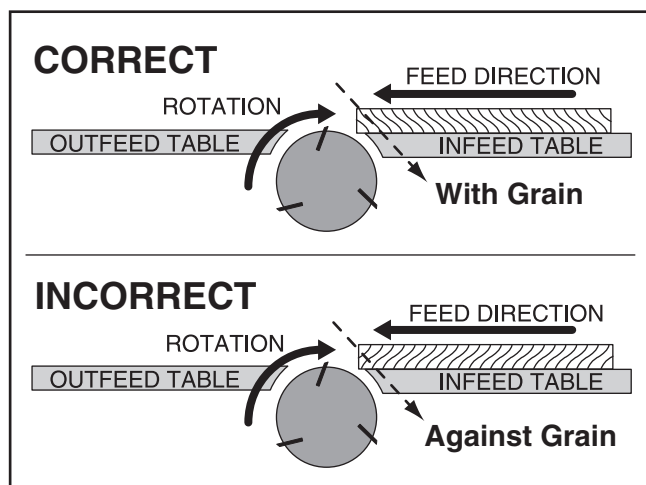

Figure 29. Proper grain alignment with the cutterhead.

- **Only process natural wood fiber through your jointer.** Your jointer is designed to cut only natural wood stock. This machine is NOT designed to cut metal, glass, stone, tile, products with lead-based paint, or products that contain asbestos—cutting these materials with a jointer may lead to injury.

- **Scrape all glue off the workpiece before jointing.** Glue deposits on the workpiece, hard or soft, will gum up the cutterhead and produce poor results.
- **Remove foreign objects from the workpiece.** Make sure that any stock you process with the jointer is clean and free of dirt, nails, staples, tiny rocks or any other foreign objects, that could damage the cutterhead. These particles could also cause a spark as they strike the cutterhead and create a fire hazard.

Note: Wood stacked on a concrete or dirt surface can have small pieces of concrete or stone pressed into the surface.

- **Make sure all stock is sufficiently dried before jointing.** Wood with a moisture content over 20% will cause unnecessary wear on the cutters and poor cutting results. Excess moisture can also hasten rust and corrosion.
- **Make sure your workpiece exceeds the minimum dimension requirements, as shown in Figure 30, before processing it through the jointer, or the workpiece may break or kickback during the operation.**

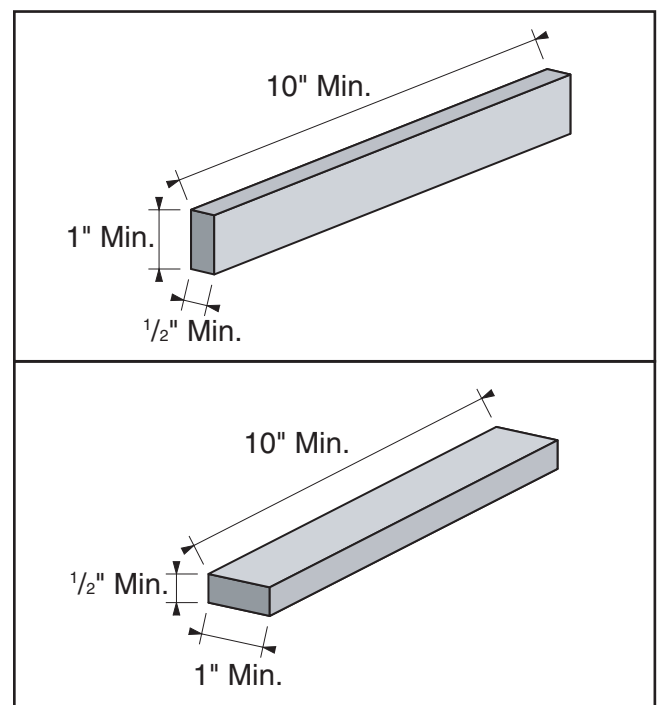

Figure 30. Minimum stock dimensions for jointer.



Squaring Stock

Squaring stock involves four steps performed in the order below:

1. **Surface Plane on Jointer**—Concave face of workpiece is surface planed flat with jointer.

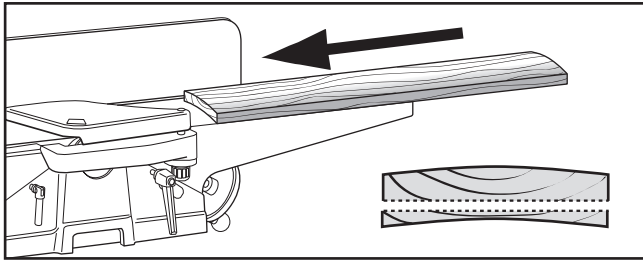

2. **Surface Plane on a Thickness Planer**—Opposite face of workpiece is surface planed flat with a thickness planer.

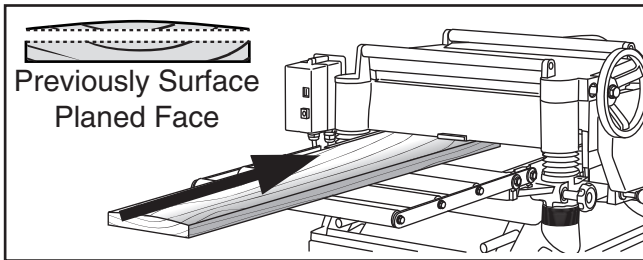

3. **Edge Joint on Jointer**—Concave edge of workpiece is jointed flat with jointer.

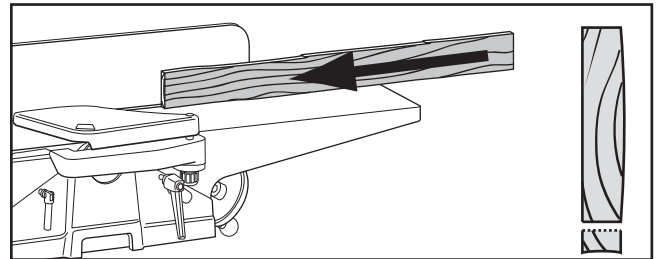

4. **Rip Cut on a Table Saw**—Jointed edge of workpiece is placed against a table saw fence and opposite edge cut off.

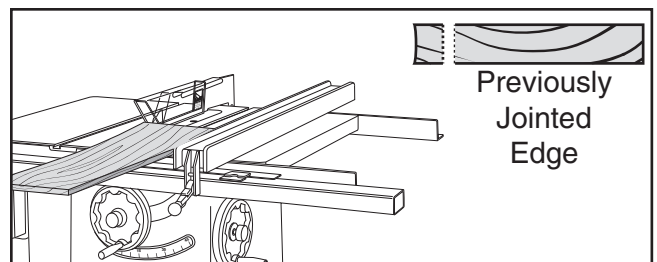

NOTICE

If you are not experienced with a jointer, set depth of cut to 0" and practice feeding workpiece across the tables as described for each of the jointing procedures. This process will better prepare you for actual operation.

Surface Planing

The purpose of surface planing (see **Figures 31–32**) on the jointer is to make one flat face on a piece of stock to prepare it for thickness planing on a planer.



Figure 31. Example of surface planing operations.

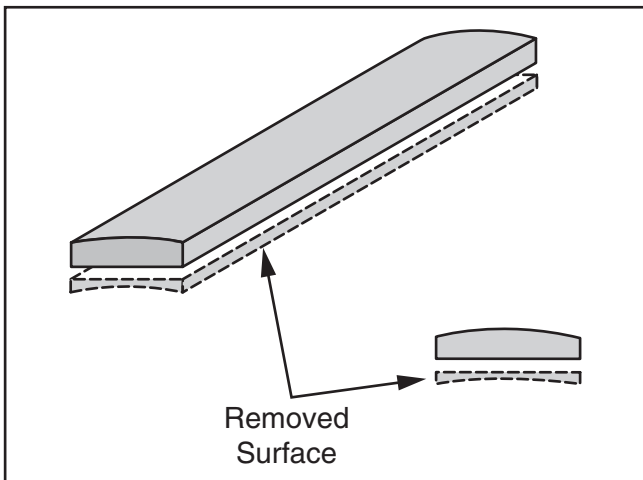

Figure 32. Illustration of surface planing results.

To surface plane on jointer:

1. Inspect stock to ensure it is safe and suitable for the operation (see **Stock Inspection & Requirements** section).
2. Set infeed table height to desired cutting depth for each pass.

IMPORTANT: To minimize risk of kickback, do not exceed a cutting depth of $\frac{1}{16}$ " per pass when surface planing.

3. Set fence to 90° .
4. Start jointer.
5. Place workpiece firmly against fence and infeed table.

IMPORTANT: To ensure workpiece remains stable during cut, concave sides of workpiece must face toward table and fence.

6. Feed workpiece completely across cutterhead while keeping it firmly against fence and tables during the entire cut.

IMPORTANT: Keep hands at least 4" away from cutterhead during the entire cut. Instead of allowing a hand to pass directly over cutterhead, lift it up and over cutterhead, and safely reposition it on the outfeed side to continue supporting workpiece. Use push blocks whenever practical to further reduce risk of accidental hand contact with cutterhead.

7. Repeat **Step 6** until entire surface is flat.

Tip: When squaring up stock, cut opposite side of workpiece with a planer instead of the jointer to ensure both sides are parallel.

⚠ WARNING

Failure to use push blocks when surface planing could result in your hands contacting rotating cutterhead, which will cause serious personal injury. **ALWAYS** use push blocks when surface planing on jointer!



Edge Jointing

Edge jointing (see **Figures 33–34**) produces a flat and true surface along the side of a workpiece by removing uneven areas. It is an essential step for squaring up warped or rough stock and when preparing a workpiece for joinery or finishing.



Figure 33. Example of edge jointing operation.

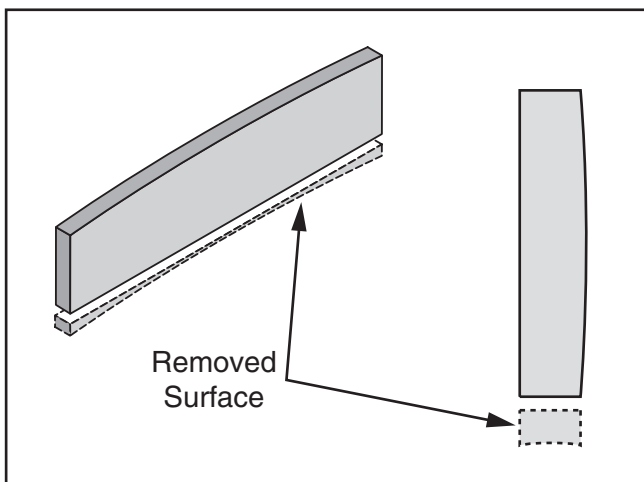

Figure 34. Illustration of edge jointing results.

To edge joint on jointer:

1. Inspect stock to ensure it is safe and suitable for the operation (see **Stock Inspection & Requirements** section).
2. Set infeed table height to desired cutting depth for each pass.

IMPORTANT: To minimize risk of kickback, do not exceed a cutting depth of $\frac{1}{8}$ " per pass.

3. Set fence to 90° .
4. Start jointer.
5. Place workpiece firmly against fence and infeed table.

IMPORTANT: To ensure workpiece remains stable during cut, concave sides of workpiece must face toward table and fence.

6. Feed workpiece completely across cutterhead while keeping it firmly against fence and tables during the entire cut.

IMPORTANT: Keep hands at least 4" away from cutterhead during the entire cut. Instead of allowing a hand to pass directly over cutterhead, lift it up and over cutterhead, and safely reposition it on the outfeed side to continue supporting workpiece. Use push blocks whenever practical to further reduce risk of accidental hand contact with cutterhead.

7. Repeat **Step 6** until the entire edge is flat.

Tip: When squaring up stock, cut opposite edge of workpiece with a table saw instead of the jointer—otherwise, both edges of workpiece will not be parallel with each other.



Bevel Cutting

Bevel cuts (see **Figures 35–36**) can be made by setting the fence at the desired angle and feeding the workpiece firmly along the fence face, with the bottom inside corner firmly against the table. The cutting process typically requires multiple passes or cuts to bevel the entire edge of a workpiece.



Figure 35. Fence setup for a bevel cut of 45°.

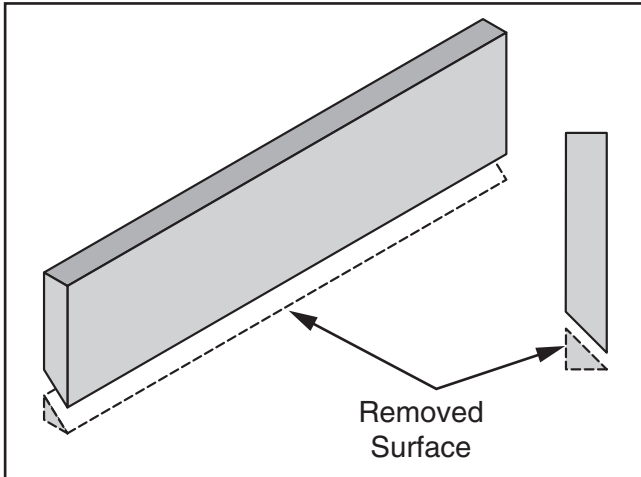

Figure 36. Illustration of bevel cutting results.

To bevel cut on jointer:

1. Inspect stock to ensure it is safe and suitable for the operation (see **Stock Inspection & Requirements** section).
2. Set infeed table height to cutting depth desired for each pass.

IMPORTANT: *Cutting depth for bevel cuts is typically between $\frac{1}{16}$ " and $\frac{1}{8}$ ", depending on hardness and width of stock.*

3. Set fence tilt to desired angle of cut.
4. Place workpiece against fence and infeed table with concave side face down.
5. Start jointer.
6. With a push block in your leading hand, press workpiece against table and fence with firm pressure, and feed workpiece over cutterhead with a push block in your trailing hand.

Note: *When your leading hand gets within 4" of the cutterhead, lift it up and over cutterhead, and place push block on portion of the workpiece once it is 4" past cutterhead. Now, focus your pressure on outfeed end of the workpiece while feeding, and repeat same action with your trailing hand when it gets within 4" of cutterhead. To help keep your hands safe, DO NOT let them get closer than 4" from moving cutterhead at any time during operation!*

7. Repeat cutting process, as necessary, until you are satisfied with the results.



Rabbet Cutting

The purpose of rabbet cutting (see **Figures 37–38**) is to remove a section of the workpiece edge, as shown below. When combined with another rabbet cut edge, the rabbet joints create a simple, yet strong method of joining stock.

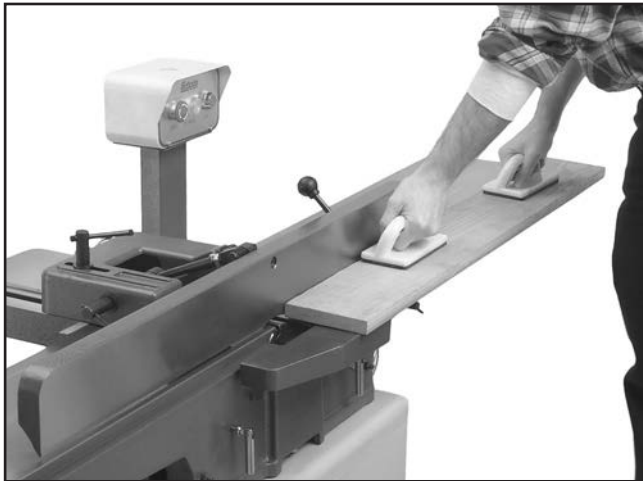

Figure 37. Typical rabbet cutting operation.

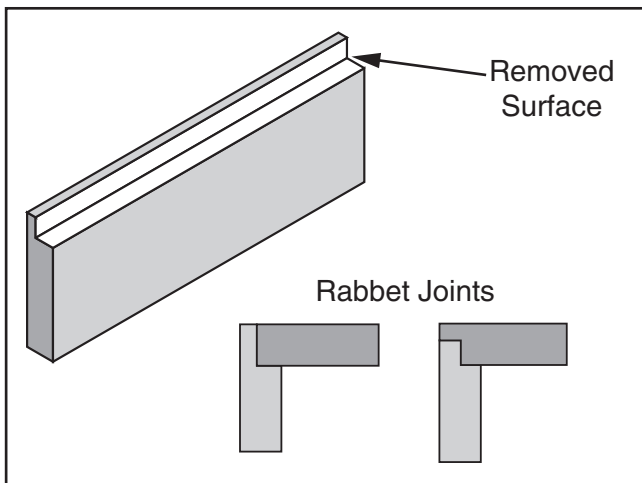

Figure 38. Illustration of rabbet cutting effects and a few sample joints.

To rabbet cut on jointer:

1. Inspect stock to ensure it is safe and suitable for the operation (see **Stock Inspection & Requirements** section).
2. Set infeed table height to desired cutting depth for each pass.

IMPORTANT: For safety reasons, cutting depth should never exceed $\frac{1}{8}$ " per pass.

3. Remove cutterhead guard.
4. Set fence to 90° and near front of jointer, so amount of exposed cutterhead in front of fence matches size of desired rabbet.
5. Start jointer.
6. Place workpiece firmly against fence and infeed table.

IMPORTANT: To ensure workpiece remains stable during cut, concave sides of workpiece must face toward table and fence.

7. Feed workpiece completely across cutterhead while keeping it firmly against fence and tables during entire cut.

IMPORTANT: Keep hands at least 4" away from cutterhead during the entire cut. Instead of allowing a hand to pass directly over cutterhead, lift it up and over cutterhead, and safely reposition it on the outfeed side to continue supporting workpiece. Use push blocks whenever practical to further reduce risk of accidental hand contact with cutterhead.

8. Repeat **Step 7** until rabbet is cut to depth.

!WARNING

When cutterhead guard is removed, attempting any other cut besides a rabbet directly exposes operator to moving cutterhead. **ALWAYS** replace cutterhead guard after rabbet cutting!



SECTION 5: ACCESSORIES

!WARNING

Installing unapproved accessories may cause machine to malfunction, resulting in serious personal injury or machine damage. To reduce this risk, only install accessories recommended for this machine by Grizzly.

NOTICE

Refer to our website or latest catalog for additional recommended accessories.

T21151—8" SELF-TEST® HSS System
 H5143—8" SELF-TEST® Cobalt System
 (Includes 1 Set Knife Holders & 4 Double-Edge HSS "Dispoz-A-Blade" Knives)

Knife changes are as easy as snapping the disposable double-edge knife onto the SELF-TEST® holder and sliding the holder and knife into the knife pocket until the precisely located stops contact the outside surface of your jointer's cutterhead. The time it takes to change knives has now been reduced to the time needed to loosen the cutterhead gib bolts, replace the dull edge and re-tighten. Unique to the industry, the SELF-TEST® knife installs in your ordinary stock cutterhead eliminating the need to buy and install a special costly cutterhead, which is required by every other quick change knife system!



Figure 39. Dispoz-A-Blade® Holder and Knife.

H2499—Small Half-Mask Respirator
 H3631—Medium Half-Mask Respirator
 H3632—Large Half-Mask Respirator
 H3635—Cartridge Filter Pair P100

Wood dust has been linked to nasal cancer and severe respiratory illnesses. If you work around dust everyday, a half-mask respirator can be a lifesaver. Also compatible with safety glasses!



Figure 40. Half-mask respirator with disposable cartridge filters.

Recommended Metal Protectants

G5562—SLIPIT® 1 Qt. Gel
 G5563—SLIPIT® 12 Oz. Spray
 G2871—Boeshield® T-9 12 Oz. Spray
 G2870—Boeshield® T-9 4 Oz. Spray
 H3788—G96® Gun Treatment 12 Oz. Spray
 H3789—G96® Gun Treatment 4.5 Oz. Spray

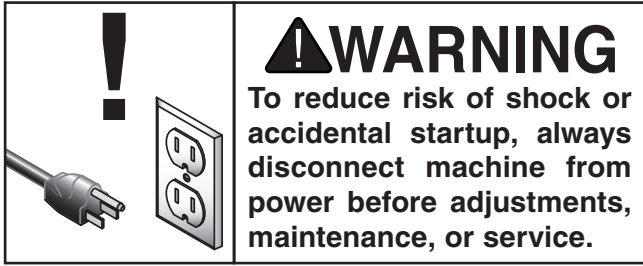

Figure 41. Recommended products for protecting unpainted cast iron/steel part on machinery.

order online at www.grizzly.com or call 1-800-523-4777



SECTION 6: MAINTENANCE



Schedule

For optimum performance from your machine, follow this maintenance schedule and refer to any specific instructions given in this section.

Daily

- Vacuum all dust on and around the machine.
- Wipe down the tables and all other unpainted cast iron with a metal protectant.
- Check/repair for worn or damaged wires.
- Check/replace damaged cutterhead or blades/inserts.
- Check/retighten loose mounting bolts.
- Check/resolve any other unsafe condition.

Monthly

- V-belt tension, damage, or wear (**Page 36**).
- Clean/vacuum dust buildup from inside stand and off of motor.

Cleaning & Protecting

Cleaning the Model G0490/G0490X is relatively easy. Vacuum excess wood chips and sawdust, and wipe off the remaining dust with a dry cloth. If any resin has built up, use a resin-dissolving cleaner to remove it.

Protect the unpainted cast iron surfaces on the table by wiping the table clean after every use—this ensures moisture from wood dust does not remain on bare metal surfaces.

Keep tables rust-free with regular applications of products like G96® Gun Treatment, SLIPIT®, or Boeshield® T-9 (see **Page 32**).

Lubrication

Since all bearings are sealed and permanently lubricated, simply leave them alone until they need to be replaced. DO NOT lubricate them.

Table ways and the fence assembly should not be lubricated. If the tables appear to be stuck, disassemble and clean any foreign materials from the ways, then re-assemble.



SECTION 7: SERVICE

Review the troubleshooting and procedures in this section if a problem develops with your machine. If you need replacement parts or additional help with a procedure, call our Technical Support. **Note:** *Please gather the serial number and manufacture date of your machine before calling.*

Troubleshooting

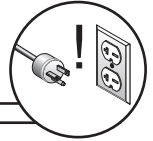

Symptom	Possible Cause	Possible Solution
Motor will not start.	<ol style="list-style-type: none"> 1. STOP button depressed. 2. Thermal overload protection tripped in magnetic switch. 3. Low voltage. 4. Open circuit in motor or loose connections. 	<ol style="list-style-type: none"> 1. Twist STOP button clockwise until it pops out. 2. Press "Reset" button on thermal overload relay, located inside magnetic switch. 3. Check power line for proper voltage. 4. Inspect all lead connections on motor for loose or open connections (Page 47).
Fuses or circuit breakers blow.	<ol style="list-style-type: none"> 1. Short circuit in line cord or plug. 2. Circuit breaker at fault. 	<ol style="list-style-type: none"> 1. Repair or replace cord or plug for damaged insulation and shorted wires. 2. Replace circuit breaker.
Motor overheats.	<ol style="list-style-type: none"> 1. Motor overloaded during operation. 2. Air circulation through the motor restricted. 	<ol style="list-style-type: none"> 1. Reduce load on motor; take lighter cuts. 2. Clean off motor to provide normal air circulation.
Motor stalls or shuts off during a cut.	<ol style="list-style-type: none"> 1. Motor overloaded during operation. 2. Thermal overload protection tripped in magnetic switch. 3. Short circuit on motor or in wiring. 4. Circuit breaker tripped. 	<ol style="list-style-type: none"> 1. Reduce load on motor; take lighter cuts. 2. Press the "Reset" button on thermal overload relay, located inside magnetic switch. 3. Repair or replace wiring connections on motor (Page 47). 4. Install correct circuit breaker; reduce # of machines running on that circuit (circuit overload).
Blade slows when cutting or makes a squealing noise, especially on start-up.	<ol style="list-style-type: none"> 1. V-belt loose. 2. V-belt worn out. 	<ol style="list-style-type: none"> 1. Retension V-belt (Page 36). 2. Replace V-belt (Page 36).
Loud repetitious noise coming from machine.	<ol style="list-style-type: none"> 1. Pulley set screws or keys are missing or loose. 2. Motor fan is hitting the cover. 3. V-belt is damaged. 	<ol style="list-style-type: none"> 1. Inspect keys and set screws. Replace or tighten if necessary. 2. Adjust fan cover mounting position, tighten fan, or shim fan cover. 3. Replace V-belt (Page 36).
Vibration when running or cutting.	<ol style="list-style-type: none"> 1. Loose or damaged blade. 2. Damaged V-belt. 3. Worn cutterhead bearings. 	<ol style="list-style-type: none"> 1. Tighten or replace blade. 2. Replace (Page 36). 3. Check/replace cutterhead bearings.
Tables are hard to adjust.	<ol style="list-style-type: none"> 1. Table lock is engaged or partially engaged. 2. Table stops blocking movement. 	<ol style="list-style-type: none"> 1. Completely loosen table lock. 2. Loosen/reset table stops (Pages 43 & 44).
Excessive snipe (gouge in the end of the board that is uneven with the rest of the cut).	<ol style="list-style-type: none"> 1. Outfeed table is set too low. 2. Operator pushing down on trailing end of the workpiece. 	<ol style="list-style-type: none"> 1. Align outfeed table with cutterhead knife at top dead center (Page 43). 2. Reduce/eliminate downward pressure on that end of workpiece.



Symptom	Possible Cause	Possible Solution
Workpiece stops in the middle of the cut.	1. Outfeed table is set too high.	1. Align outfeed table with cutterhead knife at top dead center (Page 43).
Chipping marks in workpiece.	1. Knots or conflicting grain direction in wood. 2. Nicked or chipped blades/inserts. 3. Feeding workpiece too fast. 4. Taking too deep of a cut.	1. Inspect workpiece for knots and grain (Page 26); only use clean stock. 2. Adjust one of the nicked knives sideways/rotate inserts; replace knives/inserts (Page 37). 3. Slow down the feed rate. 4. Take a smaller depth of cut. (Always reduce cutting depth when surface planing or working with hard woods.)
Fuzzy grain in workpiece.	1. Wood may have high moisture content or surface wetness. 2. Dull knives/inserts.	1. Check moisture content and allow to dry if moisture is too high. 2. Replace knives/rotate or replace inserts (Pages 37).
Long lines or ridges that run along the length of the board.	1. Nicked or chipped knives/inserts.	1. Adjust one of the nicked knives sideways/rotate inserts; replace knives/inserts (Pages 37).
Uneven cutter marks, wavy surface, or chatter marks across the face of the board.	1. Feeding workpiece too fast. 2. Knives not adjusted at even heights in the cutterhead (G0490 only).	1. Slow down the feed rate. 2. Adjust the knives so they are set up evenly in cutterhead (Page 37).
Board edge is concave or convex after jointing.	1. Board not held with even pressure on infeed and outfeed table during cut. 2. Board started too uneven. 3. Board has excessive bow or twist along its length. 4. Insufficient number of passes.	1. Hold board with even pressure as it moves over cutterhead. 2. Take partial cuts to remove the extreme high spots before doing a full pass. 3. Surface plane one face so there is a good surface to position against fence. 4. It may take 3 to 5 passes to achieve a perfect edge, depending on starting condition of board and depth of cut.



Servicing Poly V-Belt

To ensure optimum power transmission from the motor to the cutterhead, the poly V-belt must be in good condition (free from cracks, fraying and wear) and properly aligned and tensioned.

Tool Needed	Qty
Wrench or Socket 12mm.....	1
Wrench or Socket 13mm.....	1

Aligning Pulleys

1. DISCONNECT JOINTER FROM POWER!
2. Visually check alignment of cutterhead and motor pulleys, as illustrated in **Figure 42**.

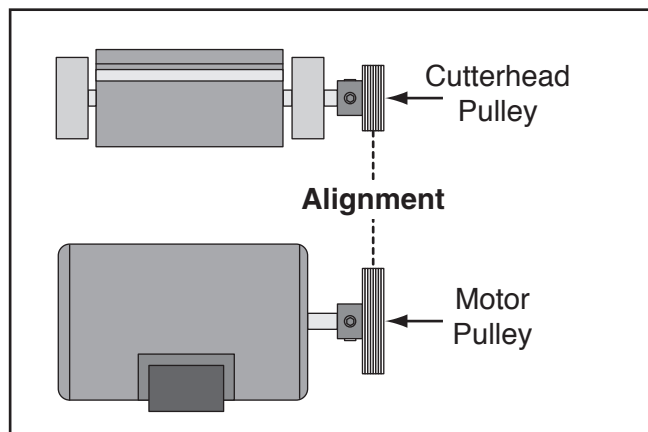

Figure 42. Pulleys aligned.

—If they are not aligned, loosen the four mounting carriage bolts shown in **Figure 43**, shift motor horizontally to align pulleys, then retighten carriage bolts.

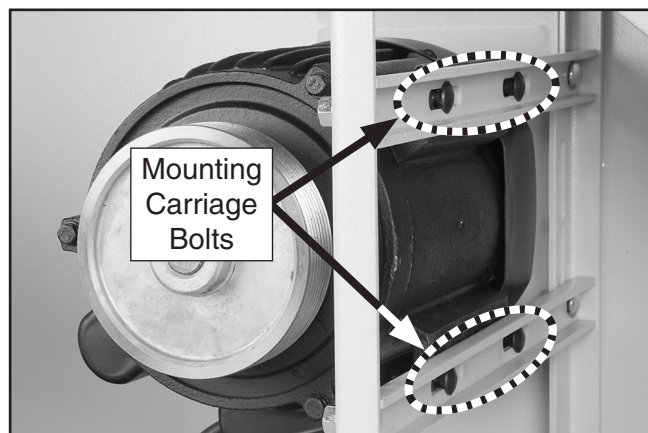

Figure 43. Motor adjustment controls.

Replacing/Tensioning V-Belt

1. DISCONNECT JOINTER FROM POWER!
2. Loosen carriage bolts securing motor mounting brackets (see **Figure 44**).

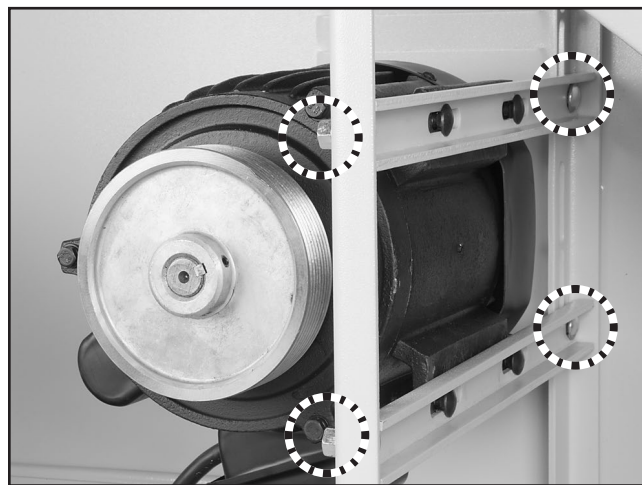

Figure 44. Motor mounting carriage bolts.

3. Have another person lift motor up as you replace V-belt. Make sure ribs of V-belt are seated in pulley grooves.
4. Allow motor to slide down to tension V-belt.

Note: When properly tensioned, there is approximately $\frac{1}{4}$ " deflection of belt as moderate pressure is applied midway between the pulleys, as illustrated in **Figure 45**. If necessary, apply downward pressure on motor to attain proper belt tension.

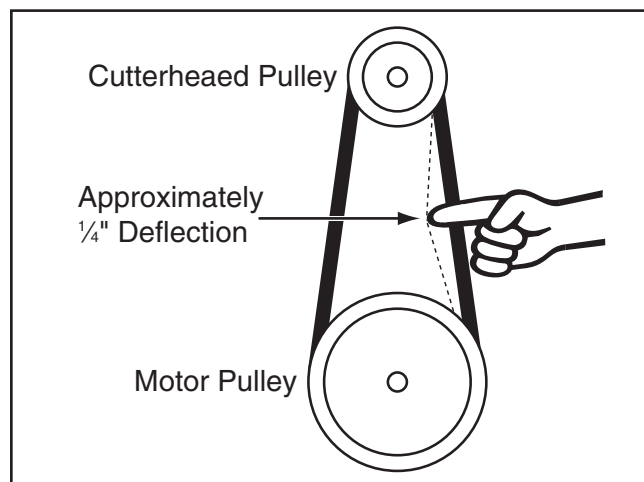

Figure 45. Correct belt deflection when properly tensioned.



Inspecting Knives (G0490)

Inspecting Knife Height

Use the knife-setting jig to verify that all cutterhead knives are all set to the correct height and protruding evenly from one side of the cutterhead to the other.

To inspect positioning of knives in cutterhead:

1. DISCONNECT JOINTER FROM POWER!
2. Remove cutterhead guard or block it open.
3. Lower infeed table to 1/2" scale mark.
4. Place knife jig on cutterhead, directly over a knife.
5. Closely examine how jig touches cutterhead and knife. The knife is set correctly when, on each side of cutterhead, both legs of jig sit firmly on cutterhead body and middle pad of jig just touches top edge of knife.

—If the jig does not sit as described, then that knife must be reset. (Repeat this inspection with the other knives before resetting.)



CAUTION

The cutterhead knives are very sharp and can easily cut your fingers or hands. Wear heavy leather gloves and take great care when handling cutterhead knives to avoid personal injury.

Setting Knives (G0490)

Setting the knives correctly is crucial to the proper operation of the jointer and it plays an important role in keeping the knives sharp. If one knife is higher than the others, it will do the majority of the work, and thus, become dull much faster.

The knife jig included with the jointer is designed to set the knives at the correct height.

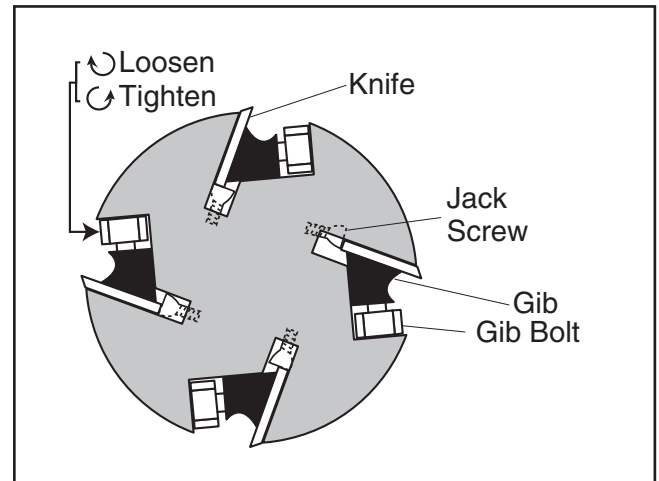

Figure 46. Profile of cutterhead with knives.

Tools Needed	Qty
Knife Setting Gauge	1
Hex Wrench 2.5mm.....	1
Wrench 10mm	1

To set cutterhead knives:

1. DISCONNECT JOINTER FROM POWER!
2. Remove cutterhead guard from table. Lower both tables as far as they go. This provides unrestricted access to cutterhead.
3. From backside of jointer, remove cabinet cover to expose V-belt.
4. Use V-belt to rotate cutterhead and position knives.



5. Loosen cutterhead gib bolts, starting in the middle, and alternating back and forth until all gib bolts are loose, but not falling out.
6. Position knife setting gauge over knife. Loosen gib bolts until knife is completely loose.
7. Access jack screws through holes in cutterhead. Using a hex wrench, rotate jack screws to raise or lower knife. When knife is set correctly, it will barely touch middle pad of gauge. Snug gib bolts just tight enough to hold knife in place. Repeat with remaining knives.
8. Rotate cutterhead to reveal the first knife you started with. Lightly snug all gib bolts, alternating from one side to the other, and working from the ends to the middle. Repeat with remaining knives.
9. Tighten each gib bolt in the same alternating manner as you did in previous step.
10. Set outfeed table even with the new knives at top-dead center (refer to **Setting Outfeed Table Height** on **Page 43** for detailed instructions).

Cutterhead Inserts (G0490X)

The spiral cutterhead is equipped with indexable carbide inserts. Each insert can be rotated to reveal any one of its four cutting edges. Therefore, if one cutting edge becomes dull or damaged, simply rotate it 90° to reveal a fresh cutting edge as shown below.

Each insert has a reference dot on one corner. As the insert is rotated, the reference dot location can be used as an indicator of which edges are used and which are new. Replace insert when the reference dot has been used and rotated back to its starting position.

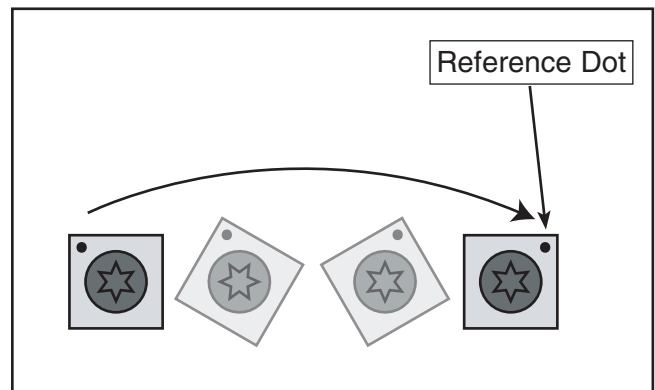

To rotate or replace spiral cutterhead insert:

1. DISCONNECT MACHINE FROM POWER!
2. Remove cutterhead guard from table, and lower infeed table as far as it will go, to provide access to cutterhead.
3. Remove cabinet bottom access panel to expose cutterhead pulley.
4. Rotate cutterhead pulley to provide access to insert(s) to be rotated/replaced.
5. Put on heavy leather gloves to protect fingers and hands.
6. Remove any sawdust or debris from head of insert, Torx screw, and surrounding area (see **Figure**).
7. Remove Torx screw and insert, then clean all dust and debris from both parts and pocket they were removed from.

Note: *Proper cleaning of insert(s), Torx screw, and cutterhead pocket is critical to achieving a smooth finish. Dirt or dust trapped between insert and cutterhead will raise insert, and make marks on your workpiece when jointing.*

Tip: *Use low-pressure compressed air or vacuum nozzle to clean cutterhead pocket.*

8. Re-install insert so that a fresh cutting edge faces outward, making sure it is properly seated in cutterhead pocket.

—If all four insert cutting edges have been used, replace insert with a new one. Always position reference dot in same position when installing a new insert to aid in rotational sequencing.

9. Lubricate Torx screw threads with a small amount of light machine oil, wipe excess off, and torque screw to 48–50 inch/pounds.

Note: *If too much oil is applied to the threads, excess will attempt to squeeze out of threaded hole as you install insert and force it to raise slightly, making it out of alignment.*

Checking/Adjusting Table Parallelism

If the tables are not parallel with the cutterhead or each other, then poor cutting results and kickback can occur.

Tools Needed

	Qty
Straightedge	1
Wrench 17mm.....	1
Hex Wrench 8mm.....	1
Hex Wrench 4mm.....	1
Hex Wrench 3mm.....	1

Checking Outfeed Table

1. DISCONNECT JOINTER FROM POWER!
2. Remove cutterhead guard, fence, and rear stand panel.
3. Loosen outfeed table lock located at front of the machine, and loosen jam nuts and positive stop bolts located at the back of machine just behind outfeed table (see **Figure 47**).

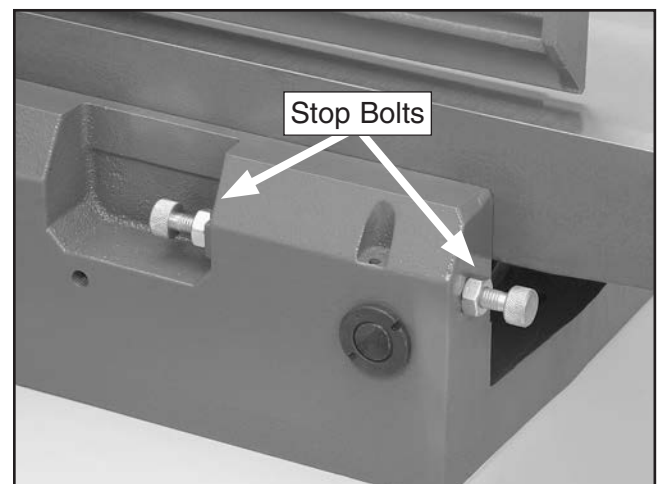

Figure 47. Outfeed table positive stop bolts.



4. Rotate motor pulley so that you can access cutterhead body with straightedge between the knives/inserts, as shown in **Figure 48**.

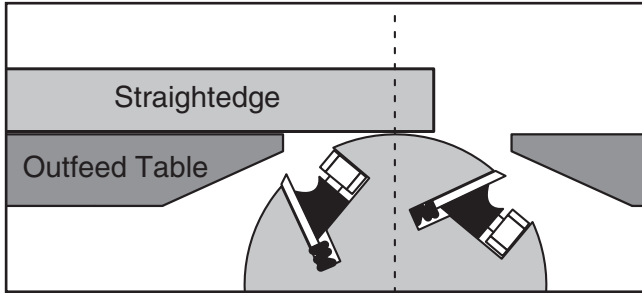

Figure 48. Adjusting outfeed table even with cutterhead body (knife-style cutterhead shown).

5. Place straightedge on outfeed table so it hangs over cutterhead, then lower outfeed table until straightedge just touches cutterhead body.
6. Place straightedge in positions shown in **Figure 49**. In each position, straightedge should touch cutterhead and sit flat on outfeed table.

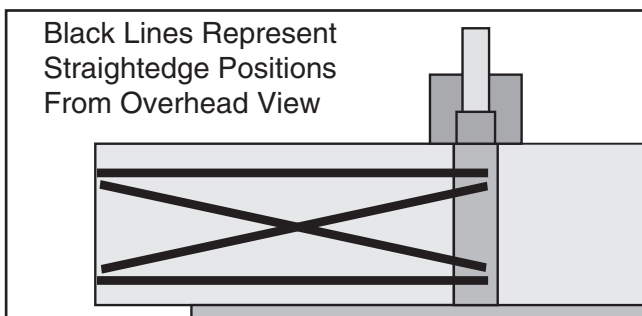

Figure 49. Straightedge positions for verifying if outfeed table is parallel with cutterhead.

—If straightedge touches cutterhead body and sits flat across outfeed table in each position, then outfeed table is already parallel with cutterhead. Follow the **Checking Infeed Table** instructions on this page.

—If straightedge does not touch cutterhead and sits flat on outfeed table in any of the positions, then outfeed table is not parallel with cutterhead. Perform **Adjusting Table Parallelism** procedure on next page, then perform **Checking Infeed Table** instructions on this page.

Checking Infeed Table

1. Follow all steps for checking outfeed table parallelism to first make sure that outfeed table is parallel with cutterhead.
2. Correctly adjust the outfeed table height (refer to **Setting Outfeed Table Height** on **Page 43** for detailed instructions).
3. Rotate cutterhead so knives/inserts will not interfere, then place straightedge infeed and outfeed tables and adjust infeed table even with outfeed table, as shown in **Figure 50**.

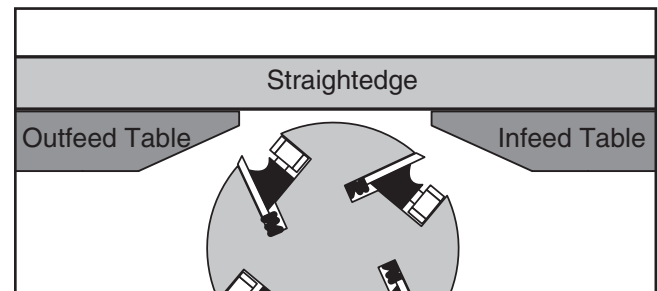

Figure 50. Infeed and outfeed tables set evenly (knife-style cutterhead shown).

4. Place straightedge in the positions shown in **Figure 51**. In each position, straightedge should sit flat against both outfeed table and infeed table.

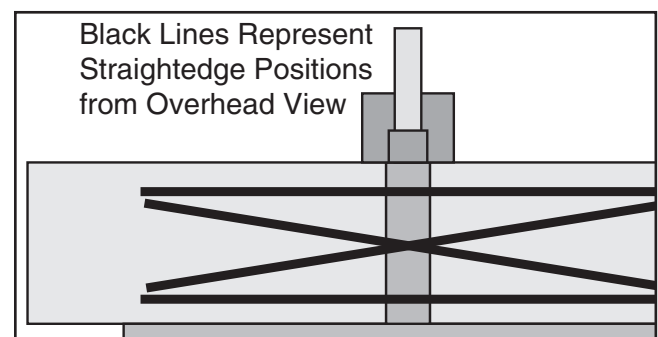

Figure 51. Straightedge positions for checking infeed/outfeed table parallelism.

—If straightedge sits flat against both infeed and outfeed tables, then tables are parallel. Replace cutterhead guard, fence, and rear stand panel.

—If straightedge does not sit flat against both infeed and outfeed tables in any of the positions, then follow **Adjusting Table Parallelism** instructions on the next page.



Adjusting Table Parallelism

For safe and proper cutting results, the tables must be parallel to the cutterhead. Adjusting them to be parallel is a task of precision and patience, and may take up to one hour to complete. Luckily, this is considered a permanent adjustment and should not need to be repeated for the life of the machine.

Due to the complex nature of this task, we recommend that you double check the current table positions to make sure that they really need to be adjusted before starting.

Each table has four eccentric bushings on the base underneath the table that allow the table to be adjusted parallel. These eccentric bushings are locked in place by piggybacked set screws (one on top of the other) and adjust when these set screws are rotated.

The correct order for adjusting the table parallelism is to first adjust the outfeed table parallel with the cutterhead, then adjust the infeed table parallel with the outfeed table.

When setting the outfeed table, all measurements **MUST** be made from the cutterhead body—not the knives/inserts or the results may be skewed.

Important: *The steps below are intended to be performed directly after the steps involved in checking the outfeed table parallelism. Do not continue until you have performed those steps.*

To adjust table parallelism:

1. Place straightedge on outfeed table so it hangs over cutterhead, and lower outfeed table until straightedge just touches cutterhead *body*, as shown in **Figure 52**.

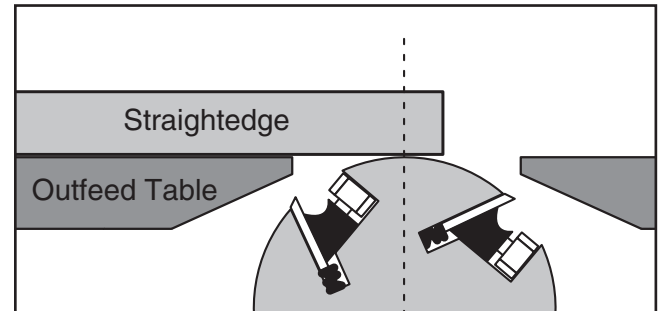

Figure 52. Adjusting outfeed table even with cutterhead body (knife-style cutterhead shown).

2. Remove top set screw from each of the four eccentric bushings under outfeed table, and loosen set screws underneath those removed set screws (see **Figure 53**).

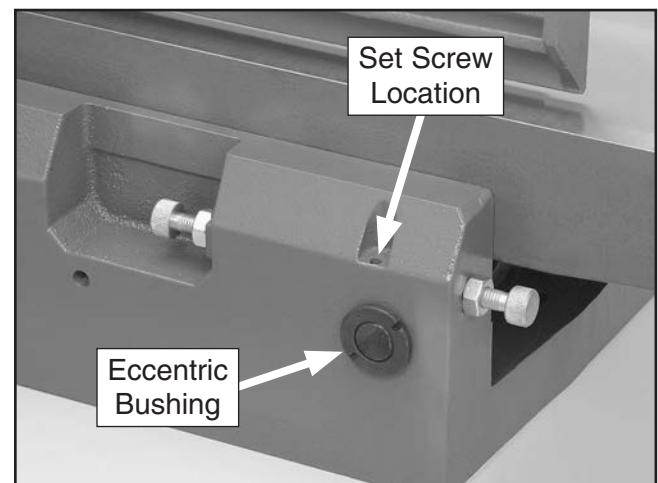

Figure 53. Eccentric bushing and set screw location.



- Place straightedge in one of the positions shown in **Figure 54**, and adjust eccentric bushings so straightedge touches cutterhead body while lying flat across outfeed table (a pin-type spanner wrench or small hammer and punch may be necessary to turn eccentric bushings).

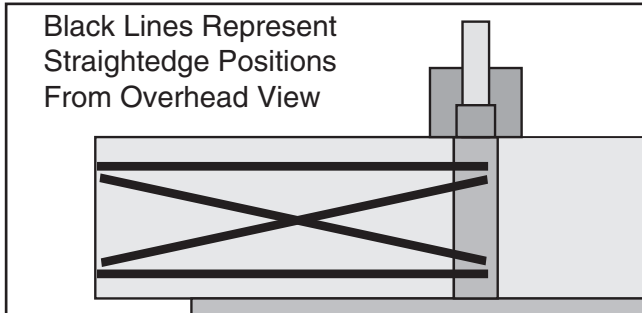

Figure 54. Straightedge positions for verifying if outfeed table is parallel with cutterhead.

- Repeat **Step 3** with each of remaining straight-edge positions as many times as necessary until outfeed table is parallel with cutterhead.
- Tighten/replace set screws in eccentric bushings on outfeed table.
- Remove set screw from each of the four eccentric bushings under infeed table, and loosen set screws underneath those removed set screws.
- Place straightedge halfway across infeed and outfeed tables, and adjust infeed table even with outfeed table, as shown in **Figure 55**.

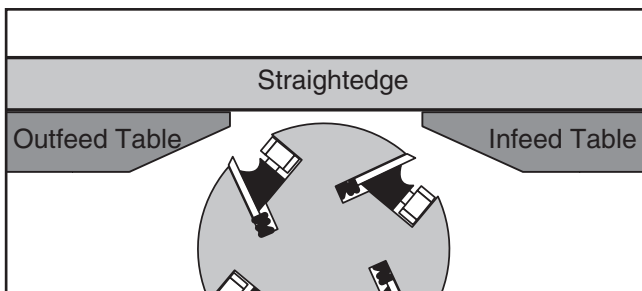

Figure 55. Infeed and outfeed tables set evenly (knife-style cutterhead shown).

- Place straightedge in one of the positions shown in **Figure 56**, and adjust eccentric bushings under infeed table so straightedge lies flat against both tables.

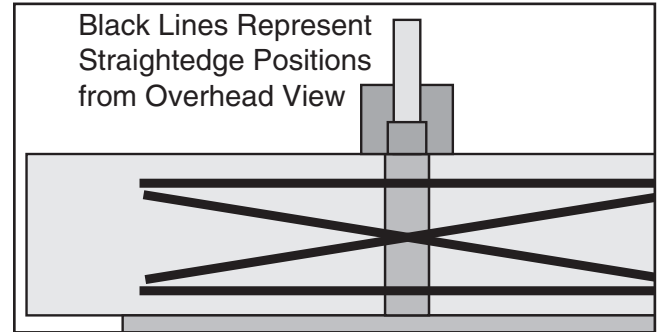

Figure 56. Straightedge positions for checking infeed/outfeed table parallelism.

- Repeat **Step 8** with each remaining straight-edge positions as many times as necessary until infeed table is parallel with outfeed table.
- Tighten/replace set screws in eccentric bushings on infeed table.
- Perform **Setting Outfeed Table Height** on next page.



Setting Outfeed Table Height

The outfeed table height must be even with the top of the cutterhead knives. If the outfeed table is set too low, there will be snipe. If the outfeed table is set too high, the workpiece will hit the edge of the outfeed table during operation, increasing the chance of kickback.

Tools Needed	Qty
Straightedge	1
Wrench 17mm.....	1
Hex Wrench 8mm.....	1
Hex Wrench 4mm.....	1
Hex Wrench 3mm.....	1
Feeler Gauge(s) 0.062"	1

To set outfeed table height:

1. DISCONNECT JOINTER FROM POWER!
2. Remove cutterhead guard, fence, and rear stand panel.
3. **Knife-Style Cutterhead Only:** Correctly set knife heights (refer to **Setting Knives (G0490)** on **Page 37** for detailed instructions).
4. Loosen outfeed table lock located at front of machine, and loosen jam nuts and positive stop bolts located at back of machine just behind outfeed table (see **Figure 57**).

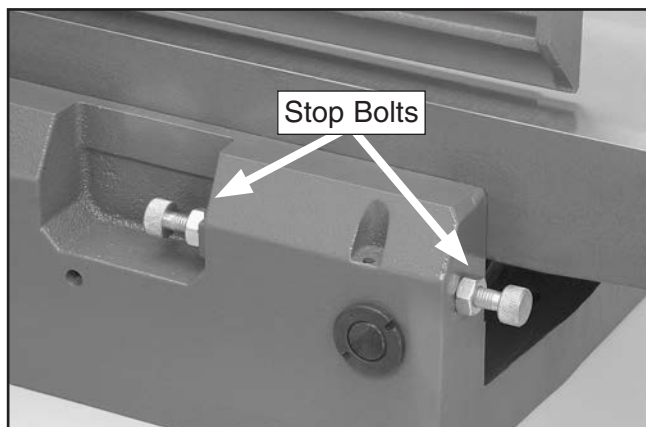

Figure 57. Outfeed table positive stop bolts.

5. Place straightedge on outfeed table so it extends over cutterhead.

6. Use motor pulley to rotate cutterhead until one of the knives or inserts is at top dead center (its highest point during rotation), as illustrated in **Figures 58–59**.

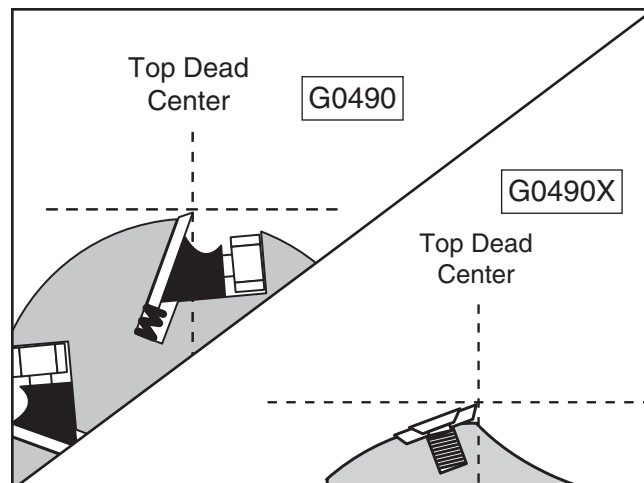

Figure 58. Knife or insert at top dead center.

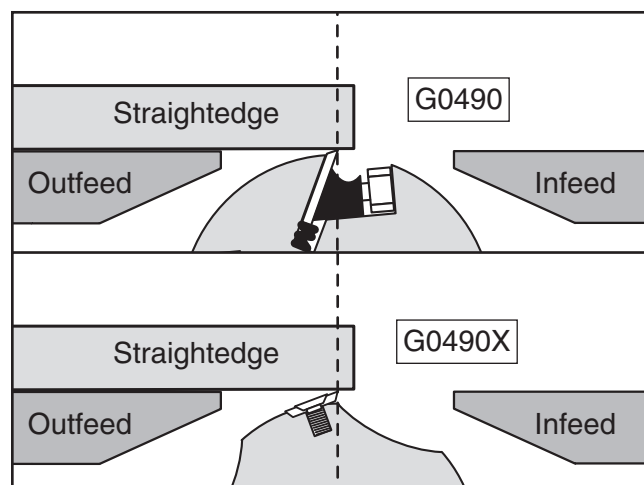

Figure 59. Using straightedge to check outfeed table height.

7. Use outfeed table adjustment lever to set outfeed table so that knife or insert barely touches straightedge, as illustrated in **Figure 59**.
8. Tighten outfeed table lock located at front of machine, and tighten positive stop bolts and jam nuts located at back of machine (see **Figure 57**) so that outfeed table will not move during operation.
9. Reinstall cutterhead guard, fence, and rear stand panel.



Adjusting Infeed Table Stop Bolts

The infeed table on your jointer has positive stop bolts that, when properly set up, allow you to quickly adjust the infeed table to perform heavy or light cuts.

Each positive stop bolt controls top or bottom range of table movement (see **Figure 60**). Jam nuts lock positive stop bolts in position so they will not move during operation.

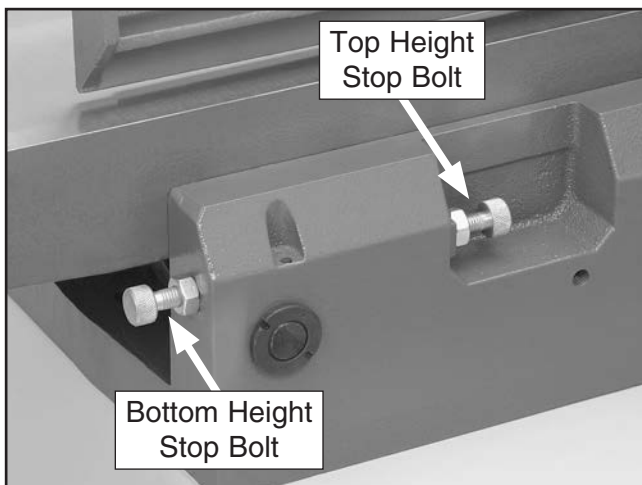

Figure 60. Positive stop bolts for infeed table.

Calibrating Depth Scale

The depth scale can be calibrated or "zeroed" to make sure the cutting depth shown on the scale matches the actual cutting depth (per pass).

Tools Needed	Qty
Straightedge	1
Phillips Screwdriver	1

To calibrate depth scale:

1. DISCONNECT JOINTER FROM POWER!
2. Set outfeed table height as described in **Setting Outfeed Table Height on Page 43**.
3. Place a straightedge across infeed and outfeed tables.
4. Adjust infeed table until it is level with outfeed table, as shown in **Figure 61**.

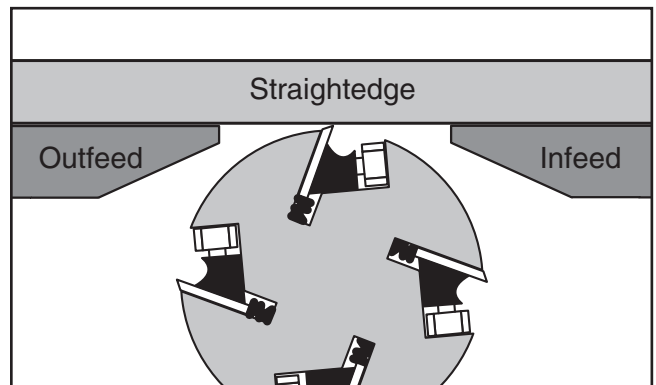

Figure 61. Infeed table even with outfeed table.

5. Using a screwdriver, precisely adjust scale pointer to "0" (see **Figure 62**).

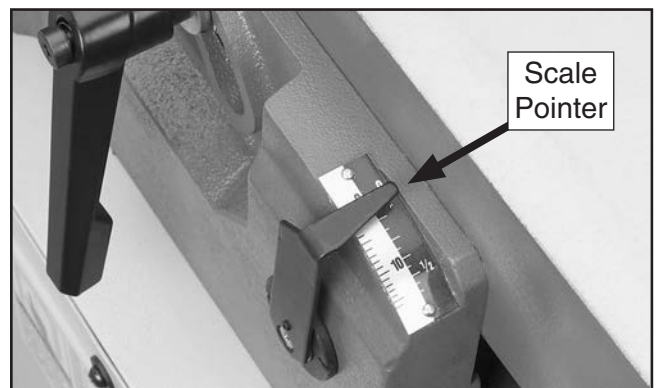

Figure 62. Depth scale pointer adjusted to "0".



Setting Fence Stops

The fence stops simplify the task of adjusting the fence to 45° inward, 90°, and 45° outward (135°).

Tools Needed	Qty
45° Square	1
90° Square	1
Sliding Bevel.....	1
Wrench 10mm	1
Hex Wrench 4mm.....	1

Setting 45° Inward Fence Stop

1. DISCONNECT JOINTER FROM POWER!
2. Tilt fence approximately 45° inward onto stop bolt, as shown in **Figure 63**, then place 45° square against fence and table.

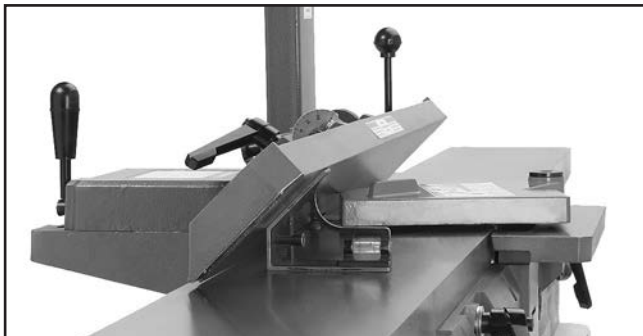

Figure 63. Fence adjusted 45° inward.

3. Loosen jam nut on 45° inward stop bolt shown in **Figure 64**.

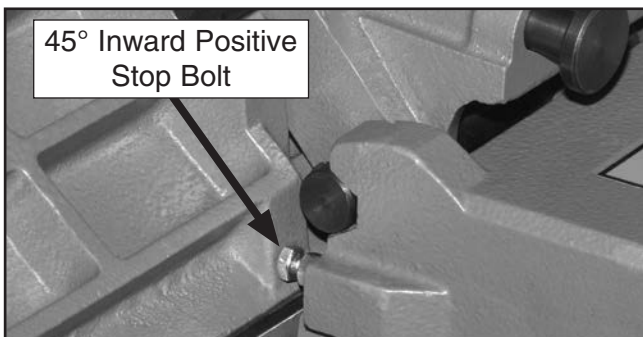

Figure 64. 45° inward positive stop bolt.

4. Adjust stop bolt until fence is exactly 45° inward while resting on bolt (verify angle with a 45° square), then retighten jam nut loosened in **Step 3**.

Setting 90° Fence Stop

1. DISCONNECT JOINTER FROM POWER!
2. Loosen set screw in plunger lock collar shown in **Figure 65**, and loosen fence tilt lock.

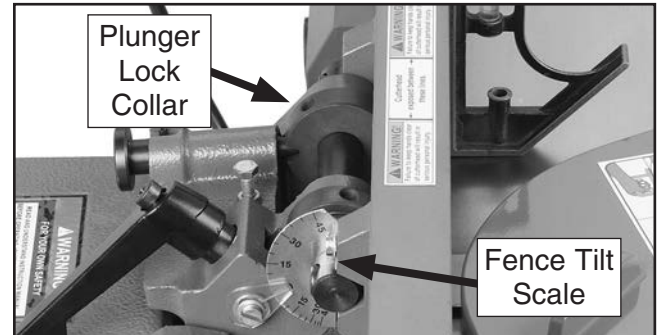

Figure 65. Adjusting fence to 90°.

3. Using a 90° square, adjust fence to 90° position, as shown in **Figure 65**, then tighten set screw in plunger lock collar.
4. Adjust indicator (if necessary) to 0° to calibrate fence tilt scale.

Setting 45° Outward Fence Stop

1. DISCONNECT JOINTER FROM POWER!
2. Loosen fence tilt lock, and position fence against 45° outward stop bolt.
3. Loosen jam nut on 45° outward fence stop bolt shown in **Figure 66**.



Figure 66. Adjusting fence 45° outward.

4. Adjust 45° outward stop bolt until fence is exactly 45° outward while resting on bolt (check the angle with a sliding bevel set to 135°), then retighten jam nut loosened in **Step 3**.



SECTION 8: WIRING

These pages are current at the time of printing. However, in the spirit of improvement, we may make changes to the electrical systems of future machines. Study this section carefully. If there are differences between your machine and what is shown in this section, call Technical Support at (570) 546-9663 for assistance BEFORE making any changes to the wiring on your machine.

WARNING

Wiring Safety Instructions

SHOCK HAZARD. Working on wiring that is connected to a power source is extremely dangerous. Touching electrified parts will result in personal injury including but not limited to severe burns, electrocution, or death. Disconnect the power from the machine before servicing electrical components!

MODIFICATIONS. Modifying the wiring beyond what is shown in the diagram may lead to unpredictable results, including serious injury or fire. This includes the installation of unapproved after-market parts.

WIRE CONNECTIONS. All connections must be tight to prevent wires from loosening during machine operation. Double-check all wires disconnected or connected during any wiring task to ensure tight connections.

CIRCUIT REQUIREMENTS. You MUST follow the requirements at the beginning of this manual when connecting your machine to a power source.

WIRE/COMPONENT DAMAGE. Damaged wires or components increase the risk of serious personal injury, fire, or machine damage. If you notice that any wires or components are damaged while performing a wiring task, replace those wires or components.

MOTOR WIRING. The motor wiring shown in these diagrams is current at the time of printing but may not match your machine. If you find this to be the case, use the wiring diagram inside the motor junction box.















CAPACITORS/INVERTERS. Some capacitors and power inverters store an electrical charge for up to 10 minutes after being disconnected from the power source. To reduce the risk of being shocked, wait at least this long before working on capacitors.

EXPERIENCING DIFFICULTIES. If you are experiencing difficulties understanding the information included in this section, contact our Technical Support at (570) 546-9663.

NOTICE

The photos and diagrams included in this section are best viewed in color. You can view these pages in color at www.grizzly.com.

COLOR KEY

BLACK 	BLUE 	YELLOW 	LIGHT BLUE 
WHITE 	BROWN 	YELLOW GREEN 	BLUE WHITE 
GREEN 	GRAY 	PURPLE 	TURQUOISE 
RED 	ORANGE 	PINK 	



G0490/G0490X Wiring

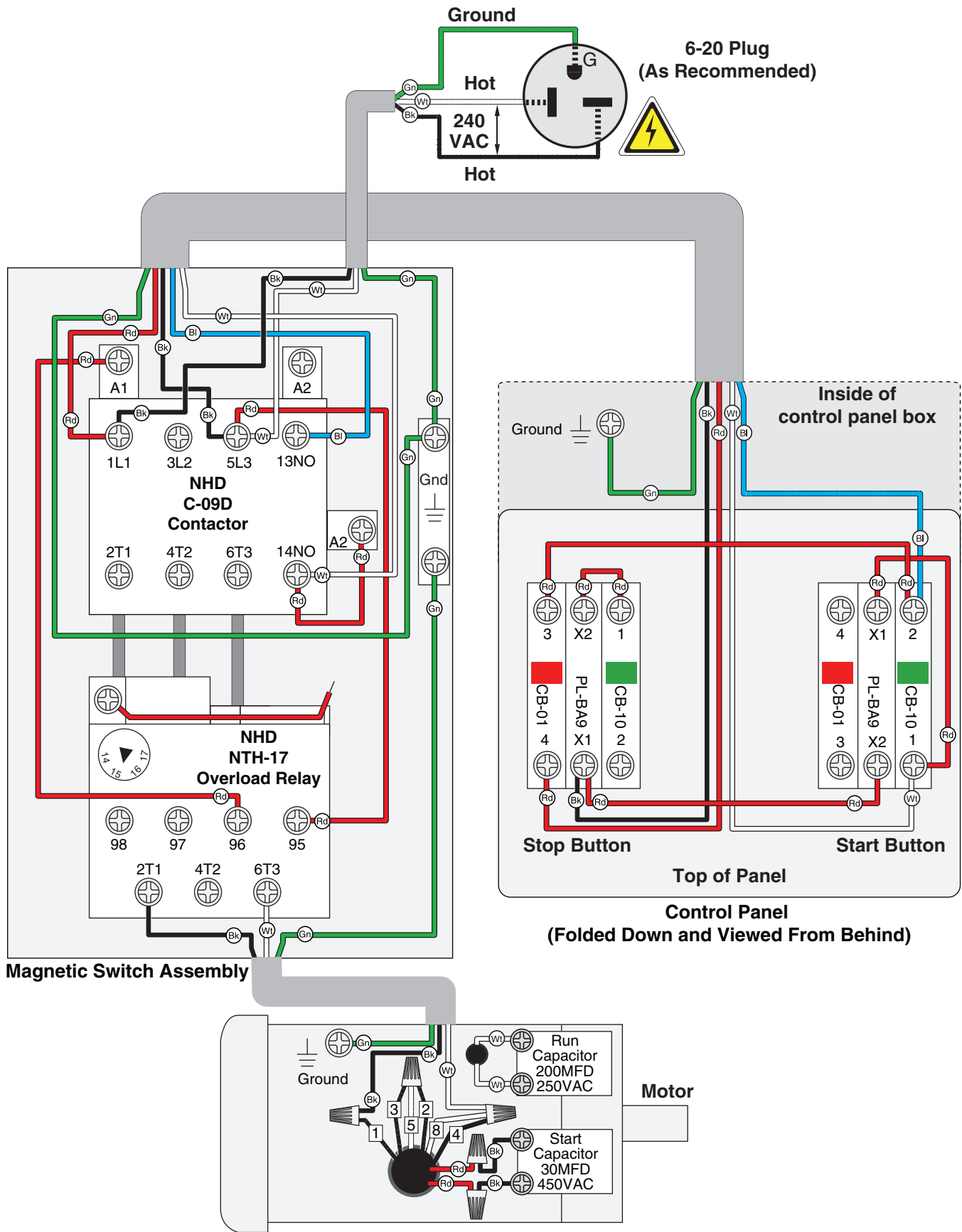

G0490/G0490X Wiring Photos



Figure 67. Magnetic switch assembly.

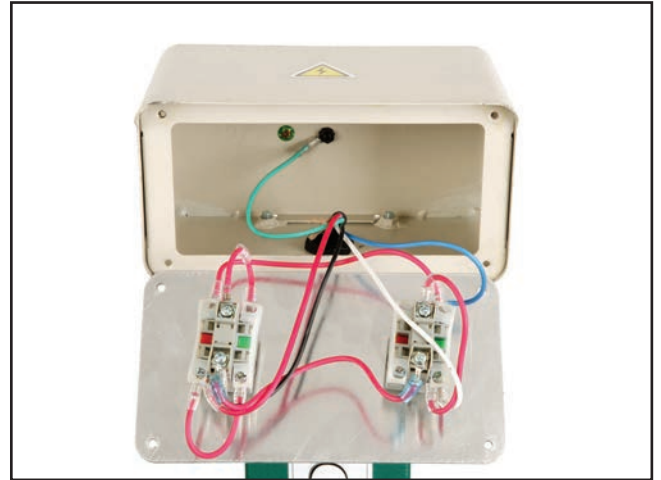

Figure 69. Control panel.

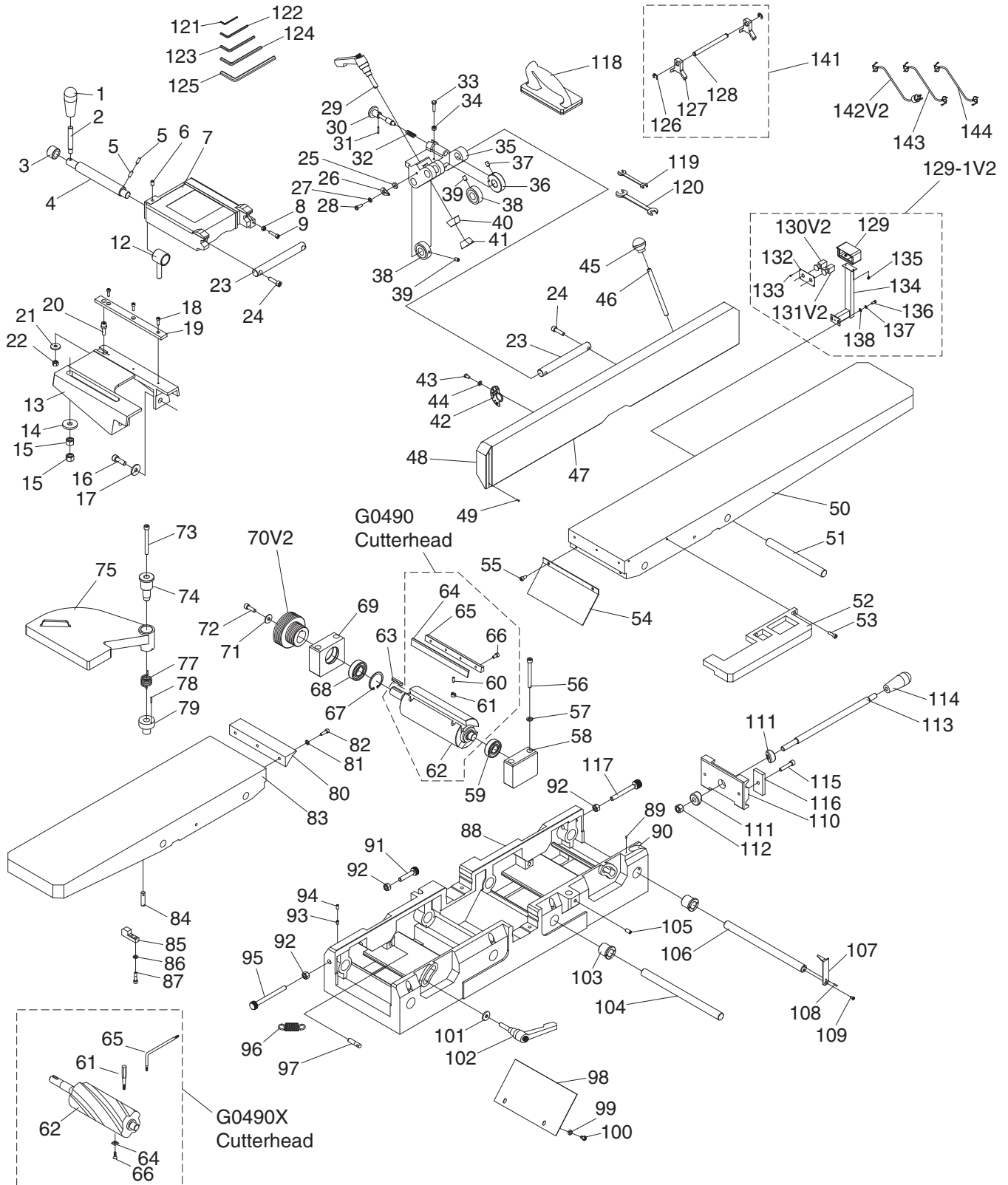

Figure 68. Motor and capacitors.



SECTION 9: PARTS

Jointer Breakdown



Jointer Parts List

REF	PART #	DESCRIPTION
1	P0490001	KNOB M12-1.75, OBLONG
2	P0490002	STUD-UDE M12-1.75 X 20, M10-1.5 X 15, 80L
3	P0490003	BUSHING
4	P0490004	ECCENTRIC SHAFT
5	P0490005	SET SCREW M6-1 X 16
6	P0490006	SET SCREW M8-1.25 X 12
7	P0490007	FENCE CARRIAGE
8	P0490008	HEX NUT M6-1
9	P0490009	HEX BOLT M6-1 X 25
12	P0490012	COLLAR
13	P0490013	FENCE SUPPORT
14	P0490014	FLAT WASHER 12MM
15	P0490015	HEX NUT M12-1.75
16	P0490016	CAP SCREW M10-1.5 X 30
17	P0490017	FLAT WASHER 10MM
18	P0490018	CAP SCREW M5-.8 X 16
19	P0490019	FENCE GIB
20	P0490020	ECCENTRIC SHAFT
21	P0490021	FLAT WASHER 8MM
22	P0490022	HEX NUT M8-1.25
23	P0490023	SHAFT W/2 HOLES
24	P0490024	CAP SCREW M8-1.25 X 30
25	P0490025	FLAT WASHER 6MM
26	P0490026	POINTER
27	P0490027	FLAT WASHER 6MM
28	P0490028	PHLP HD SCR M6-1 X 16
29	P0490029	ADJUSTABLE HANDLE M10-1.5 X 25
30	P0490030	INDEX PIN ASSEMBLY
31	P0490031	ROLL PIN 3 X 20
32	P0490032	COMPRESSION SPRING
33	P0490033	HEX BOLT M6-1 X 25
34	P0490034	HEX NUT M6-1
35	P0490035	SWIVEL
36	P0490036	LOCK COLLAR
37	P0490037	HEX BOLT M8-1.25 X 12
38	P0490038	LOCK COLLAR
39	P0490039	HEX BOLT M8-1.25 X 12
40	P0490040	CLAMP
41	P0490041	THREADED CLAMP
42	P0490042	TILT SCALE
43	P0490043	PHLP HD SCR M6-1 X 10
44	P0490044	FLAT WASHER 6MM
45	P0490045	KNOB M10-1.5, ROUND
46	P0490046	STUD-DE M10-1.5 X 130, 10
47	P0490047	FENCE
48	P0490048	SCALE
49	P0490049	RIVET 2 X 4MM NAMEPLATE, STEEL
50	P0490050	INFEED TABLE
51	P0490051	TABLE SHAFT 202MM
52	P0490052	EXTENSION TABLE
53	P0490053	CAP SCREW M6-1 X 20
54	P0490054	CHIP DEFLECTOR
55	P0490055	CAP SCREW M6-1 X 12

REF	PART #	DESCRIPTION
56	P0490056	CAP SCREW M8-1.25 X 80
57	P0490057	LOCK WASHER 8MM
58	P0490058	FRONT BEARING PILLOW BLOCK
59	P0490059	BALL BEARING 6004-2RS
63	P0490063	KEY 6 X 6 X 35
67	P0490067	INT RETAINING RING 47MM
68	P0490068	BALL BEARING 6005-2RS
69	P0490069	REAR BEARING PILLOW BLOCK
70V2	P0490070V2	CUTTERHEAD PULLEY ALUM V2.03.09
71	P0490071	CUTTERHEAD PULLEY WASHER
72	P0490072	CAP SCREW M8-1.25 X 25
73	P0490073	CAP SCREW M8-1.25 X 80
74	P0490074	GUARD CLAMP
75	P0490075	CUTTERHEAD GUARD
77	P0490077	TORSION SPRING
78	P0490078	ROLL PIN 3 X 16
79	P0490079	SPRING RETAINER
80	P0490080	OUTFEED TABLE LIP
81	P0490081	FLAT WASHER 6MM
82	P0490082	CAP SCREW M6-1 X 20
83	P0490083	OUTFEED TABLE
84	P0490084	SLOTTED PIN W/HOLE
85	P0490085	BUMPER
86	P0490086	LOCK WASHER 6MM
87	P0490087	CAP SCREW M6-1 X 25
88	P0490088	TABLE BASE
89	P0490089	RIVET 2 X 4MM NAMEPLATE, STEEL
90	P0490090	HEIGHT SCALE
91	P0490091	ADJUSTING SCREW M10-1.5 X 50
92	P0490092	HEX NUT M10-1.5
93	P0490093	SET SCREW M6-1 X 10
94	P0490094	SET SCREW M6-1 X 10 CONE-PT
95	P0490095	ADJUSTING SCREW M10-1.5 X 110
96	P0490096	EXTENSION SPRING
97	P0490097	SLOTTED PIN W/HOLE
98	P0490098	CHIP BREAKER
99	P0490099	FLAT WASHER 6MM
100	P0490100	HEX BOLT M6-1 X 12
101	P0490101	FLAT WASHER 8MM
102	P0490102	ADJUSTABLE HANDLE M8-1.25 X 30
103	P0490103	ECCENTRIC BUSHING
104	P0490104	TABLE SHAFT 281MM
105	P0490105	SET SCREW M8-1.25 X 16
106	P0490106	TABLE SHAFT 281MM
107	P0490107	POINTER
108	P0490108	ROLL PIN 3 X 10
109	P0490109	FLAT HD SCR M4-.7 X 10
110	P0490110	PIVOT BRACKET
111	P0490111	ADJUSTING BLOCK
112	P0490112	HEX NUT M12-1.75
113	P0490113	LEVER
114	P0490114	KNOB M12-1.75, OBLONG
115	P0490115	CAP SCREW M8-1.25 X 40



Jointer Parts List

REF	PART #	DESCRIPTION
116	P0490116	CLAMP PLATE
117	P0490117	MEDIUM ADJUSTING SCREW
118	P0490118	PUSH BLOCK
119	P0490119	WRENCH 8 X 10MM OPEN-ENDS
120	P0490120	WRENCH 12 X 14MM OPEN-ENDS
121	P0490121	HEX WRENCH 2.5MM
122	P0490122	HEX WRENCH 4MM
123	P0490123	HEX WRENCH 5MM
124	P0490124	HEX WRENCH 6MM
125	P0490125	HEX WRENCH 8MM
126	P0490126	EXT RETAINING RING 8MM
127	P0490127	KNIFE JIG FOOT 1-PC
128	P0490128	KNIFE JIG ROD
129	P0490129	CONTROL PANEL BOX

REF	PART #	DESCRIPTION
129-1V2	P0490129-1V2	CONTROL PANEL PEDESTAL ASSY V2.01.11
130V2	P0490130V2	E-STOP BUTTON NHD NLB22-R 22MM V2.01.11
131V2	P0490131V2	START BUTTON NHD NLB22-E 22MM V2.01.11
132	P0490132	CONTROL PANEL
133	P0490133	TAP SCREW M4 X 8
134	P0490134	CONTROL PEDESTAL
135	P0490135	FLANGE SCREW M6-1 X 12
136	P0490136	CAP SCREW M10-1.5 X 25
137	P0490137	LOCK WASHER 10MM
138	P0490138	FLAT WASHER 10MM
141	P0490141	KNIFE SETTING JIG ASSEMBLY
142V2	P0490142V2	POWER CORD 12G 3W 72" 6-20P V2.08.12
143	P0490143	MOTOR CORD
144	P0490144	CONTROL PANEL CORD

G0490 Cutterhead Parts List

REF	PART #	DESCRIPTION
60	P0490060	SET SCREW M5-.8 X 16
61	P0490061	KNIFE LIFTER
62	P0490062	CUTTERHEAD 8" 4-KNIFE
64	P0490064	KNIVES 8" X 3/4" X 1/8" 4-PC SET
65	P0490065	KNIFE GIB
66	P0490066	KNIFE GIB SCREW

G0490X Cutterhead Parts List

REF	PART #	DESCRIPTION
61	P0490X061	DRIVER BIT TORX T20
62	P0490X062	SPIRAL CUTTERHEAD 8"
64	P0490X064	INDEXABLE INSERT 14 X 14 X 2 10-PK
65	P0490X065	L-WRENCH TORX T20
66	P0490X066	FLAT HD TORX T20 M6-1 X 15



Stand Breakdown

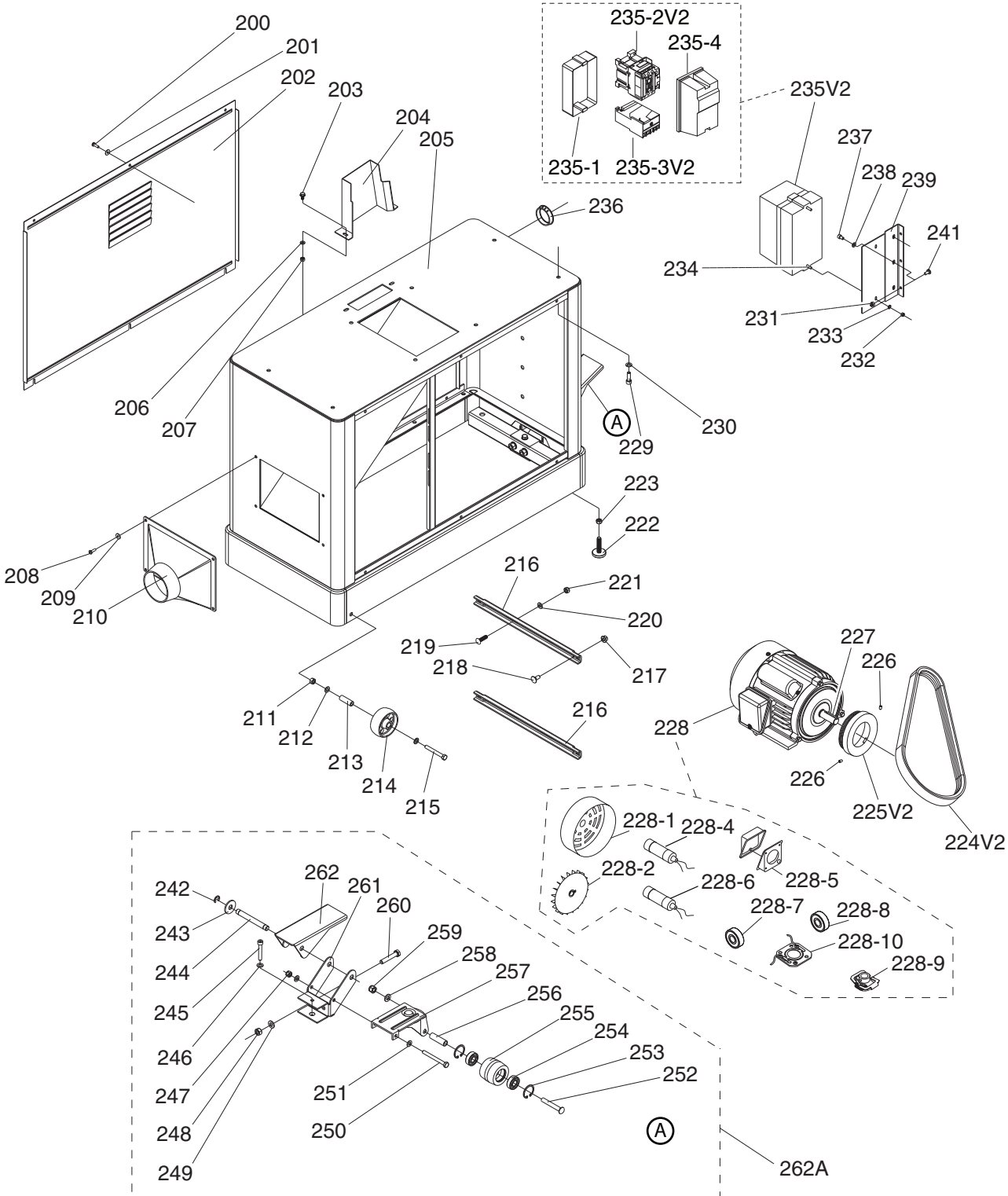

Stand Parts List

REF	PART #	DESCRIPTION
200	P0490200	PHLP HD SCR M5-.8 X 16
201	P0490201	FLAT WASHER 5MM
202	P0490202	REAR PANEL
203	P0490203	FLANGE SCREW M6-1 X 12
204	P0490204	BELT GUARD
205	P0490205	STAND
206	P0490206	FLAT WASHER 6MM
207	P0490207	HEX NUT M6-1
208	P0490208	PHLP HD SCR M5-.8 X 16
209	P0490209	FLAT WASHER 5MM
210	P0490210	DUST CHUTE
211	P0490211	HEX NUT M8-1.25
212	P0490212	FLAT WASHER 8MM
213	P0490213	SLEEVE
214	P0490214	UNIVERSAL WHEEL 78MM DIA
215	P0490215	HEX BOLT M8-1.25 X 65
216	P0490216	MOTOR BRACKET
217	P0490217	FLANGE NUT 5/16-18
218	P0490218	CARRIAGE BOLT 5/16-18 X 3/4
219	P0490219	CARRIAGE BOLT 5/16-18 X 1-1/4
220	P0490220	FLAT WASHER 5/16
221	P0490221	HEX NUT 5/16-18
222	P0490222	ADJUSTABLE FOOT 3/8-16 X 1-3/4
223	P0490223	HEX NUT 3/8-16
224V2	P0490224V2	POLY V-BELT 8PK-1172 V2.03.09
225V2	P0490225V2	ALUMINIUM MOTOR PULLEY V2.03.09
226	P0490226	SET SCREW M6-1 X 6
227	P0490227	KEY 5 X 5 X 30
228	P0490228	MOTOR 3HP 240V 1-PH
228-1	P0490228-1	MOTOR FAN COVER
228-2	P0490228-2	MOTOR FAN
228-4	P0490228-4	S CAPACITOR 200M 250V 1-3/4 X 3-1/4
228-5	P0490228-5	JUNCTION BOX
228-6	P0490228-6	R CAPACITOR 30M 450V
228-7	P0490228-7	BALL BEARING 6204ZZ
228-8	P0490228-8	BALL BEARING 6203ZZ
228-9	P0490228-9	CENT SWITCH 5/8-3450
228-10	P0490228-10	CONTACT PLATE

REF	PART #	DESCRIPTION
229	P0490229	CAP SCREW M8-1.25 X 25
230	P0490230	LOCK WASHER 8MM
231	P0490231	HEX NUT M6-1
232	P0490232	HEX NUT M5-.8
233	P0490233	FLAT WASHER 5MM
234	P0490234	PHLP HD SCR M5-.8 X 20
235V2	P0490235V2	MAG SWITCH NHD 3HP 230V V2.01.11
235-1	P0490235-1	REAR MAG SWITCH COVER
235-2V2	P0490235-2V2	CONTACTOR NHD C-09D 230V V2.07.12
235-3V2	P0490235-3V2	OL RELAY NHD NTH-17 14-17A V2.07.12
235-4	P0490235-4	FRONT MAG SWITCH COVER
236	P0490236	CORD GROMMET
237	P0490237	CAP SCREW M6-1 X 10
238	P0490238	FLAT WASHER 6MM
239	P0490239	SWITCH MOUNTING PLATE
241	P0490241	PHLP HD SCR M6-1 X 12
242	P0490242	EXT RETAINING RING 9MM
243	P0490243	FLAT WASHER 12MM
244	P0490244	CAPTIVE PIN
245	P0490245	HEX BOLT M8-1.25 X 50
246	P0490246	FLAT WASHER 8MM
247	P0490247	HEX NUT M8-1.25
248	P0490248	HEX NUT M10-1.5
249	P0490249	FLAT WASHER 10MM
250	P0490250	HEX BOLT M8-1.25 X 100
251	P0490251	FLAT WASHER 8MM
252	P0490252	TROLLEY WHEEL AXLE
253	P0490253	INT RETAINING RING 35MM
254	P0490254	BALL BEARING 6202-2RS
255	P0490255	TROLLEY WHEEL
256	P0490256	TROLLEY WHEEL SLEEVE
257	P0490257	TROLLEY UNIVERSAL KIT
258	P0490258	FLAT WASHER 10MM
259	P0490259	LOCK NUT M12-1.75
260	P0490260	HEX BOLT M10-1.5 X 55
261	P0490261	PEDAL BRACKET
262	P0490262	PEDAL
262A	P0490262A	PEDAL ASSEMBLY



Labels

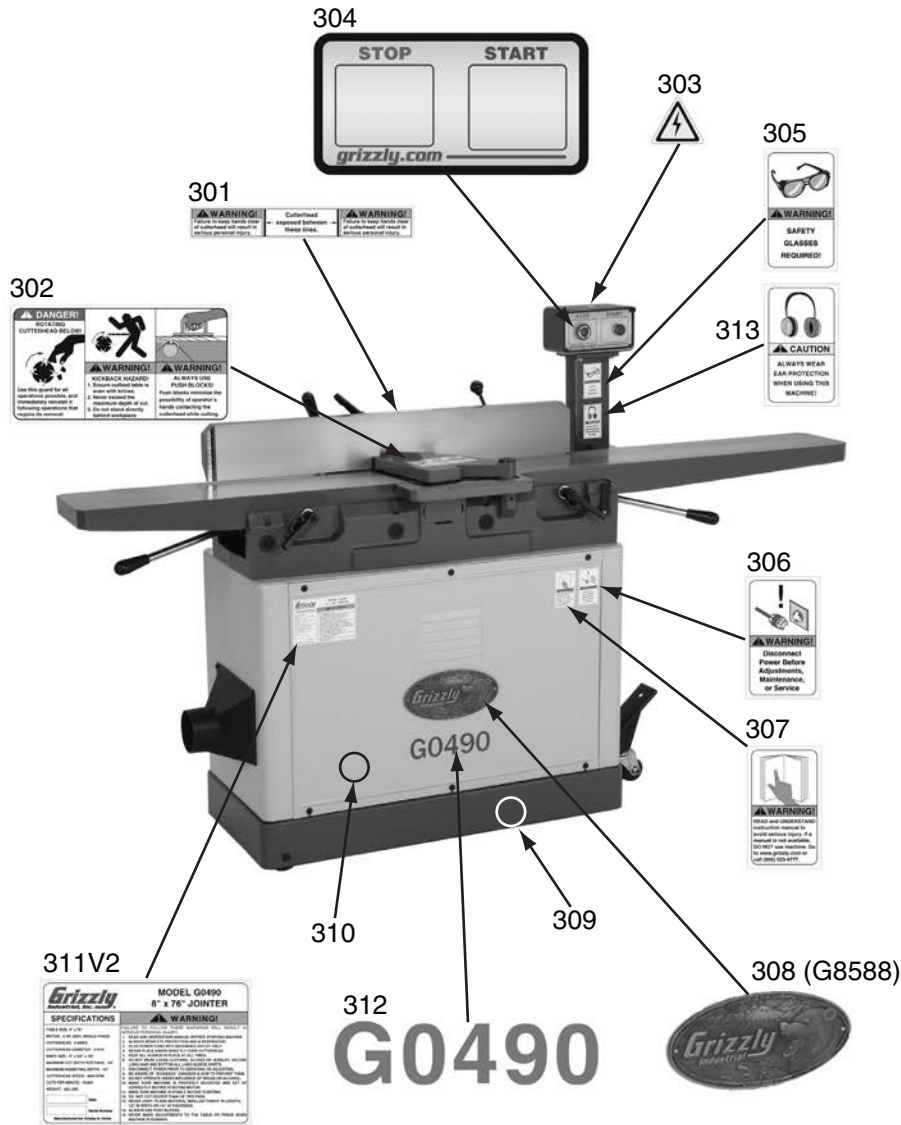

REF	PART #	DESCRIPTION
301	P0490301	FENCE/CUTTERHEAD LABEL
302	P0490302	CUTTERHEAD GUARD LABEL
303	P0490303	ELECTRICITY LABEL
304	P0490304	CONTROL PANEL FACE
305	P0490305	SAFETY GLASSES LABEL
306	P0490306	DISCONNECT POWER LABEL
307	P0490307	READ MANUAL LABEL
308	P0490308	GRIZZLY NAMEPLATE

REF	PART #	DESCRIPTION
309	P0490309	GRIZZLY GREEN TOUCH-UP PAINT
310	P0490310	GRIZZLY PUTTY TOUCH-UP PAINT
311V2	P0490311V2	MACHINE ID LABEL CSA V2.08.12 (G0490)
311V2	P0490X311V2	MACHINE ID LABEL CSA V2.08.12 (G0490X)
312	P0490312	MODEL NUMBER LABEL (G0490)
312	P0490X312	MODEL NUMBER LABEL (G0490X)
313	P0490313	HEARING PROTECTION LABEL

WARNING

Safety labels warn about machine hazards and ways to prevent injury. The owner of this machine **MUST** maintain the original location and readability of the labels on the machine. If any label is removed or becomes unreadable, **REPLACE** that label before using the machine again. Contact Grizzly at (800) 523-4777 or www.grizzly.com to order new labels.





WARRANTY CARD

Name _____
 Street _____
 City _____ State _____ Zip _____
 Phone # _____ Email _____
 Model # _____ Order # _____ Serial # _____

The following information is given on a voluntary basis. It will be used for marketing purposes to help us develop better products and services. **Of course, all information is strictly confidential.**

1. How did you learn about us?

<input type="checkbox"/> Advertisement	<input type="checkbox"/> Friend	<input type="checkbox"/> Catalog
<input type="checkbox"/> Card Deck	<input type="checkbox"/> Website	<input type="checkbox"/> Other:

2. Which of the following magazines do you subscribe to?

<input type="checkbox"/> Cabinetmaker & FDM	<input type="checkbox"/> Popular Science	<input type="checkbox"/> Wooden Boat
<input type="checkbox"/> Family Handyman	<input type="checkbox"/> Popular Woodworking	<input type="checkbox"/> Woodshop News
<input type="checkbox"/> Hand Loader	<input type="checkbox"/> Precision Shooter	<input type="checkbox"/> Woodsmith
<input type="checkbox"/> Handy	<input type="checkbox"/> Projects in Metal	<input type="checkbox"/> Woodwork
<input type="checkbox"/> Home Shop Machinist	<input type="checkbox"/> RC Modeler	<input type="checkbox"/> Woodworker West
<input type="checkbox"/> Journal of Light Cont.	<input type="checkbox"/> Rifle	<input type="checkbox"/> Woodworker's Journal
<input type="checkbox"/> Live Steam	<input type="checkbox"/> Shop Notes	<input type="checkbox"/> Other:
<input type="checkbox"/> Model Airplane News	<input type="checkbox"/> Shotgun News	
<input type="checkbox"/> Old House Journal	<input type="checkbox"/> Today's Homeowner	
<input type="checkbox"/> Popular Mechanics	<input type="checkbox"/> Wood	

3. What is your annual household income?

<input type="checkbox"/> \$20,000-\$29,000	<input type="checkbox"/> \$30,000-\$39,000	<input type="checkbox"/> \$40,000-\$49,000
<input type="checkbox"/> \$50,000-\$59,000	<input type="checkbox"/> \$60,000-\$69,000	<input type="checkbox"/> \$70,000+

4. What is your age group?

<input type="checkbox"/> 20-29	<input type="checkbox"/> 30-39	<input type="checkbox"/> 40-49
<input type="checkbox"/> 50-59	<input type="checkbox"/> 60-69	<input type="checkbox"/> 70+

5. How long have you been a woodworker/metalworker?

<input type="checkbox"/> 0-2 Years	<input type="checkbox"/> 2-8 Years	<input type="checkbox"/> 8-20 Years	<input type="checkbox"/> 20+ Years
------------------------------------	------------------------------------	-------------------------------------	------------------------------------

6. How many of your machines or tools are Grizzly?

<input type="checkbox"/> 0-2	<input type="checkbox"/> 3-5	<input type="checkbox"/> 6-9	<input type="checkbox"/> 10+
------------------------------	------------------------------	------------------------------	------------------------------

7. Do you think your machine represents a good value? Yes No

8. Would you recommend Grizzly Industrial to a friend? Yes No

9. Would you allow us to use your name as a reference for Grizzly customers in your area?
Note: We never use names more than 3 times. Yes No

10. Comments: _____

CUT ALONG DOTTED LINE

FOLD ALONG DOTTED LINE

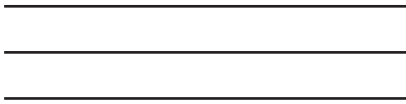

Place
Stamp
Here



GRIZZLY INDUSTRIAL, INC.
P.O. BOX 2069
BELLINGHAM, WA 98227-2069



FOLD ALONG DOTTED LINE

Send a Grizzly Catalog to a friend:

Name	_____
Street	_____
City	_____ State _____ Zip _____

TAPE ALONG EDGES--PLEASE DO NOT STAPLE

WARRANTY & RETURNS

Grizzly Industrial, Inc. warrants every product it sells for a period of **1 year** to the original purchaser from the date of purchase. This warranty does not apply to defects due directly or indirectly to misuse, abuse, negligence, accidents, repairs or alterations or lack of maintenance. This is Grizzly's sole written warranty and any and all warranties that may be implied by law, including any merchantability or fitness, for any particular purpose, are hereby limited to the duration of this written warranty. We do not warrant or represent that the merchandise complies with the provisions of any law or acts unless the manufacturer so warrants. In no event shall Grizzly's liability under this warranty exceed the purchase price paid for the product and any legal actions brought against Grizzly shall be tried in the State of Washington, County of Whatcom.

We shall in no event be liable for death, injuries to persons or property or for incidental, contingent, special, or consequential damages arising from the use of our products.

To take advantage of this warranty, contact us by mail or phone and give us all the details. We will then issue you a "Return Number," which must be clearly posted on the outside as well as the inside of the carton. We will not accept any item back without this number. Proof of purchase must accompany the merchandise.

The manufacturers reserve the right to change specifications at any time because they constantly strive to achieve better quality equipment. We make every effort to ensure that our products meet high quality and durability standards and we hope you never need to use this warranty.

Please feel free to write or call us if you have any questions about the machine or the manual.

Thank you again for your business and continued support. We hope to serve you again soon.

grizzly.com®
TOOL WEBSITE

Buy Direct and Save with Grizzly® – Trusted, Proven and a Great Value!
~Since 1983~

*Visit Our Website Today For
Current Specials!*

**ORDER
24 HOURS A DAY!
1-800-523-4777**

